



DEPARTMENT OF BIOMEDICAL ENGINEERING

III Semester- BM3301 SENSORS AND MEASUREMENTS

UNIT - 2

2.3 Inductive Transducer, LVDT

A sensor that is based on the principle of induction is known as an inductive transducer. The variable inductance transducers work, generally, upon one of the following three principles:

- (i) change of self-inductance,
- (ii) change of mutual inductance, and
- (iii) production of eddy currents,

Let us further understand the principle of induction, whenever there is a rate of change current and a conductor sees it, it produces a voltage which opposes it. In a mathematical way we can say:

$$V = L \cdot di/dt$$

Where 'L' is the inductance, 'V' is the voltage and 'di/dt' is the rate of change of current.

Further, 'L' depends on the number of turns in a coil, magnetic flux, and the area. The magnetic flux can be changed by changing the area or reluctance and thus producing a proportional output voltage.

2.3.1. Transducers working on principle of change of Self Inductance:

The self-inductance of a coil $L = N^2 / R$

where N = number of turns, and
R - reluctance of the magnetic circuit

The reluctance of the magnetic circuit, $R = \frac{l}{\mu A}$

$$L = \frac{N^2}{\frac{l}{\mu A}}$$

$$L = \frac{N^2(\mu A)}{l}$$

$$\text{Inductance, } L = N^2 \mu G$$

$$G = \text{Geometric form factor} = \frac{A}{l}$$

μ = effective permeability of the medium in and around the coil; H/m

A = area of cross-section of coil; m

and l = length of coil; m

the variation in inductance may be caused by :

- (i) change in number of turns, N,
- (ii) change in geometric configurations, G, and
- (iii) change in permeability, μ

Inductive transducers are mainly used for measurement of displacement. The displacement to be measured is arranged to cause variation of any of three variables, and thus alter the self-inductance L.

2.3.2. Transducers working on principle of change of Mutual Inductance:

An inductive transducer working on the principle variation of mutual inductance uses multiple coils. The mutual inductance between two coils is

$$M = K\sqrt{L_1 L_2}$$

where L_1 and L_2 = self-inductances of two coils,

and K = co-efficient of coupling.

Thus mutual inductance between the coils can be varied by variation of self-inductances or the co-efficient of coupling.

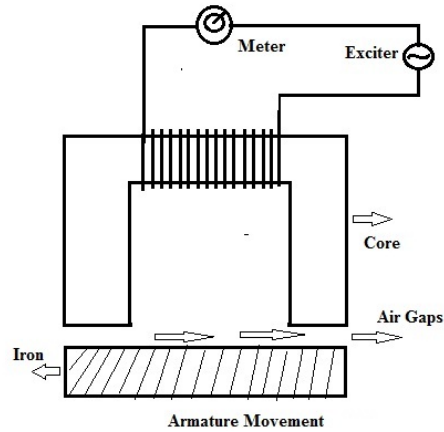

- In this type, two coils are used for mutual induction.
- One for generating excitation and another for output.
- The voltage difference between the two coils depends on the movement of the armature.
- When the armature position is changed by connecting to the movable mechanical element, then the inductance changes.
- The air gap between the armature and the magnetic material and also voltage induced in the coil depends on the change in the armature position.
- This type is also called a differential mutual inductive transducer.

2.3.3 Linear Variable Differential Transformer (LVDT) :

The most widely used inductive transducer to translate the linear motion into electrical signals is the linear variable differential transformer (LVDT). The basic construction of LVDT is shown in Figure 2

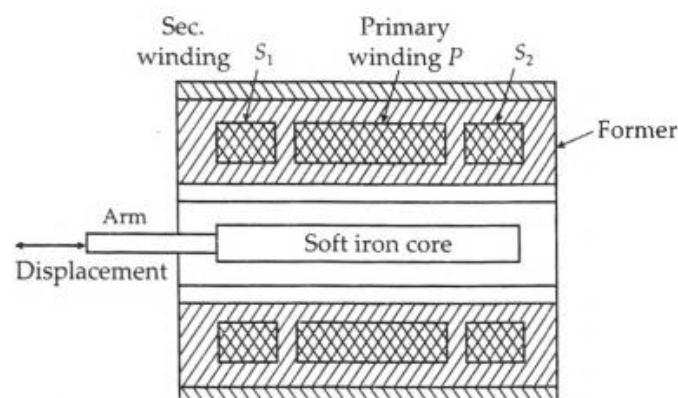

Figure 2: Linear Variable Differential Transformer (LVDT)

Construction:

- The transformer consists of a single primary winding, P and two secondary windings S₁ and S₂ wound on a cylindrical former.
- The secondary windings have equal number of turns and are identically placed on either side of the primary winding.
- The primary winding is connected to an alternating current source.
- A movable soft iron core is placed inside the former.
- The displacement to be measured is applied to the arm attached to the soft iron core.
- In practice the core is made of high permeability, nickel iron which is hydrogen annealed. This gives low harmonics, low null voltage and a high sensitivity. This is slotted longitudinally to reduce eddy current losses.
- The assembly is placed in a stainless-steel housing and the end lids provide electrostatic and electromagnetic shielding.
- The frequency of a.c. applied to primary windings may be between 50 Hz to 20 kHz

Working:

- Since the primary winding is excited by an alternating current source, it produces an alternating magnetic field which in turn induces alternating current voltages in the two secondary windings.
- The output voltage of secondary, S₁ is E_{s1} and that of secondary, S₂, is E_{s2}.
- In order to convert the outputs from S₁ and S₂ into a single voltage signal, the two secondaries and S₂ are connected in series opposition as shown in Figure 3.
- Thus, the output voltage of the transducer is the difference of the two voltages.

Differential output voltage,

$$E_0 = E_{s1} - E_{s2}$$

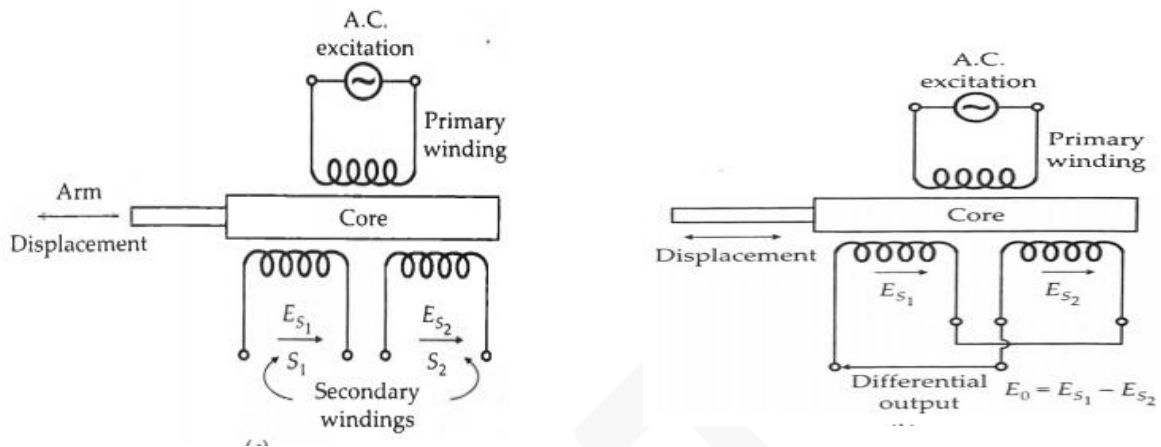

Figure 2: Circuits of an LVDT.

Case 1:- LVDT Core is in null Position:

When the core of LVDT is in null position, the flux linking between both the secondary coils are same, hence voltage induced in secondary side is also equal. Hence net output voltage is $E_0 = E_{s1} - E_{s2} = 0$

Case 2:- LVDT Core is moved left of null position:

When the core of LVDT core is moved to left, then more flux links with coil S₁ than S₂. Hence voltage induced in S₁ is greater than S₂. The net output voltage,

$$E_0 = E_{s1} - E_{s2} \text{ is positive.}$$

Case 3:- LVDT Core is moved Right of null position:

When the core of LVDT core is moved to right, then more flux links with coil S₂ than S₁. Hence voltage induced in S₂ is greater than S₁. The net output voltage is $E_0 = E_{s1} - E_{s2}$ is negative.

Output characteristics of LVDT :

- Output characteristics of LVDT is observed from the response of output voltage with respect to displacement.

- In *Figure 4* we can observe initially response is linear over a small range of displacements later it becomes non-linear.
- For zero displacement, we can also observe a small voltage. This voltage under zero displacement is called residual voltage. Magnitude of residual voltage is less than 1% of maximum voltage.

Cause of Residual Voltage in LVDT:

- Due to harmonics present in ac power supply
- Harmonics produced in iron core.
- Stray Magnetic Fields & temperature effects.

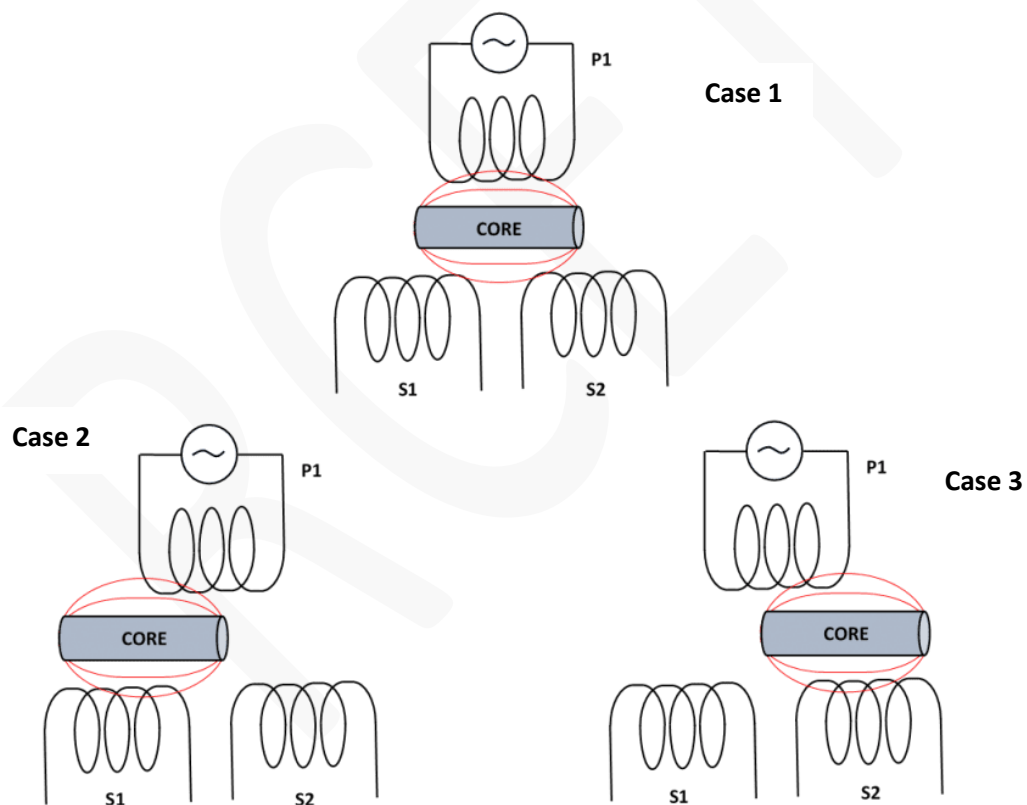

Figure 3: Different positions of core due to displacement

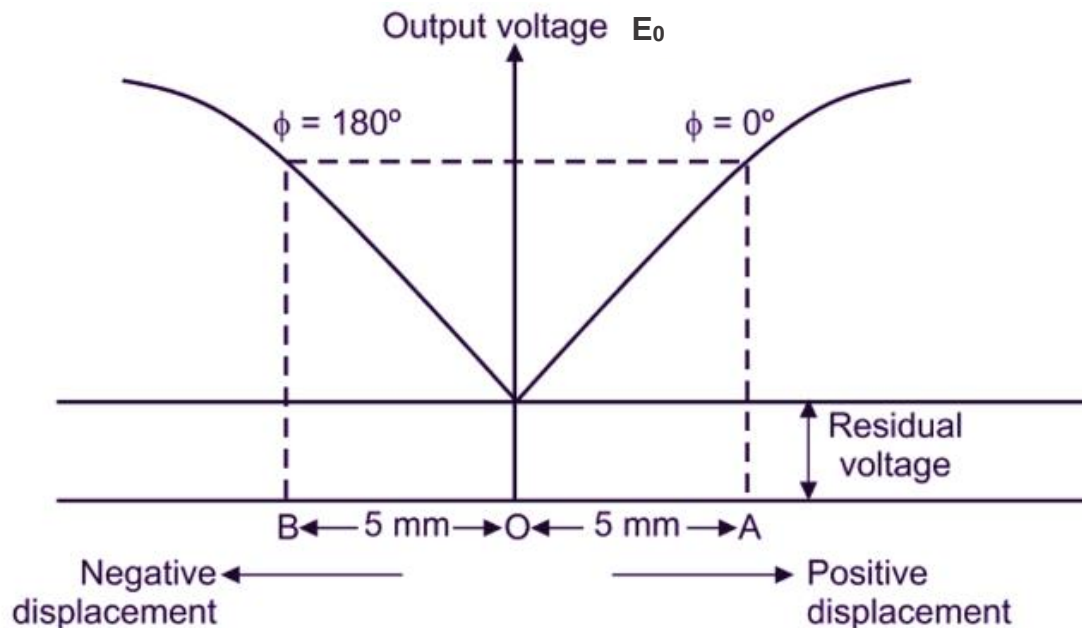

Figure 4: Variation output voltage with linear displacement for an LVDT.

2.3.4 Advantages of LVDT:

1. **High range:** The LVDTs have a very high range for measurement of displacement.
2. There is no physical contact between the movable core and coil structure which means that the LVDT is a **frictionless device**.
3. **Immunity from External Effects:** The separation between LVDT core and LVDT coils permits the isolation of media such as pressurized, corrosive, or caustic fluids from the coil assembly by a non-magnetic barrier interposed between the core and inside of the coil.
4. **High input and high sensitivity.** The LVDT gives a high output and many a times there is no need for amplification.
5. **Ruggedness:** These transducers can usually tolerate high degree of shock and vibrations especially when the core is spring loaded without any adverse effects.

6. **Low Hysteresis:** LVDTs show a low hysteresis and hence repeatability is excellent under all conditions.
7. **Low Power Consumption:** Most of LVDTs consume power which is less than 1 W.

2.3.5. Disadvantages of LVDT:

1. Sensitive to a stray magnetic field
2. It has large primary voltage produce distortion in an output
3. Temperature affects the performance
4. Vibration due to displacement can affect the performance of the LVDT device
5. Large displacement is needed for small output

2.3.6. Applications of LVDT:

1. The LVDT can be used in all applications where displacements ranging from fraction of a mm to a few cm have to be measured.
2. Acting as secondary transducer it can be used as a device to measure force, weight and pressure...
3. It is also used in Industrial Automation and aircraft. Turbine, Satellite, hydraulics, etc.
4. To control weight and thickness of medicinal products viz. tablets or pills