

HYDRAULICS AND PNEUMATICS

Chapter – 3

UNIT II HYDRAULIC ACTUATORS AND CONTROL COMPONENTS

Direction Control, pressure control valves – Types, Construction and Operation.

Direction control valve

Directional control valves are used to control the distribution of energy in a fluid power system. They provide the direction to the fluid and allow the flow in a particular direction. These valves are used to control the start, stop and change in direction of the fluid flow. These valves regulate the flow direction in the hydraulic circuit. These control valves contain ports that are external openings for the fluid to enter and leave. The number of ports is usually identified by the term 'way'. For example, a valve with four ports is named as four-way valve. The fluid flow rate is responsible for the speed of actuator (motion of the output) and should be controlled in a hydraulic system. This operation can be performed by using flow control valves. The pressure may increase gradually when the system is under operation. The pressure control valves protect the system by maintaining the system pressure within the desired range. Also, the output force is directly proportional to the pressure and hence, the pressure control valves ensure the desired force output at the actuator.

Directional control valves can be classified in the following manner:

1. Type of construction:

- Poppet valves
- Spool valves

2. Number of ports:

- Two-way valves
- Three-way valves
- Four-way valves.

3. Number of switching position:

- Two-position
- Three-position

4. Actuating mechanism:

- Manual actuation
- Mechanical actuation
- Solenoid actuation
- Hydraulic actuation
- Pneumatic actuation

- Indirect actuation

CHECK VALVES

These are unidirectional valves and permit the free flow in one direction only. These valves have two ports: one for the entry of fluid and the other for the discharge. They consist of a housing bore in which a ball or poppet is held by a small spring force. The valve having a ball as a closing member is known as a ball check valve. Various types of check valves are available for a range of applications. These valves are generally small sized, simple in construction and inexpensive. Generally, check valves are automatically operated. Human intervention or any external control system is not

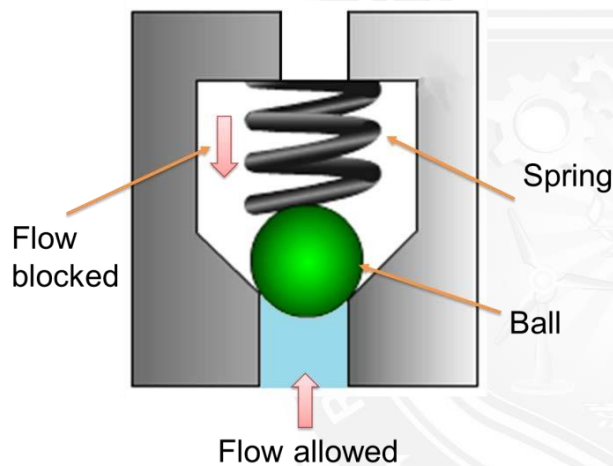

required. These valves can wear out or can generate cracks after prolonged usage and therefore they are mostly made of plastics for easy repair and replacements.

An important concept in check valves is the cracking pressure. The check valve is designed for a specific cracking pressure which is the minimum upstream pressure at which the valve operates. The simplest check valve is an inline check valve as shown in Figure. The ball is held against the valve seat by a spring force. It can be observed from the figure that the fluid flow is not possible from the spring side but the fluid from the opposite side can pass by lifting the ball against the spring force. However, there is some pressure drop across the valve due to restriction by the spring force. Therefore, these valves are not suitable for the application of high flow rate. When the operating pressure increases, the valve becomes more tightly seated in this design.

The advantages of the poppet valves include no leakage, long life and suitability with high pressure applications.

PILOT OPERATED CHECK VALVE

Another important type of check valve known as pilot operated check valve which is shown in figure. The function of the pilot operated check valve is similar to a normal check valve unless it gets an extra pressure signal through a pilot line. Pilot allows free flow in one direction and prevents the flow in another direction until the pilot pressure is applied. But when pilot pressure acts, the poppet opens and the flow is blocked from both the sides. These valves are used to stop the fluid suddenly.

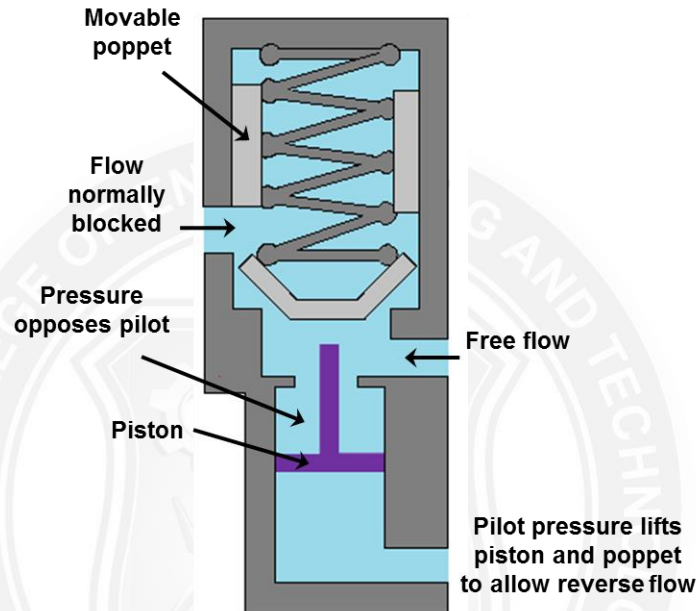

SPOOL VALVE

The spool valves derive their name from their appearance. It consists of a shaft sliding in a bore which has large groove around the circumference. This type of construction makes it look like a spool. The spool is sealed along the clearance between moving spool and housing (valve body). The quality of seal or the amount of leakage depends on the amount of clearance, viscosity of fluid and the level of the pressure. The grooves guide the fluid flow by interconnecting or blocking the holes (ports). The spool valves are categorized according to the number of operating positions and the way hydraulic lines interconnections. One of the simplest two way spool valve is shown in Figure 5.4.5. The standard terms are referred as Port 'P' is pressure port, Port 'T' is tank port and Port 'A' and Port 'B' are the actuator (or working) ports. The actuators can move in forward or backward direction depending on the connectivity of the pressure and tank port with the actuators port.

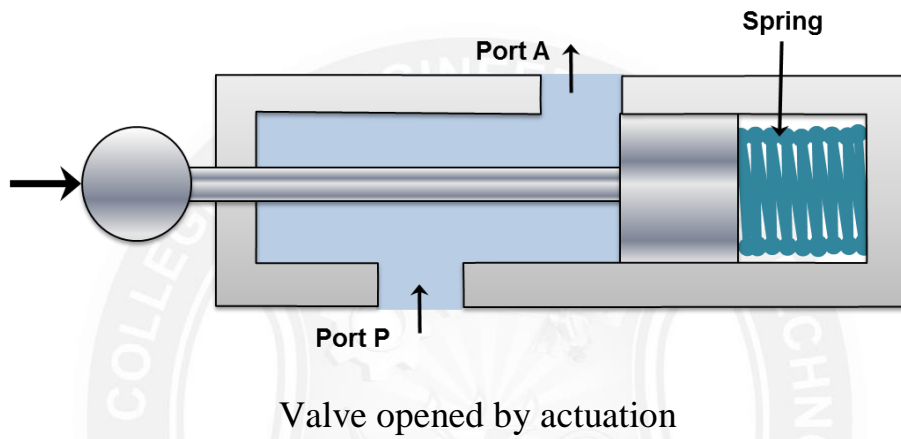
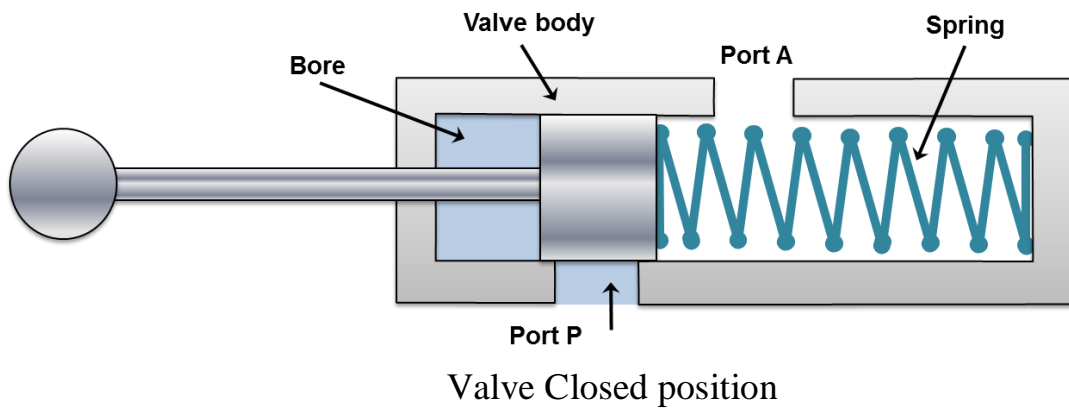

THREE WAY VALVES

When a valve has one pressure port, one tank port and one actuating port as shown in Figures. it is known as three way valve. In this valve, the pressure port pressurizes one port and exhausts another one. As shown in figures, only one actuator port is opened at a time. In some cases a neutral position is also available when both the ports are blocked. Generally, these valves are used to operate single acting cylinders.

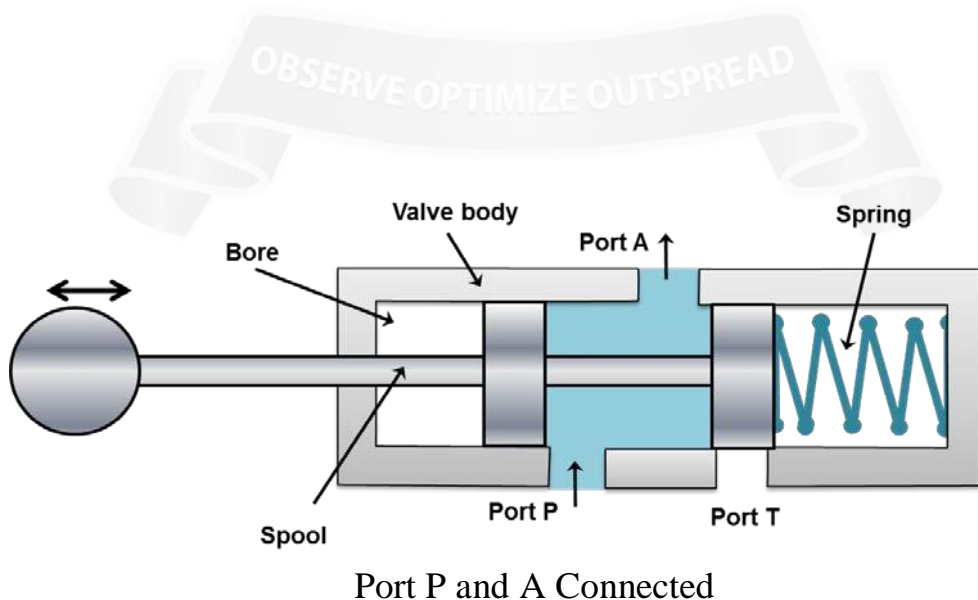

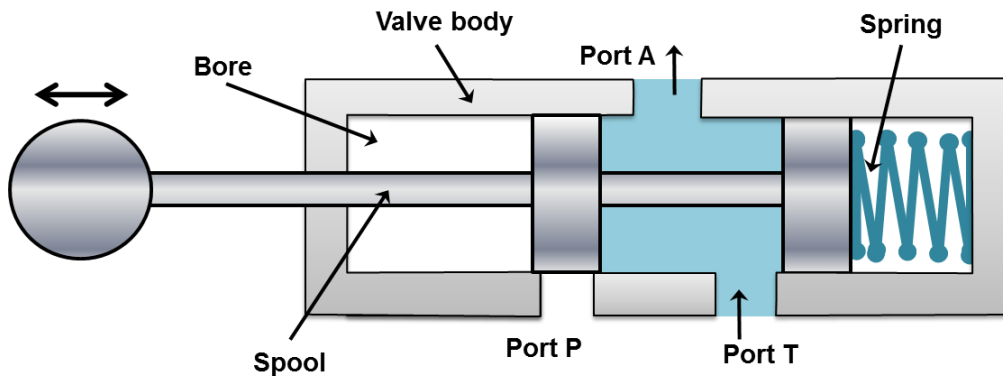

Port A and T connected

FOUR WAY VALVES

Figure shows a four-way valve. It is generally used to operate the cylinders and fluid motors in both the directions. The four ways are: pump port P, tank port T, and two working ports A and B connected to the actuator. The primary function of a four way valve is to pressurize and exhaust two working ports A and B alternatively.

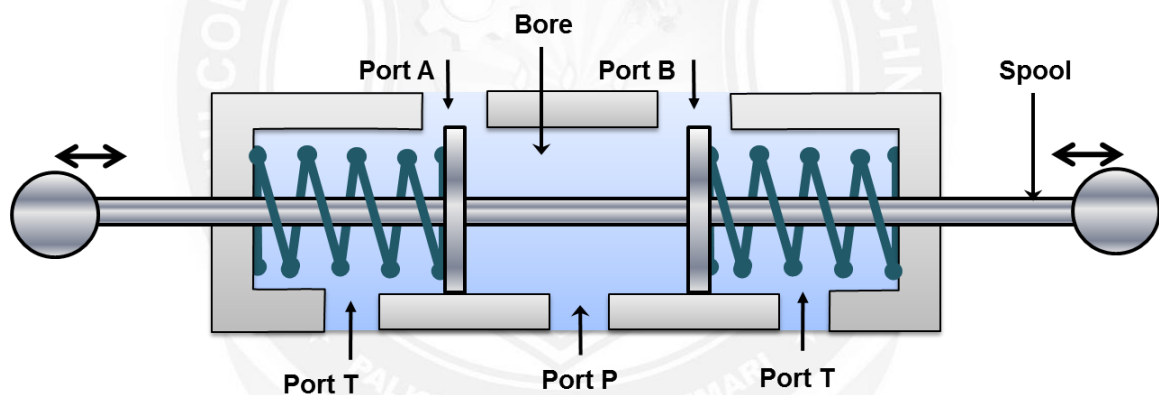

THREE POSITION FOUR WAY (3/4) VALVES

Three position four way (3/4) valves are used in double-acting cylinders to perform advance, hold and return operation to the piston. Figures 5.5.1 and 5.5.2 show three position four way valves. These types of valves have three switching positions. They have a variety of possible flow path configurations but have identical flow path configuration. When the centered path is actuated, port A and B are connected with both the ports P and T respectively. In this case, valve is not active because all the ports are open to each other. The fluid flows to the tank at atmospheric pressure. In this position work cannot be done by any part of the system. This configuration helps to prevent heat buildup.

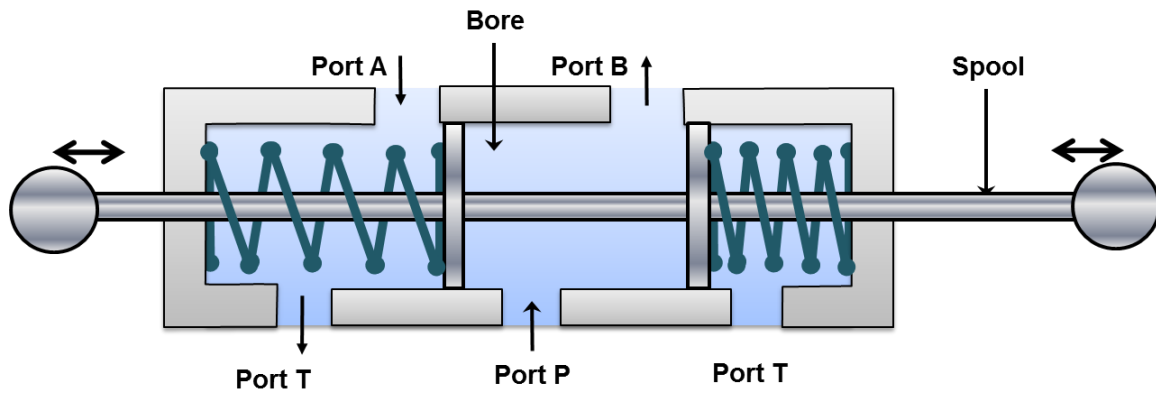

When left end (port B) is actuated, the port P is connected with ports B and T is connected with port A as shown in Figure 5.5.1. Similarly, when the right end is actuated the port P is connected to A and working port B is connected to port T as shown in Figure. The three position valves are used when the actuator is needed to stop or hold at some intermediate position. It can also be used when the multiple circuits or functions are accomplished from one hydraulic power source.

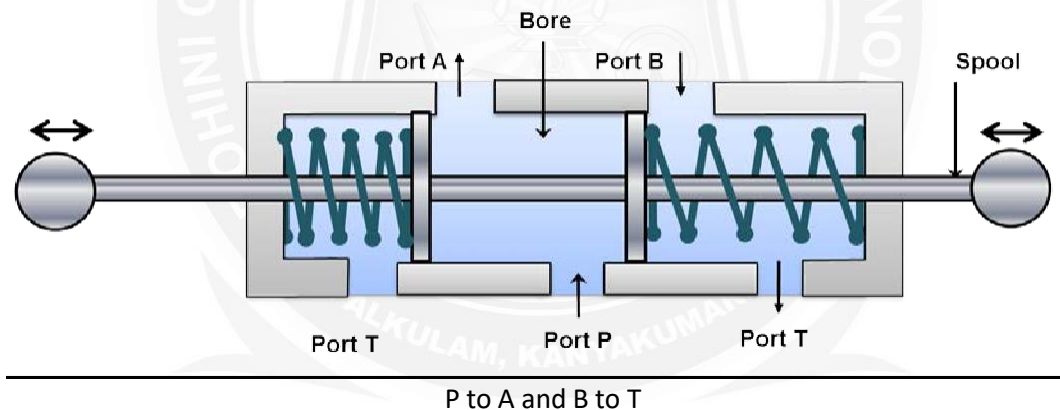

The below Figure shows a three position four way valve in the closed center position. The working of the valve is similar to open center DCV. In closed center DCV all user ports (port A and port B) are closed. Therefore, these ports are hydraulically locked and the actuator cannot be moved by the external load. The pumped fluid flows through the relief valve. The pump works under the high pressure condition which not only wastes the pump power but also causes wear of the pump parts. The fluid temperature also rises due to heat generation by the pump energy transformation. The increase in fluid temperature may lead to the oxidation and viscosity drop of the fluid. The oxidation and viscosity drop reduces the pump life and leakage in the system.

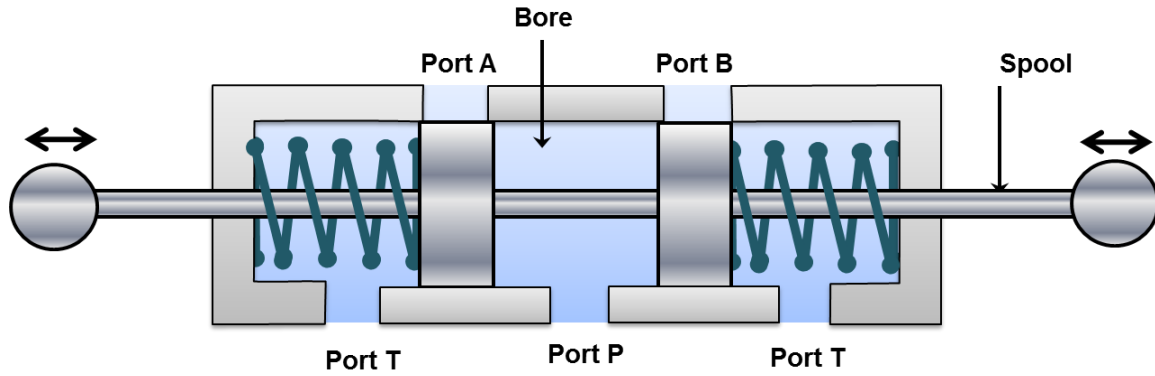

TWO POSITION FOUR WAY (2/4) VALVES

The two position four way valves have only two switching positions and do not have any mid position. Therefore, they are also known as impulse valves. The typical connections of 2/4 valves is shown in figures. These valves can be used to operate double acting cylinders. These are also used to reciprocate or hold an actuator. The operation is faster because the distance between ports of these valves is smaller. Hence, these valves are used on machines where fast reciprocation cycles are needed such as punching and stamping etc.

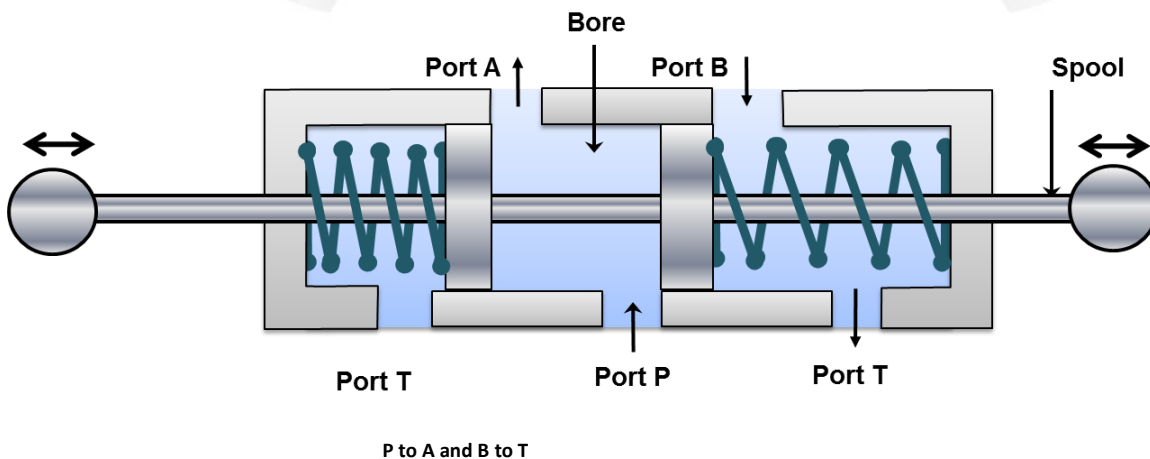
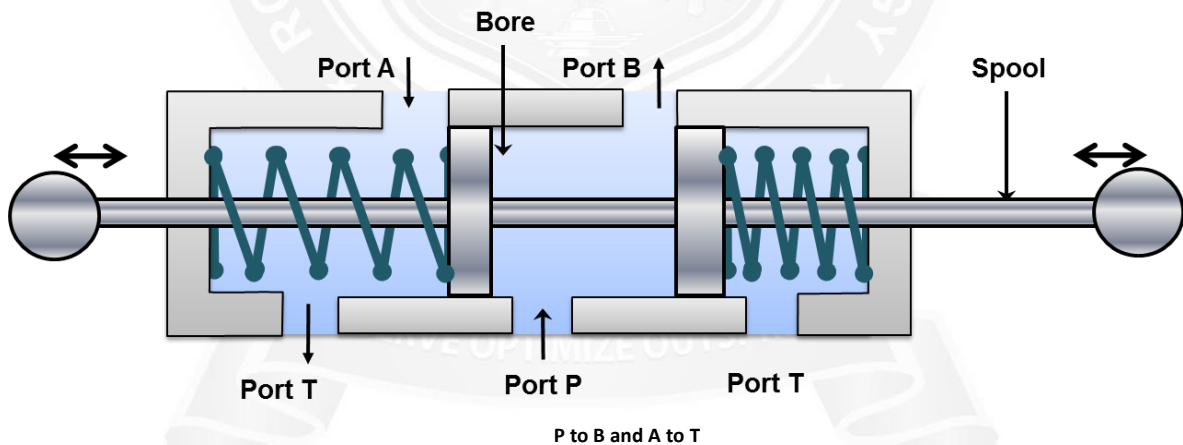

PRESSURE CONTROL VALVES:

The pressure relief valves are used to protect the hydraulic components from excessive pressure. This is one of the most important components of a hydraulic system and is essentially required for safe operation of the system. Its primary function is to limit the system pressure within a specified range. It is normally a closed type and it opens when the pressure exceeds a specified maximum value by diverting pump flow back to the tank. The simplest type valve contains a poppet held in a seat against the spring force as shown in Figure 5.6.1. The fluid enters from the opposite side of the poppet. When the system pressure exceeds the preset value, the poppet lifts and the fluid is escaped through the orifice to the storage tank directly. It reduces the system pressure and as the pressure reduces to the set limit again the valve closes. This valve does not provide a flat cut-off pressure limit with flow rate because the spring must be deflected more when the flow rate is higher. Various types of pressure control valves are discussed in the following sections:

1. Direct type of relief valve

Schematic of direct pressure relief valve is shown in figure. This type of valves has two ports; one of which is connected to the pump and another is connected to the tank. It consists of a spring chamber where poppet is placed with a spring force. Generally, the spring is adjustable to set the maximum pressure limit of the system. The poppet is held in position by combined effect of spring force and dead weight of spool. As the pressure exceeds this combined force, the poppet raises and excess fluid bypassed to the reservoir (tank). The poppet again reseats as the pressure drops below the pre-set value. A drain is also provided in the control chamber. It sends the fluid collected due to small leakage to the tank and thereby prevents the failure of the valve.

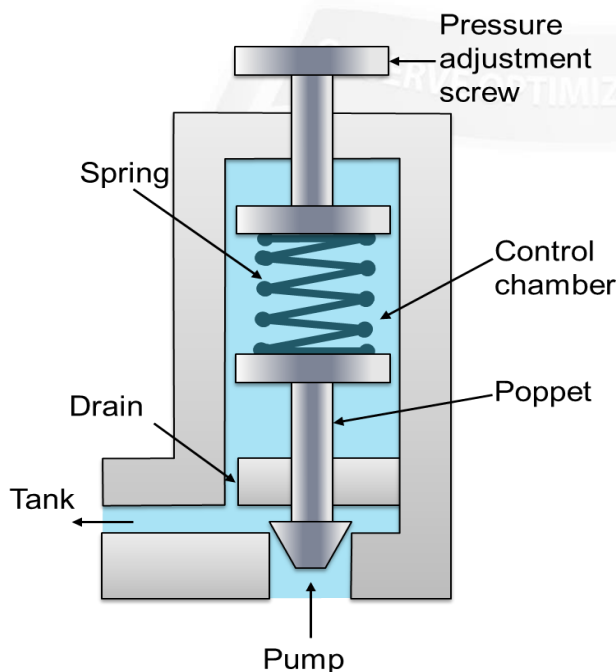

2. Unloading Valve

The construction of unloading valve is shown in Figure. This valve consists of a control chamber with an adjustable spring which pushes the spool down. The valve has two ports: one is connected to the tank and another is connected to the pump. The valve is operated by movement of the spool. Normally, the valve is closed and the tank port is also closed. These valves are used to permit a pump to operate at the minimum load. It works on the same principle as direct control valve that the pump delivery is diverted to the tank when sufficient pilot pressure is applied to move the spool. The pilot pressure maintains a static pressure to hold the valve opened. The pilot pressure holds the valve until the pump delivery is needed in the system. As the pressure is needed in the hydraulic circuit; the pilot pressure is relaxed and the spool moves down due to the self-weight and the spring force. Now, the flow is diverted to the hydraulic circuit. The drain is provided to remove the leaked oil collected in the control chamber to prevent the valve failure. The unloading valve reduces the heat buildup due to fluid discharge at a preset pressure value.

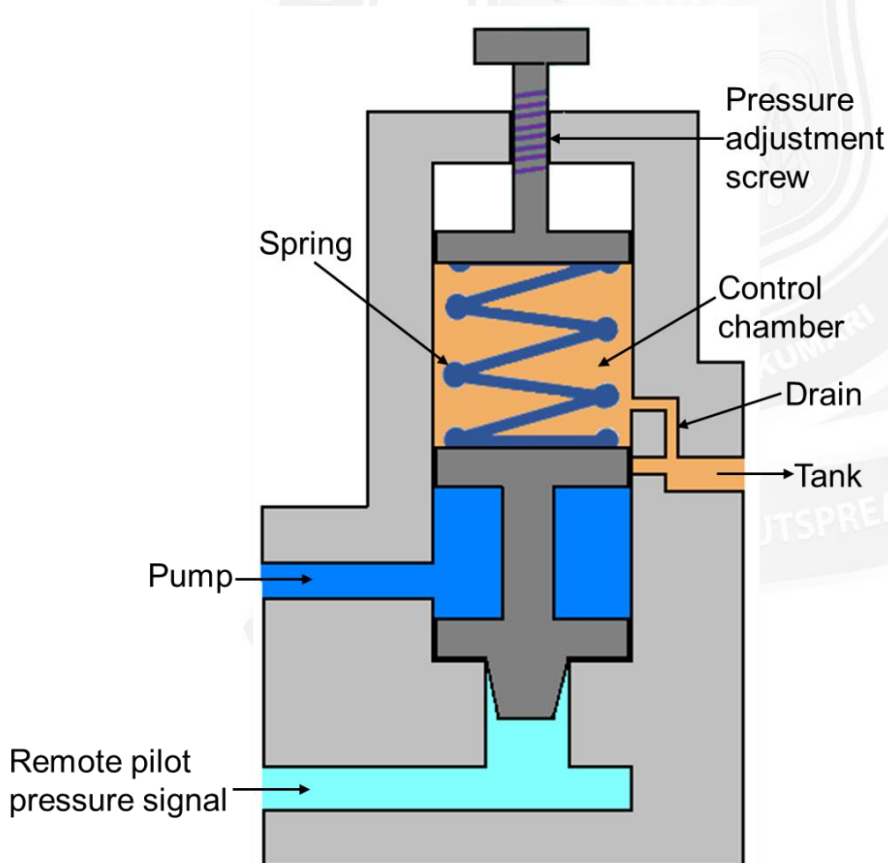

3. Sequence valve

The primary function of this type of valve is to divert flow in a predetermined sequence. It is used to operate the cycle of a machine automatically. A sequence valve may be of direct-pilot or remote-pilot operated type.

Schematic of the sequence valve is shown in Figure. Its construction is similar to the direct relief valve. It consists of the two ports; one main port connecting the main pressure line and another port (secondary port) is connected to the secondary circuit. The secondary port is usually closed by the spool. The pressure on the spool works against the spring force. When the pressure exceeds the preset value of the spring; the spool lifts and the fluid flows from the primary port to the secondary port. For remote operation; the passage used for the direct operation is closed and a separate pressure source for the spool operation is provided in the remote operation mode.

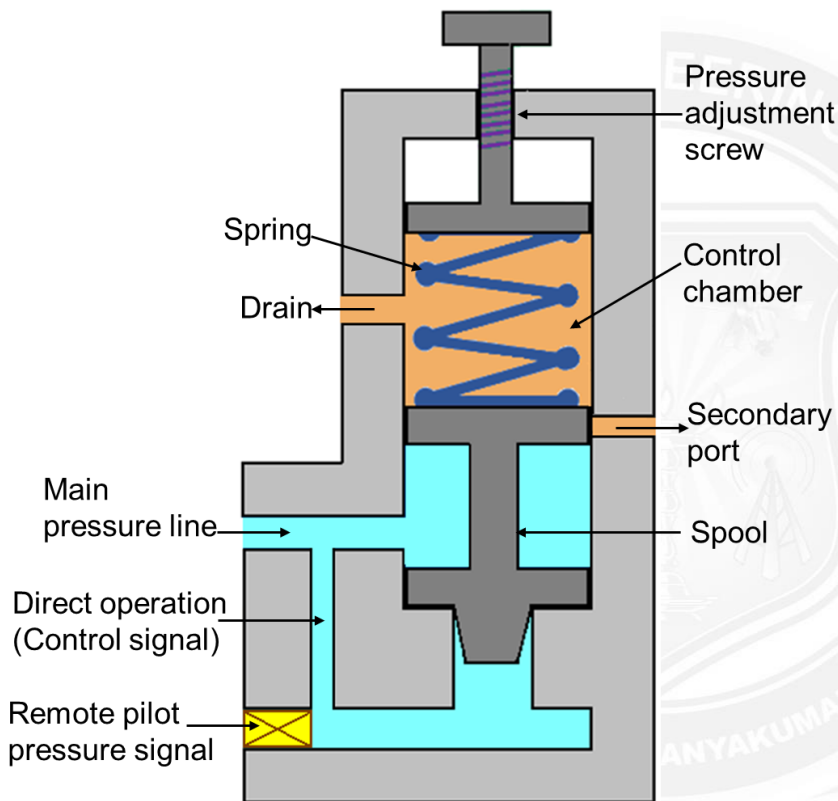

4. Counterbalance Valve

It is used to maintain the back pressure and to prevent a load from failing. The counterbalance valves can be used as breaking valves for decelerating heavy loads. These valves are used in vertical presses, lift trucks, loaders and other machine tools where position or hold suspended loads are important. Counterbalance valves work on the principle that the fluid is trapped under pressure until pilot pressure overcomes the pre-set value of spring force. Fluid is then allowed to escape, letting the load to descend under control. This valve is normally closed until it is acted upon by a remote pilot pressure source. Therefore, a lower spring force is sufficient. It leads to the valve operation at the lower pilot pressure and hence the power consumption reduces, pump life increases and the fluid temperature decreases.

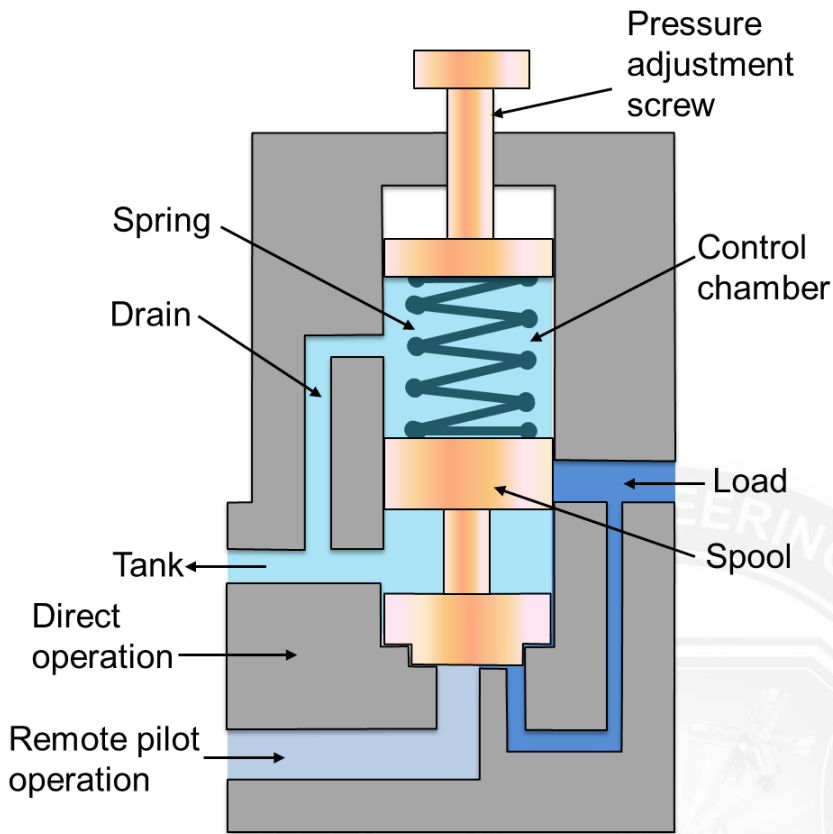

5. Pressure Reducing Valve

Sometimes a part of the system may need a lower pressure. This can be made possible by using pressure reducing valve as shown in Figure. These valves are used to limit the outlet pressure. Generally, they are used for the operation of branch circuits where the pressure may vary from the main hydraulic pressure lines. These are open type valve and have a spring chamber with an adjustable spring, a movable spool as shown in figure. A drain is provided to return the leaked fluid in the spring (control) chamber. A free flow passage is provided from inlet port to the outlet port until a signal from the outlet port tends to throttle the passage through the valve. The pilot pressure opposes the spring force and when both are balanced, the downstream is controlled at the pressure setting. When the pressure in the reduced pressure line exceeds the valve setting, the spool moves to reduce the flow passage area by compressing the spring. It can be seen from the figure that if the spring force is more, the valve opens wider and if the controlled pressure has greater force, the valves moves towards the spring and throttles the flow.

