

5.2 RF AMPLIFIERS:

CHARACTERISTICS OF AMPLIFIERS:

The most important and complex task is the amplification of an input signal through either a single or multistage transistor circuit. A generic single-stage amplifier configuration embedded between input and output matching networks, as shown in Fig 5.2.1.

Input and Output matching networks, are needed to reduce undesired reflections and thus improve the power flow capabilities. Interm of performance specifications, the following list constitutes a set of key amplifier parameters.

- Gain and gain flatness
- Operating frequency and bandwidth
- Output power
- Power supply requirements
- Input and output power reflections
- Noise figure Γ_S

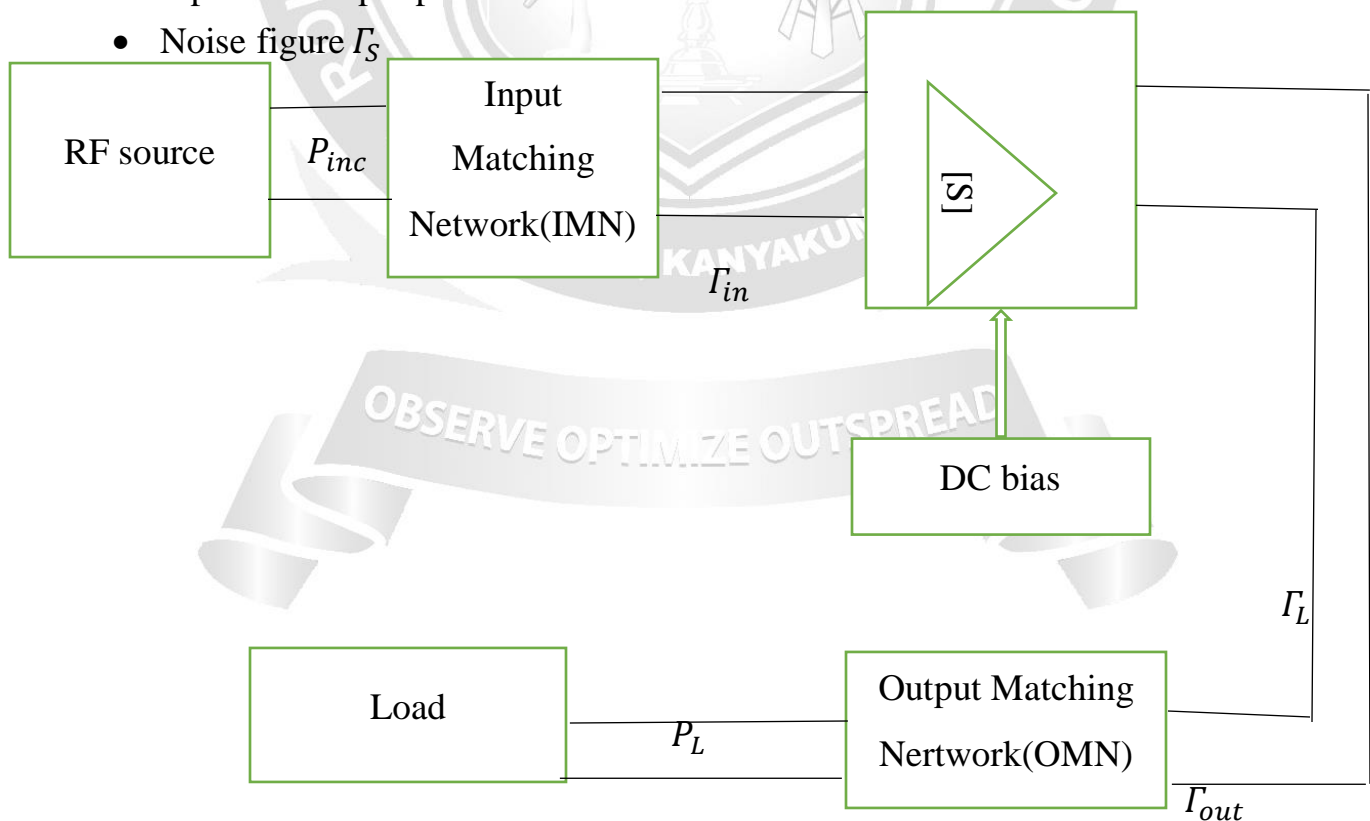

Fig: 5.2.1 Generic amplifier system

- i. Reflection Coefficient seen looking toward the load

$$\Gamma_L = \frac{Z_L - Z_0}{Z_L + Z_0}$$

- ii. Reflection Coefficient seen looking toward the source

$$\Gamma_S = \frac{Z_S - Z_0}{Z_S + Z_0}$$

- iii. Input reflection Coefficient

$$\Gamma_{in} = S_{11} + \frac{S_{12} S_{21} \Gamma_L}{1 - S_{22} \Gamma_L}$$

- iv. Output reflection Coefficient

$$\Gamma_{out} = S_{22} + \frac{S_{12} S_{21} \Gamma_S}{1 - S_{11} \Gamma_S}$$

From signal flow graph In figure,

$$b_s + a_1' \Gamma_S = b_1'$$

$$b_s = b_1' - a_1' \Gamma_S$$

$$b_s = b_1' \left[1 - \frac{a_1'}{b_1'} \Gamma_S \right]$$

$$b_s = b_1' \left[1 - \frac{b_1}{a_1} \Gamma_S \right]$$

$$b_s = b_1' [1 - \Gamma_{in} \Gamma_S] \quad \dots\dots(1)$$

$$b_1' = \frac{b_s}{1 - \Gamma_{in} \Gamma_S} \quad \dots\dots(2)$$

Incident power wave (P_{inc}) associated with b_1' is given as,

$$P_{inc} = \frac{|b_1'|^2}{2}$$

$$P_{inc} = \frac{1}{2} \frac{|b_s|^2}{|1 - \Gamma_{in} \Gamma_S|^2} \quad \dots\dots(3)$$

which is the power launched towards the amplifier,

$$\Gamma_{in} = 0 \text{ \& } \Gamma_S \neq 0$$

$$P_{inc} = \frac{|b_s|^2}{2} \quad \dots\dots(4)$$

The actual input power P_{in} is observed at the input terminal of the amplifier is composed of the incident & reflected power waves.

$$P_{in} = P_{inc} (1 - |\Gamma_{in}|^2)$$

$$P_{in} = \frac{1}{2} \frac{|b_s|^2}{|1 - \Gamma_{in} \Gamma_S|^2} (1 - |\Gamma_{in}|^2) \quad \dots(5)$$

Maximum power transfer from the source to the amplifier is achieved if the input impedance is complex conjugate matched ($Z_{in} = Z_v$) or, in terms of the reflection coefficients if $\Gamma_{in} = \Gamma_S^*$

Under maximum power transfer condition, the available power P_A as,

$$P_A = P_{in} |_{\Gamma_{in} = \Gamma_S^*}$$

$$P_A = \frac{1}{2} \frac{|b_s|^2}{|1 - \Gamma_{in} \Gamma_S|^2} (1 - |\Gamma_{in}|^2) \Big|_{\Gamma_{in} = \Gamma_S^*}$$

$$P_A = \frac{1}{2} \frac{|b_s|^2}{|1 - |\Gamma_S|^2|^2} (1 - |\Gamma_S|^2)$$

$$P_A = \frac{1}{2} \frac{|b_s|^2}{(1 - |\Gamma_S|^2)} \quad \dots(6)$$

Power delivered to the load is given by,

$$P_L = \frac{1}{2} |b_2|^2 (1 - |\Gamma_L|^2) \quad \dots(7)$$

TRANSDUCER POWER GAIN

$$G_T = \frac{\text{power delivered to the load}}{\text{available power from the source}} \quad \dots (1)$$

$$G_T = \frac{P_L}{P_{av(s)}} = \frac{P_L}{P_A} \quad \dots(2)$$

$$P_L = \frac{1}{2} |b_2|^2 (1 - |\Gamma_L|^2) \quad \dots(3)$$

$$P_A = \frac{|b_s|^2}{(1 - |\Gamma_S|^2)} \quad \dots(4)$$

Sub equ (3) and (4) in equ (2),

$$G_T = \frac{\frac{1}{2} |b_2|^2 (1 - |\Gamma_L|^2)}{\frac{|b_s|^2}{(1 - |\Gamma_S|^2)}}$$

$$G_T = \left| \frac{b_2}{b_s} \right|^2 (1 - |\Gamma_L|^2) (1 - |\Gamma_S|^2) \quad \dots\dots(5)$$

The reflected wave at port 2 is b_2 ,

$$b_2 = \frac{a_1 S_{21}}{1 - S_{22} \Gamma_L} \quad \dots\dots(6)$$

By rearranging the above equation (6),

$$b_2(1 - S_{22} \Gamma_L) = a_1 S_{21}$$

$$a_1 = \frac{b_2(1 - S_{22} \Gamma_L)}{S_{21}} \quad \dots\dots(7)$$

The source reflection coefficient b_s is given by,

$$b_s = (1 - \Gamma_S \Gamma_{in}) a_1 \quad \dots\dots(8)$$

The input reflection coefficient Γ_{in} is given by,

$$\Gamma_{in} = S_{11} + \frac{S_{12} S_{21} \Gamma_L}{1 - S_{22} \Gamma_L} \quad \dots\dots(9)$$

By rearranging the equ (11) by,

$$\Gamma_{in} = \frac{S_{11} (1 - S_{22} \Gamma_L) + S_{12} S_{21} \Gamma_L}{1 - S_{22} \Gamma_L}$$

To find 1- $\Gamma_S \Gamma_{in}$:

$$\Gamma_S \Gamma_{in} = \frac{S_{11} (1 - S_{22} \Gamma_L) \Gamma_S + S_{12} S_{21} \Gamma_L \Gamma_S}{1 - S_{22} \Gamma_L}$$

$$1 - \Gamma_S \Gamma_{in} = 1 - \frac{S_{11} (1 - S_{22} \Gamma_L) \Gamma_S + S_{12} S_{21} \Gamma_L \Gamma_S}{1 - S_{22} \Gamma_L}$$

$$= 1 - \frac{S_{11} \Gamma_S - S_{11} S_{22} \Gamma_L \Gamma_S + S_{12} S_{21} \Gamma_L \Gamma_S}{1 - S_{22} \Gamma_L}$$

$$= \frac{(1 - S_{22} \Gamma_L) - S_{11} \Gamma_S - S_{11} S_{22} \Gamma_L \Gamma_S - S_{12} S_{21} \Gamma_L \Gamma_S}{1 - S_{22} \Gamma_L}$$

$$= \frac{(1 - S_{22} \Gamma_L) - S_{11} \Gamma_S (1 - S_{22} \Gamma_L) - S_{12} S_{21} \Gamma_L \Gamma_S}{1 - S_{22} \Gamma_L}$$

$$= \frac{(1 - S_{22} \Gamma_L)(1 - S_{11} \Gamma_S) - S_{12} S_{21} \Gamma_L \Gamma_S}{1 - S_{22} \Gamma_L} \quad \dots\dots(12)$$

To find b_s :

Sub equ (12) in equ (8),

From equ (8),

$$b_s = (1 - \Gamma_S \Gamma_{in}) a_1$$

$$b_s = \left[\frac{(1 - S_{22} \Gamma_L)(1 - S_{11} \Gamma_S) - S_{12} S_{21} \Gamma_L \Gamma_S}{1 - S_{22} \Gamma_L} \right] a_1 \dots (13)$$

Sub equ (7) in equ (13),

$$b_s = \left[\frac{(1 - S_{22} \Gamma_L)(1 - S_{11} \Gamma_S) - S_{12} S_{21} \Gamma_L \Gamma_S}{1 - S_{22} \Gamma_L} \right] \times \frac{b_2(1 - S_{22} \Gamma_L)}{S_{21}}$$

$$\frac{b_s}{b_2} = \frac{(1 - S_{22} \Gamma_L)(1 - S_{11} \Gamma_S) - S_{12} S_{21} \Gamma_L \Gamma_S}{S_{21}} \dots (14)$$

To find $\left| \frac{b_s}{b_2} \right|^2$:

$$\left| \frac{b_s}{b_2} \right|^2 = \frac{|S_{21}|^2}{|(1 - S_{22} \Gamma_L)(1 - S_{11} \Gamma_S) - S_{12} S_{21} \Gamma_L \Gamma_S|^2} \dots (15)$$

To find G_T ,

From equ (5),

$$G_T = \left| \frac{b_2}{b_s} \right|^2 (1 - |\Gamma_L|^2) (1 - |\Gamma_S|^2)$$

$$G_T = \frac{|S_{21}|^2 (1 - |\Gamma_L|^2) (1 - |\Gamma_S|^2)}{|(1 - S_{22} \Gamma_L)(1 - S_{11} \Gamma_S) - S_{12} S_{21} \Gamma_L \Gamma_S|^2}$$

$$G_T = \frac{|S_{21}|^2 (1 - |\Gamma_L|^2) (1 - |\Gamma_S|^2)}{|1 - S_{22} \Gamma_L|^2 |1 - \Gamma_S \Gamma_{in}|^2}$$

Problem 1:

An amplifier has the following S-parameters : $S_{11}=0.3 \angle -70^\circ$, $S_{12}=0.2 \angle -10^\circ$, $S_{21}=3.5 \angle 85^\circ$ and $S_{22}=0.4 \angle -45^\circ$. Furthermore, input side of the amplifier is connected to a voltage source with $V_S = 5V \angle 0^\circ$ and the source impedance $Z_S = 40\Omega$. The output is utilized to drive the antenna which has an impedance of $Z_L = 73\Omega$. Assuming that the S-parameters of the amplifier are measured with reference to a $Z_0 = 50\Omega$ characteristic impedance, Calculate

- a) transducer gain, unilateral transducer gain, available gain, operating power gain.
- b) Power delivered to the load , available power and incident power to the amplifier.

Given data:

$$S_{11} = 0.3 \angle -70^\circ$$

$$S_{12} = 0.2 \angle -10^\circ$$

$$S_{21} = 3.5 \angle 85^\circ$$

$$S_{22} = 0.4 \angle -45^\circ$$

$$Z_S = 40 \text{ ohm}$$

$$Z_L = 73 \text{ ohm}$$

$$Z_O = 50 \text{ ohm}$$

$$V_S = 5 \text{ V} \angle 0^\circ$$

$$\Gamma_L = \frac{Z_L - Z_O}{Z_L + Z_O}$$

$$\Gamma_L = \frac{73 - 50}{73 + 50}$$

$$\Gamma_L = 0.187$$

$$\Gamma_S = \frac{Z_S - Z_O}{Z_S + Z_O}$$

$$\Gamma_S = \frac{40 - 50}{40 + 50}$$

$$\Gamma_S = -0.111$$

$$b_s = \frac{\sqrt{Z_O}}{Z_S + Z_O} V_S$$

$$b_s = \frac{\sqrt{50}}{40 + 50} 5$$

$$b_s = 0.392$$

$$\Gamma_{in} = S_{11} + \frac{S_{12} S_{21} \Gamma_L}{1 - S_{22} \Gamma_L}$$

$$\Gamma_{in} = 0.3 \angle -70 + \frac{(0.2 \angle -10)(3.5 \angle 85)(0.187)}{1 - (0.4 \angle -45)(0.187)}$$

$$\Gamma_{in} = 0.3 \angle -70 + \frac{(0.7 \angle 75)(0.187)}{1 - (0.0748 \angle -45)}$$

$$\Gamma_{in} = 0.3 \angle -70 + \frac{(0.1309 \angle 75)}{1 - (0.0748 \angle -45)}$$

$$\Gamma_{in} = 0.3 \angle -70 + 0.138 \angle 71.81$$

$$\Gamma_{in} = 0.209 \angle -45.98$$

$$\Gamma_{out} = S_{22} + \frac{S_{12} S_{21} \Gamma_S}{1 - S_{11} \Gamma_S}$$

$$\Gamma_{out} = 0.4 \angle -45 + \frac{(0.2 \angle -10)(3.5 \angle 85)(-0.111)}{1 - (0.3 \angle -70)(-0.111)}$$

$$\Gamma_{out} = 0.4 \angle -45 + \frac{(0.7 \angle 75)(-0.111)}{1 - 0.333 \angle -70}$$

$$\Gamma_{out} = 0.4 \angle -45 + \frac{(0.0777 \angle 75)}{1 - 0.333 \angle -70}$$

$$\Gamma_{out} = 0.4 \angle -45 + 0.0767 \angle 76.77$$

$$\Gamma_{out} = 0.445 \angle -53.42$$

a) Transducer gain, unilateral transducer gain, available gain, operating power gain.

$$G_T = \frac{|S_{21}|^2 (1 - |\Gamma_L|^2) (1 - |\Gamma_S|^2)}{|1 - S_{11} \Gamma_S|^2 |1 - \Gamma_{out} \Gamma_L|^2}$$

$$G_T = \frac{(3.5)^2 (1 - (0.187)^2) (1 - (-0.111)^2)}{|1 - (0.187)(0.445 \angle -53.42)|^2 |1 - (0.3 \angle -70)(-0.111)|^2}$$

$$G_T = 12.556$$

$$G_T(\text{dB}) = 10 \log_{10} (G_T)$$

$$G_T(\text{dB}) = 10 \log_{10} (12.556)$$

$$G_T(\text{dB}) = 10.988 \text{ dB}$$

$$G_{TU} = \frac{|S_{21}|^2 (1 - |\Gamma_L|^2) (1 - |\Gamma_S|^2)}{|1 - S_{22} \Gamma_L|^2 |1 - S_{11} \Gamma_S|^2}$$

$$G_{TU} = 12.68$$

$$G_{TU}(\text{dB}) = 10 \log_{10} (G_{TU})$$

$$G_{TU}(\text{dB}) = 10 \log_{10} (12.68)$$

$$G_{TU}(\text{dB}) = 11.03 \text{ Db}$$

$$G_A = \frac{|S_{21}|^2 (1 - |\Gamma_s|^2)}{|1 - S_{11} \Gamma_s|^2 (1 - |\Gamma_{out}|^2)}$$

$$G_A = 14.74$$

$$G_A(\text{dB}) = 10 \log_{10} (G_A)$$

$$G_A(\text{dB}) = 10 \log_{10} (14.74)$$

$$G_A(\text{dB}) = 11.68 \text{ dB}$$

$$G = \frac{|S_{21}|^2 (1 - |\Gamma_L|^2)}{(1 - |\Gamma_{in}|^2) |1 - S_{22} \Gamma_L|^2}$$

$$G = 13.75$$

$$G(\text{dB}) = 10 \log_{10} (G)$$

$$G(\text{dB}) = 10 \log_{10} (13.75)$$

$$G(\text{dB}) = 11.38 \text{ dB}$$

b) Power delivered to the load , available power and incident power to the amplifier.

$$P_{inc} = \frac{1}{2} \frac{|b_s|^2}{|1 - \Gamma_{in} \Gamma_s|^2}$$

$$P_{inc} = 0.0733 \text{ W}$$

$$P_{inc} (\text{dBm}) = 10 \log_{10} \left(\frac{P_{inc} (\text{watts})}{1 \text{ mW}} \right)$$

$$P_{inc} (\text{dBm}) = 10 \log_{10} \left(\frac{0.0733}{1 \times 10^{-3}} \right)$$

$$P_{inc} (\text{dBm}) = 18.65 \text{ dBm}$$

$$P_A = \frac{1}{2} \frac{|b_s|^2}{(1 - |\Gamma_s|^2)}$$

$$P_A = \frac{1}{2} \frac{(0.392)^2}{(1 - (-0.111)^2)}$$

$$P_A = 0.0778 \text{ W}$$

$$P_A \text{ (dBm)} = 10 \log_{10} \left(\frac{P_A \text{ (watts)}}{1\text{mW}} \right)$$

$$P_A \text{ (dBm)} = 18.909 \text{ dBm}$$

$$G_T = \frac{P_L}{P_A}$$

$$P_L = P_A G_T$$

$$P_L = 0.976 \text{ W}$$

$$P_L \text{ (dBm)} = 10 \log_{10} \left(\frac{P_L \text{ (watts)}}{1\text{mW}} \right)$$

$$P_L \text{ (dBm)} = 29.89 \text{ dBm}$$

