

# Delta Modulation

The sampling rate of a signal should be higher than the Nyquist rate, to achieve better sampling. If this sampling interval in Differential PCM is reduced considerably, the sample-to-sample amplitude difference is very small, as if the difference is 1-bit quantization, then the step-size will be very small i.e.,  $\Delta$

The type of modulation, where the sampling rate is much higher and in which the stepsize after quantization is of a smaller value  $\Delta$ , such a modulation is termed as delta modulation.

## Features of Delta Modulation

Following are some of the features of delta modulation.

- An over-sampled input is taken to make full use of the signal correlation.
- The quantization design is simple.
- The input sequence is much higher than the Nyquist rate.
- The quality is moderate.
- The design of the modulator and the demodulator is simple.
- The stair-case approximation of output waveform.
- The step-size is very small, i.e.,  $\Delta$  delt
- The bit rate can be decided by the user.
- This involves simpler implementation.

Delta Modulation is a simplified form of DPCM technique, also viewed as 1-bit DPCM scheme. As the sampling interval is reduced, the signal correlation will be higher.

## Delta Modulator

The Delta Modulator comprises of a 1-bit quantizer and a delay circuit along with two summer circuits. Following is the block diagram of a delta modulator.

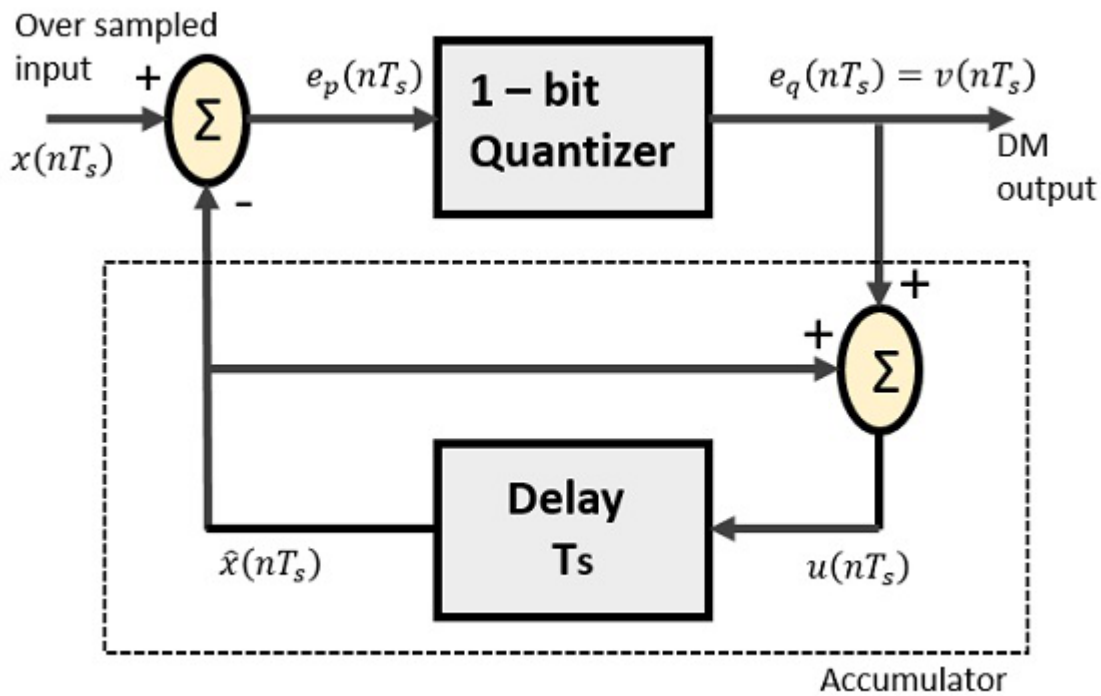

### Differential Pulse Code Modulation (DPCM)

For the signals which does not change rapidly from one sample to next sample, the PCM scheme is not preferred. When such highly correlated samples are encoded the resulting encoded signal contains redundant information. By removing this redundancy before encoding an efficient coded signal can be obtained. One of such scheme is the DPCM technique. By knowing the past behaviour of a signal up to a certain point in time, it is possible to make some inference about the future values. Transmitter: Let  $x(t)$  be the signal to be sampled and  $x(nT_s)$  be its samples. In this scheme the input to the quantizer is a signal. where  $\hat{x}(nT_s)$  is the prediction for un quantized sample  $x(nT_s)$ . This predicted value is produced by using a predictor whose input, consists of a quantized versions of the input signal  $x(nT_s)$ . The signal  $e(nT_s)$  is called the prediction error.

By encoding the quantizer output, in this method, we obtain a modified version of the PCM called differential pulse code modulation (DPCM).

Quantizer output,

$$v(nT_s) = Q[e(nT_s)] = e(nT_s) + q(nT_s)$$

Predictor input is the sum of quantizer output and predictor output,

$$u(nT_s) = \hat{x}(nT_s) + v(nT_s)$$

$$u(nT_s) = \hat{x}(nT_s) + e(nT_s) + q(nT_s)$$

$$u(nT_s) = x(nT_s) + q(nT_s)$$

The receiver consists of a decoder to reconstruct the quantized error signal. The quantized version of the original input is reconstructed from the decoder output using the same predictor as used in the transmitter. In the absence of noise the encoded signal at the receiver input is identical to the encoded signal at the transmitter output. Correspondingly the receive output is equal to  $u(nT_s)$ , which differs from the input  $x(nT_s)$  only by the quantizing error  $q(nT_s)$ .

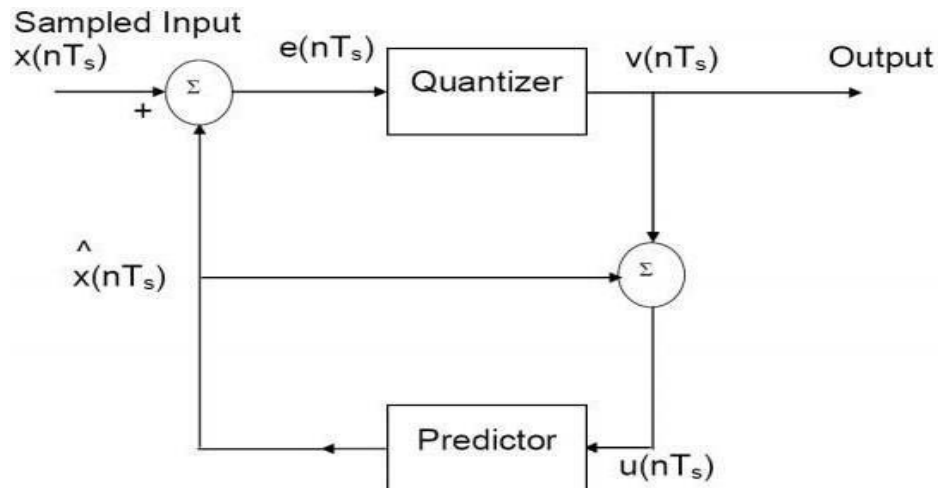

Fig 2.2.1: Block Diagram of DPCM Transmitter  
(Source: Electronics Post)

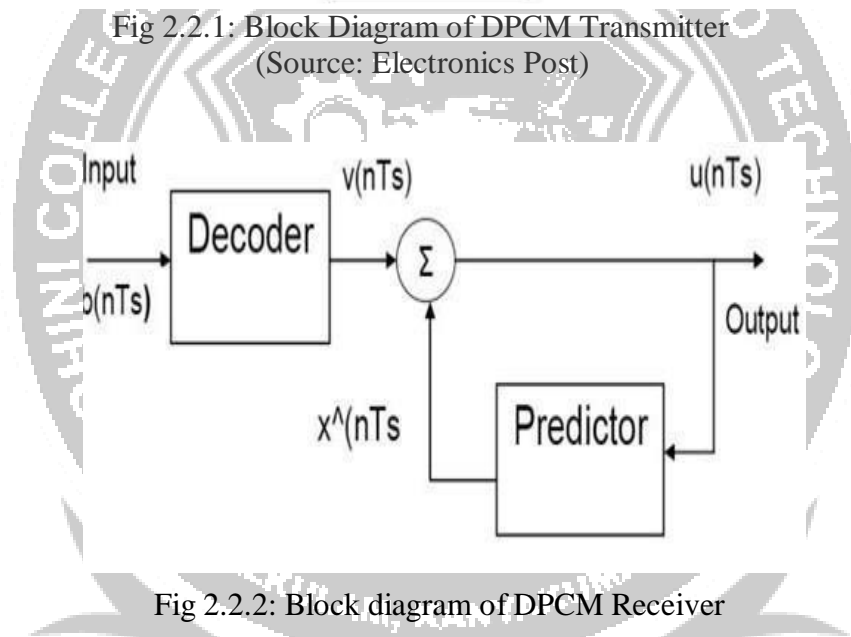

Fig 2.2.2: Block diagram of DPCM Receiver  
(Source: Electronics Post)

### Delta Modulation (DM)

Delta Modulation is a special case of DPCM. In DPCM scheme if the base band signal is sampled at a rate much higher than the Nyquist rate purposely to increase the correlation between adjacent samples of the signal, so as to permit the use of a simple quantizing strategy for constructing the encoded signal, Delta modulation (DM) is precisely such as scheme. Delta Modulation is the one-bit (or two-level) versions of DPCM.

DM provides a staircase approximation to the over sampled version of an input base band signal. The difference between the input and the approximation is quantized into only two levels, namely,  $\pm\delta$  corresponding to positive and negative differences, respectively. Thus, if the approximation falls below the signal at any sampling epoch, it is increased by  $\delta$ . Provided that the signal does not change too rapidly from sample to sample, we find that the stair case approximation remains within  $\pm\delta$  of the input signal. The symbol  $\delta$  denotes the absolute value of the two representation levels of the one-bit quantizer used in the DM.

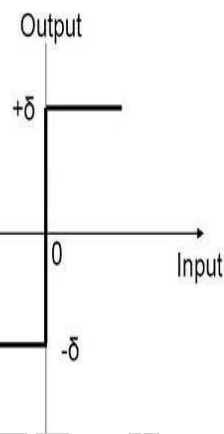

Fig 2.2.3: Input and output characteristics of Delta Modulator

(Source: Tutorials Point)

Let the input signal be  $x(t)$  and the staircase approximation to it is  $u(t)$ .

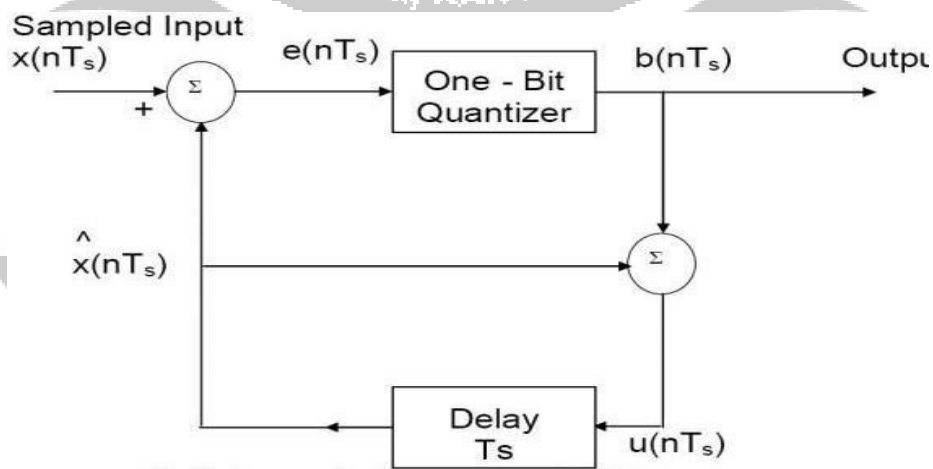

Fig 2.2.4: Block Diagram for transmitter of a DM system

(Source: Tutorials Point)

In the receiver the stair case approximation  $u(t)$  is reconstructed by passing the incoming sequence of positive and negative pulses through an accumulator in a manner similar to that used in the transmitter. The out-of-band quantization noise in the high frequency staircase waveform  $u(t)$  is rejected by passing it through a low-pass filter with a band-width equal to the original signal bandwidth. Delta modulation offers two unique features:

1. No need for Word Framing because of one-bit code word.
2. Simple design for both Transmitter and Receiver

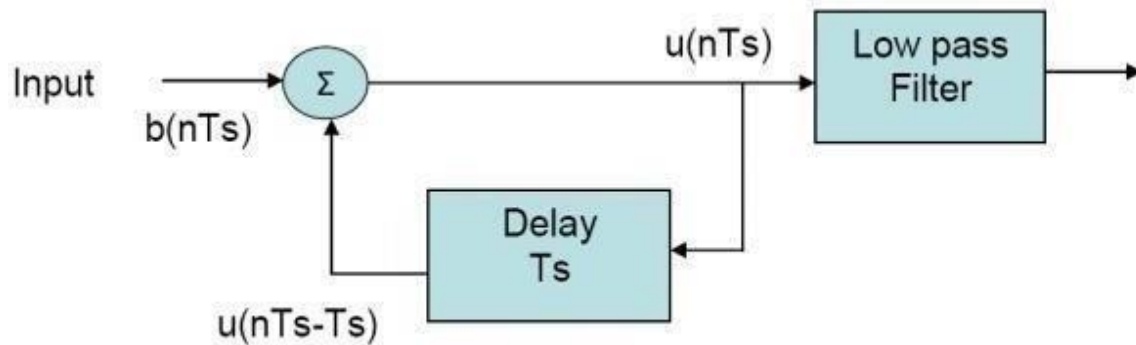

Fig 2.2.5: Block Diagram for a Receiver of a DM  
(Source: Tutorials Point)

Disadvantage of DM:

Delta modulation systems are subject to two types of quantization error:

- 1) slope –overload distortion, and
- (2) granular noise.

### **Adaptive Delta Modulation:**

The performance of a delta modulator can be improved significantly by making the step size of the modulator assume a time-varying form. In particular, during a steep segment of the input signal the step size is increased. Conversely, when the input signal is varying slowly, the step size is reduced. In this way, the size is adapted to the level of the input signal. The resulting method is called adaptive delta modulation (ADM). There are several types of ADM, depending on the type of

scheme used for adjusting the step size. In this ADM, a discrete set of values is provided for the step size.

### ADM - Transmitter

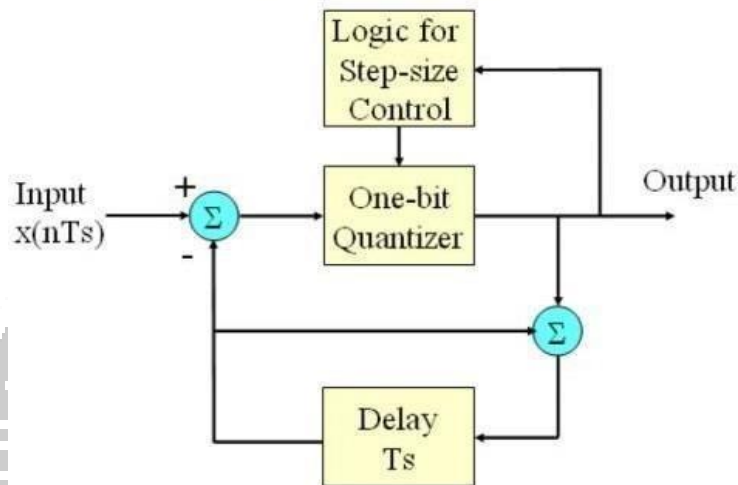

Fig 2.2.6 Block diagram of ADM Transmitter  
(Source: EIProCus)

### ADM - Receiver

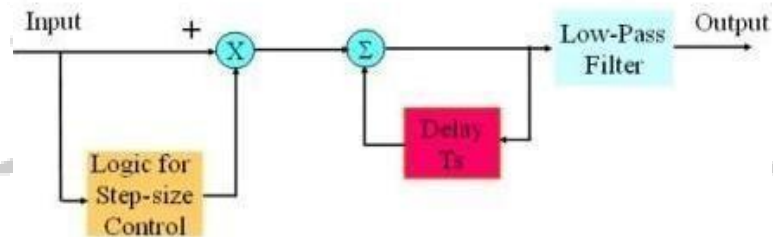

Fig 2.2.7: Block Diagram of ADM Receiver  
(Source: EIProCus)