

## Adaptive equalization

- An equalizer is a filter that compensates for the dispersion effects of a channel. Adaptive equalizer can adjust its coefficients continuously during the transmission of data.
- Pre channel equalization
- Requires feed back channel causes burden on transmission
- Equalization is process of correcting channel induced distortion. To realize the full transmission capability of telephone channel, adaptive equalization is needed. Equalizer is said to be adaptive when it adjusts itself continuously during data transmission by operating on the input signal.

Prechannel equalization is used at the transmitter and post channel equalization is used at the receiver. As prechannel equalization requires a feedback channel, adaptive equalization at the receiving side is considered. This equalization can be achieved before data transmission by training the filter with suitable training sequence transmitted through channel so as to adjust the filter parameters to optimal values.

The adaptive equalizer consists of a tapped delay line filter with 100 taps or more and its coefficients are updated according to LMS algorithm. The adjustments to the filter coefficients are made in a step by step fashion synchronously with the incoming data

### **Post channel equalization**

Achieved prior to data transmission by training the filter with the guidance of a training sequence transmitted through the channel so as to adjust the filter parameters to optimum values.

### Adaptive equalization

It consists of tapped delay line filter with set of delay elements, set of adjustable multipliers connected to the delay line taps and a summer for adding multiplier outputs in which the coefficients of filter are to be optimized using algorithms

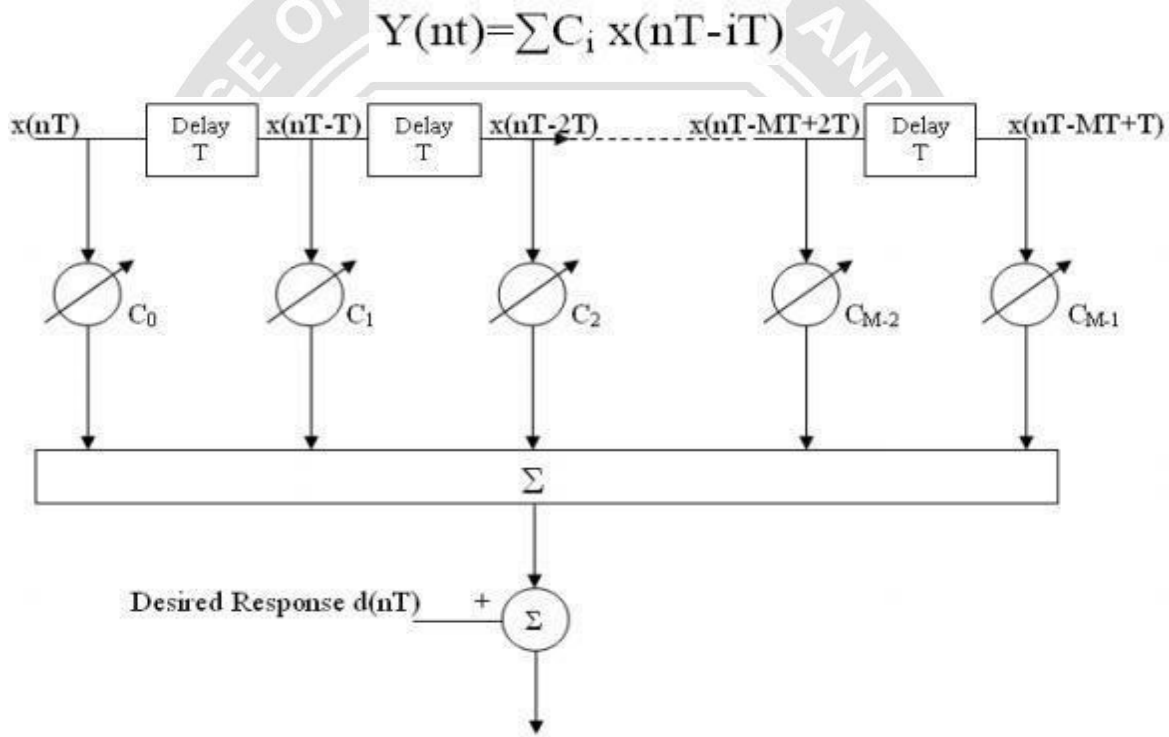

Fig 3.3.1 Adaptive equalization (Source:Brainkart)

### Mechanism of adaptation

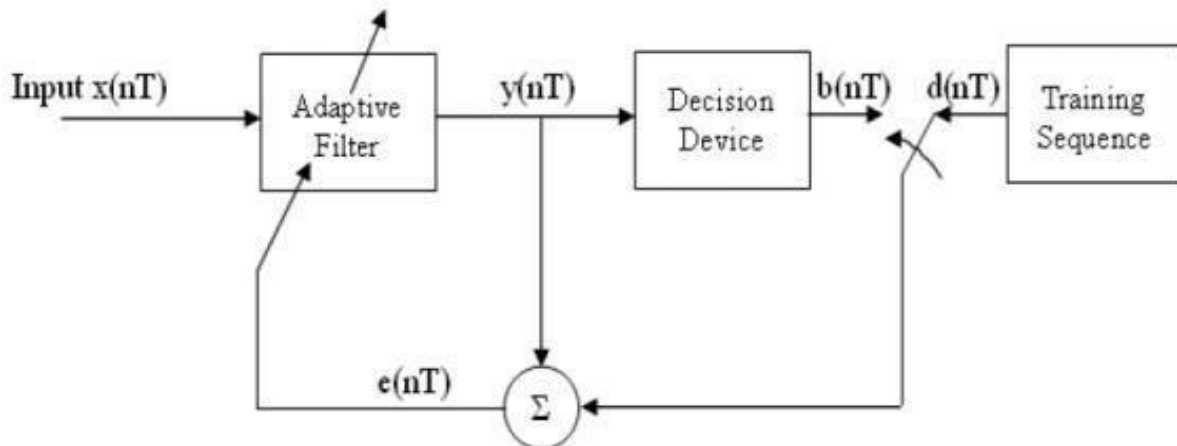

Fig 3.3.2 Mechanism of adaptation (Source: Brainkart)

Modes of operation:

(i) Training period mode (ii) decision directed mode.

### Training mode

A known sequence  $d(nT)$  is transmitted and a synchronized version of it is generated in the receiver and applied to the adaptive equalizer. This training sequence has a maximal length PN Sequence, because it has large average power and large SNR, resulting response sequence (Impulse) is observed by measuring the filter outputs at the sampling instants. The difference between the resulting response  $y(nT)$  and the desired response  $d(nT)$  is the error signal which is used to estimate the direction.

During the training period, a known sequence is transmitted and a synchronized version of the signal is generated in the receiver. It is applied to the adaptive equalizer as the desired response. The training sequence may be a Pseudo Noise sequence and the length of the training sequence may be equal to or greater than the length of the adaptive equalizer.

When the training period is completed, the adaptive equalizer is switched to decision directed mode.

OBSERVE OPTIMIZE OUTSPREAD