



ROHINI

COLLEGE OF ENGINEERING AND TECHNOLOGY

Approved by AICTE and affiliated to Anna University Chennai (An ISO Certified Institution)

Accredited by NAAC with A+ Grade

DEPARTMENT OF BIOMEDICAL ENGINEERING

BM3491 Biomedical Instrumentation

UNIT-III BIOAMPLIFIERS

3.5 Chopper amplifier, Power line interference

3.5.1 Chopper Amplifier:

When recording biopotentials noise and drift are the two problems encountered. Noise is due to the recording device and by the patient when they move. Drift is a shift in baseline created due to various thermal effects. A DC amplifier has a shift or sudden peak in the output when the input is zero. Therefore, a chopper amplifier solves the problems of drift in DC amplifiers. The name Chop means to sample the data. The amplifier circuit samples the analog signal. So it is known as **chopper amplifier**.

The general **diagram of a chopper amplifier** is as shown below. The first block chopper accepts the DC input signal and converts them to an AC signal. The AC amplifier block amplifies the chopped AC signal.

Next, in the demodulator rectifier block, an amplified chopped AC signal is converted to amplified DC signal.

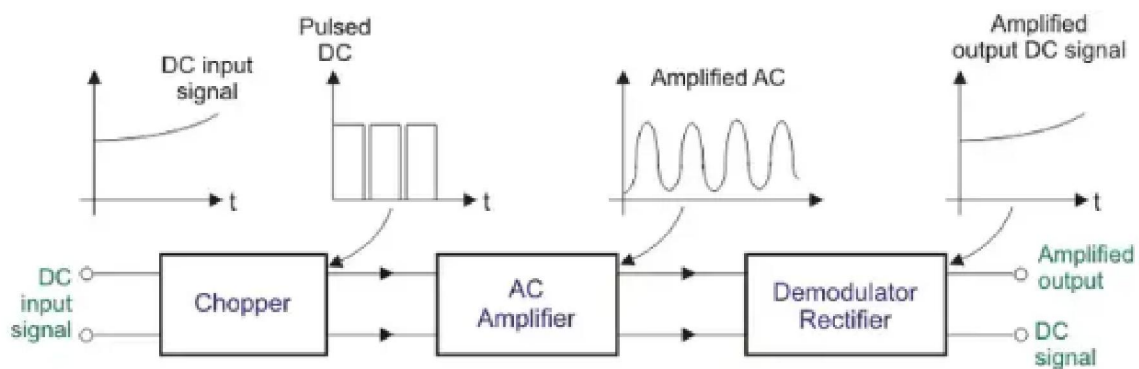

Schematic Diagram of a Chopper Amplifier

Chopper amplifier is classified into two types. Mechanical and non-mechanical choppers. The chopper converts DC or low-frequency signal to high-frequency signal. An AC amplifier amplifies the modulated high-frequency signal. The amplified signal is demodulated and filtered to obtain the low frequency or DC signal.

- i. The chopper amplifier is a useful device in the field of medical electronics as it gives another solution to the problem of achieving adequate low frequency response while avoiding the drift problem inherent in direct coupled amplifiers.
- ii. This type of amplifier makes use of a chopping device, which converts a slowly varying direct current to an alternating form with amplitude proportional to the input direct current and with phase dependent on the polarity of the original signal. The alternating voltage is then amplified by a conventional ac amplifier whose output is rectified back to get an amplified direct current. A chopper amplifier is an excellent device for signals of narrow bandwidth and reduces the drift problem
- iii. Figure shows a simplified block diagram of a single-ended chopper stabilized amplifier. The amplifier achieves its ultra-low dc offset voltage and bias current by chopping the low frequency components of the input signal, amplifying this chopped signal in an ac amplifier (A1) and then demodulating the output of the ac amplifier.
- iv. The low frequency components are derived from the input signal by passing it through the low-pass filter, consisting of R1, C1 and R2. The chopping signal is generated by the oscillator.
- v. The filtered output is then further amplified in a second stage of dc amplification (A2). High frequency signals, which are filtered out at the input of the chopper channel, are coupled directly into the second stage amplifier.
- vi. The result of this technique is to reduce the dc offsets and drift of the second amplifier by a factor equal to the gain of the chopper channel. The ac amplifier introduces no offsets. Minor offsets and bias currents exist due to imperfect chopping, but these are extremely small. The amplifier modules contain the chopper channel, including switches and switch-driving oscillator built on the module; only the dc power is supplied externally.

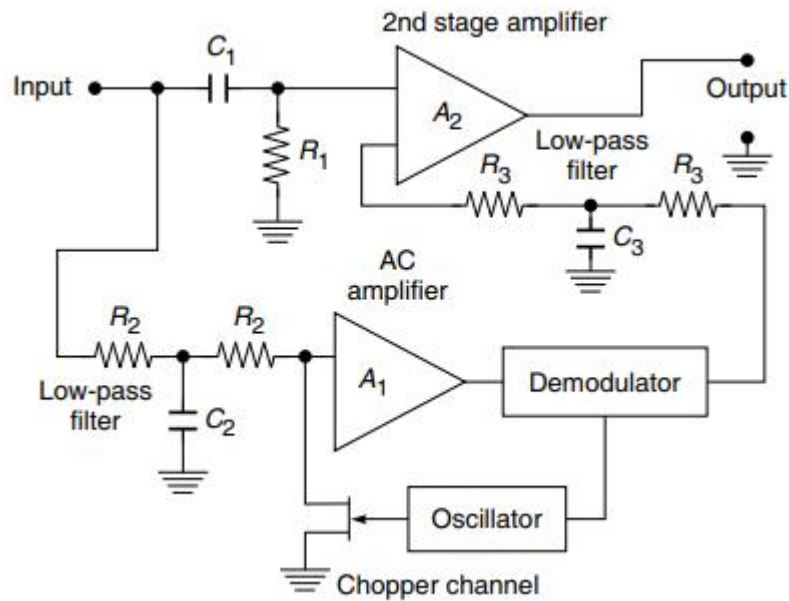

Simplified block diagram of a single ended chopper-stabilized operational amplifier

- vii. Due to the extremely low dc offset and dc drift associated with the chopper-stabilized amplifier, the signal resolution is limited only by the noise present in the circuit. Thus, it is desirable to design the feedback networks and external wiring to minimize the total circuit noise.
- viii. When the full bandwidth of the amplifier is not required, it is advisable that a feedback capacitor be used to limit the overall bandwidth and eliminate as much high frequency noise as possible. Shielding of feedback components is desirable in chopper amplifiers. It is particularly necessary in electrically noisy environments.
- ix. Use of shielded wire for summing junction leads is also recommended. Typical voltage drift in chopper-stabilised amplifiers is $0.1 \text{ mV}/0 \text{ C}$ and current drift as $0.5 \text{ pA}/\text{C}$. The great strength of the chopper-stabilized amplifier is its insensitivity to component changes due to ageing, temperature change, power supply variation or other environmental factors.
- x. Thus, it is usually the best choice where both offset voltage and bias current must be small over long periods of time or when there are significant environmental changes. Both bias current and offset voltage can be externally nulled. Chopper amplifiers are available in both single-ended as well as

differential input configurations. Chopper amplifiers find applications in the medical field in amplification of small dc signals of a few microvolts.

- xi. Such order of amplitudes are obtainable from transducers such as strain gauge pressure transducers, temperature sensors such as thermistors and strain gauge myographs, when they are used as arms of a dc Wheatstone bridge. A chopper amplifier is also suitable for use with a thermocouple.

3.5.2 Power line interference:

The power line interference of 50/60 Hz is the source of interference and it corrupts the recordings of electrocardiogram (ECG) which are extremely important for the diagnosis of patients. The interference is caused by,

- Electromagnetic interference power line.
- Electromagnetic field (EMF) by the machinery which is placed nearby, the signal component holds harmonics with different amplitude and frequency. The harmonics frequency is integral multiple of fundamental frequency such as 50Hz.
- Stray effect of the alternative current fields due to loops in the cables.
- Improper grounding of ECG machine or the patient.
- Electrical equipment's such as air conditioner, elevators and X-ray units draw heavy power line current, which induce 50Hz signals in the input circuits of the ECG machine.



The noise from electric power system is a major source of noise during the recording or monitoring of ECG. Different noises have different frequencies. The noise with low frequency is being problem with ECG signal as well as some time high frequency noises also interference ECG like mobile phone. If the physical or mathematical variable changes rapidly then it can be high frequency and if it changes slowly then it

would be low frequency. If the variable does not change at all then it is said that it has zero frequency. Most of the electronic devices such as ECG, transmitter, receiver, computer etc get power from power line. The 50Hz alternative current (AC) is reduced in voltage, rectified and then filter to obtain low voltage direct current (DC). This is used to give power to those electronic devices.

