

## HYDRAULICS AND PNEUMATICS

### Chapter – 4

#### UNIT II HYDRAULIC ACTUATORS AND CONTROL COMPONENTS

Flow control Valve, Servo and Proportional valves – Applications – Accessories :  
Reservoirs, Pressure Switches – Applications – Fluid Power ANSI Symbols.

#### HYDRAULIC SERVO SYSTEMS:

Servo systems refer to systems where automatic control of actuator movements is required. These movements should be as per a predetermined rate and deviations should be reduced to a minimum.

A servomechanism is an automatic control system designed to operate in accordance with input control parameters. The mechanism continuously compares the input signal to the feedback signal to adjust the operating conditions to correct error.

Applications: Hydraulic servo systems are widely used in the airline, maritime, and military applications. Servo systems capable of automatic position, speed, force control with high accuracy are used in high-speed injection moulding, die casting, rolling mills, presses, industrial robots, flight simulators testing machinery and table feeders.

For achieving automation, a **feedback signal**, using a **sensor**, from the actuator or any variable to be controlled such as actuator force or velocity or displacement or angle of rotation of a rotary actuator is required. This feedback signal is compared with the reference input and a suitably modified signal is sent to the flow control valve to thereby control the required variable. A block diagram representation of a hydraulic servo system is shown below.

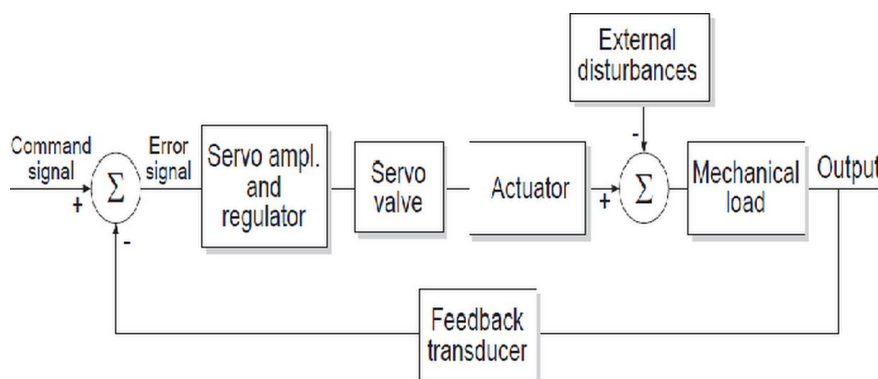

## A MECHANICAL SERVO SYSTEM:

In this system shown in the figure, load is connected to the valve spool, and special sensors and electrical components are not required.

Operation:

1. Input movement to the valve opens the spool (to left) for certain flow rate.
2. The flow actuates the piston and the load to left.
3. The load, being connected to the valve body, also moves to left, while the spool is in the same position.
4. Thus the opening of spool is gradually reduced as the piston moves. When the piston moves by the distance of initial spool movement, spool closes the port opening and flow becomes zero.
5. Thus Input movement of spool is related to the load movement.
6. Thus this arrangement provides a feed back signal.

A separate link can be connected to valve spool, cylinder rod and the input, to achieve a ratio of output/ input other than 1.

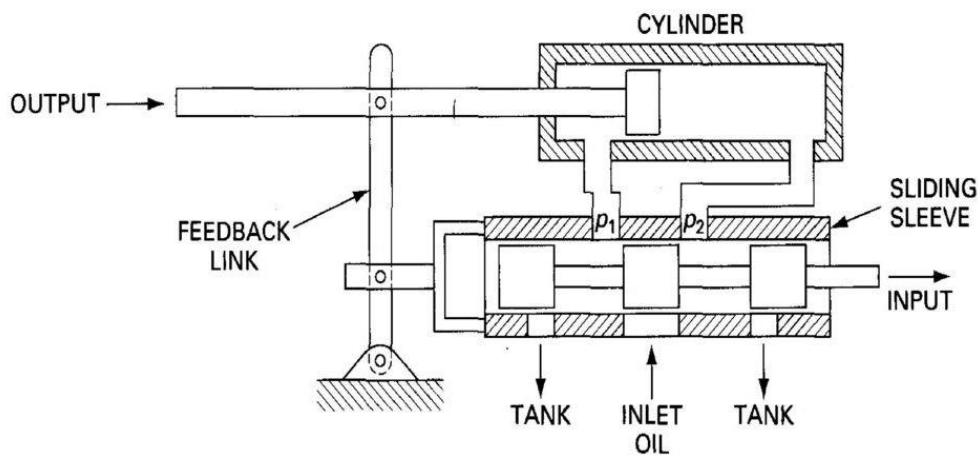

## PROPORTIONAL TYPE VALVES:

Valves explained so far are on-off type, ie, they take distinctly one of the two or three positions letting full flow in either direction or stop the flow. However for servo systems valves which operate in an analog fashion, ie continuously variable control are required. In view of the continuous control, special proportional control valves are used which produce movement of the spool proportional to an electrical signal. The signal given to the valve is the error signal (difference between the reference input and that sensed by the actuator),

so that the system corrects to make the error zero, or actuator achieves the desired parameter.

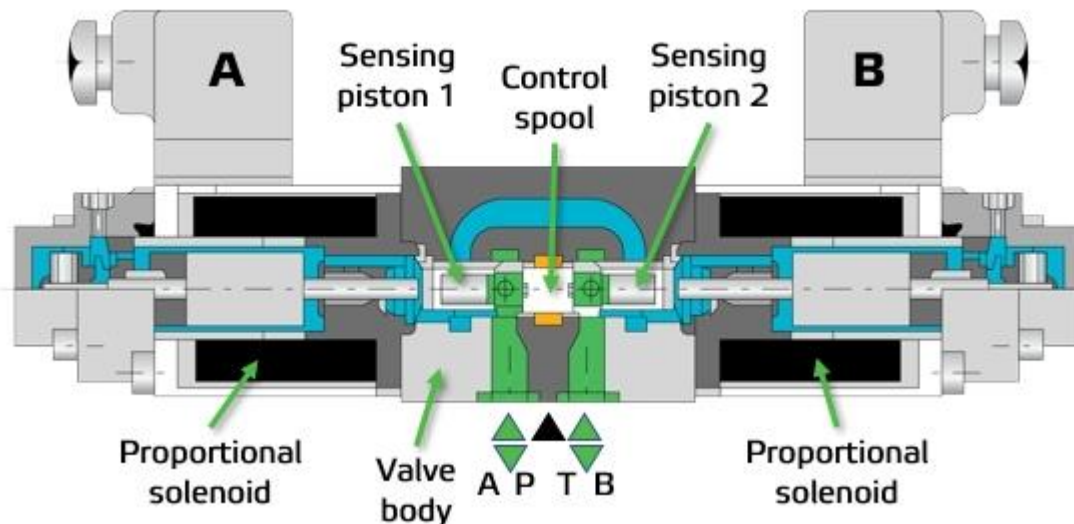

### APPLICATIONS:

Here are some common applications of Proportional Solenoid Control Valve.

**Burner/Flame Control:** Two gases must be controlled in a burner control system; both are in a desired ratio with one another. The ratio of combustion gas to oxidant gas, e. g., air or oxygen, is determined by the flame that is required for the respective process.

**Level Control with Pressurization (Flow Pressure Control):** Atmospheric pressure control is one possible type of level control. Via two solenoid control valves, a PID controller supplies enough air or nitrogen so that there is always the same pressure pressing against the fluid that changes when the fluid pressure drops through removing a portion of the fluid.

**Mixture of Cold and Warm Water:** A Pt100 temperature sensor measures the temperature of the mixed water. The temperature controller brings this temperature to the given reference value by controlling two solenoid control valves accordingly.

**Temperature Control:** A solenoid control valve can set the cold water supply to a heat exchanger in accordance with the measured process water temperature. If this is higher than the reference value, more cold water is required. If it is lower than the reference value, less cooling is required. A heating circuit works in a similar way.

**Flow Control:** A solenoid control valve can be used directly as a control valve, for direct flow control, for example. **Actuator Control (Static Pressure Control):** Two solenoid control valves can control the air for pneumatic drive (piston valve, cylinder, etc.). A PID controller determines which of the two valves must open. The control electronics set the drive via the solenoid control valves so that the process value corresponds with the set point given.

**Ejectors/Pressure Control:** A solenoid control valve can control the propellant gas flow rate. More propellant gas creates greater suction power and a deeper vacuum in the suction line. The controller sets the valve according to the vacuum pressure.

### **RESERVOIR:**

First, assuming that our new, incoming hydraulic fluid is clean of particulate contamination (not always a foregone conclusion), the reservoir should also have a filter on the fill line to insure that no contamination is introduced when filling the tank. Likewise, there is an air breather cap that allows for pressure relief as the fluid level rises or falls. this cap should be designed to eliminate introduction of particulate contamination and water ingestion (including condensation) from the air. in other words, from a contamination perspective, we should have a sealed system. in fact, some systems are designed to be truly sealed with a pressurized reservoir. regardless of the specific design, the goal is to eliminate all sources of outside contaminants. next, we should have means of reducing internally generated contaminants, usually wear debris. this is often a filter in the line from the reservoir on the suction side of the pump to insure that we protect the pump and any other downstream components. the suction line should be located and sized to eliminate the possibility for pump cavitation. Further, it should also be located in the reservoir where it is least likely to see contaminants, turbulence or hot fluid with entrained air (foam), all introduced by fluid from the return line. this usually means locating the suction line far from the return line, a few inches above the bottom and often with an inlet filter. most reservoirs have an internal baffle of some sort to help isolate the return line from the suction line. this baffle reduces turbulence from the return line, provides time for any particulates to settle and provides time for any entrained air (foam) to separate from the fluid. additionally, the baffle helps provide time for the fluid to cool. Proper reservoir design also helps to control system temperature. hydraulic systems, when working hard, generate a lot of heat. if we don't control that heat, our hydraulic fluid may begin to oxidize, and other components, such as seals, may fail due to the excessive heat. in some cases, the reservoir is sized to give the fluid time to cool before being pumped back into the system. other systems are fitted with heat exchangers to cool the fluid. Like the dictionary definition, the reservoir stores fluid, so it must also be fitted with a level gauge. this can be as simple as a sight glass or, better, a float switch that can control the fluid level between specific levels. Further, it should have an alarm system should those limits be exceeded either by a system leak or overfilling. Finally, the reservoir should be fitted with a drain and access port for cleaning and maintenance. Generally, the no. 1 source of hydraulic system failure is some kind of contamination. Clearly, a properly designed, operated and maintained reservoir is a key component

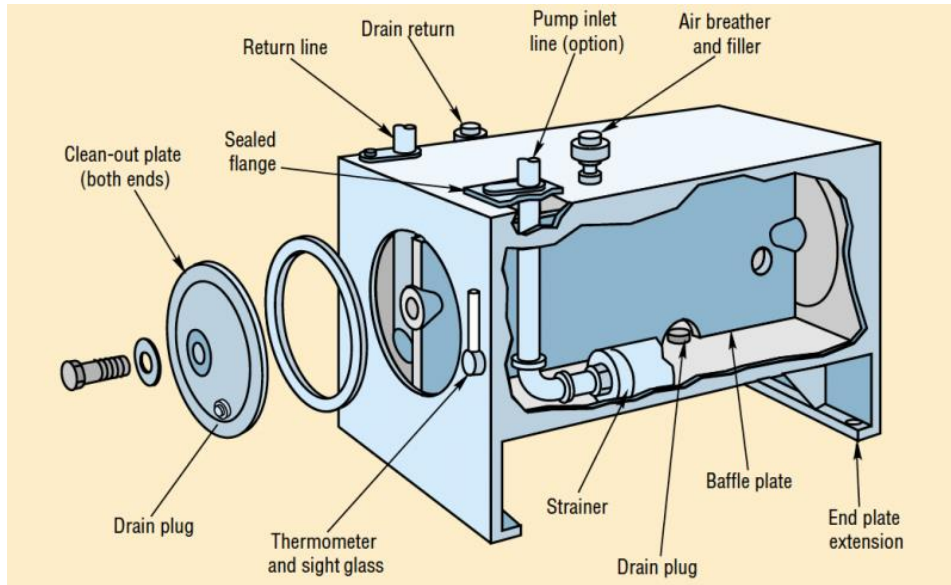

### Hydraulic pressure switches

A pressure switch is an instrument that automatically senses a change in pressure and opens or closes an electrical switching element, when a predetermined pressure point is reached. A pressure-sensing element is that part of a pressure switch that moves due to the change in pressure.

#### Operating principle

The pressure switch shown in Figure 4 is an example of a single pole double throw (SPDT) switch, which has a mechanical operation principle. All of the components are inside the switch case (F), and it has one inlet pressure port (H). In short, the inlet pressure pushes a piston (D) against a spring (C) that has a known resistant force. Then, the piston triggers the micro-switch (A), moving it between normally closed (NC) and the normally open (NO) position through an operating pin (B) and an insulated trip button (E).

The components of a pressure switch include: micro-switch (A), operating pin (B), range spring (C), operating piston (D), insulated trip button (E), switch case (F), trip setting nut (G), inlet pressure (H)

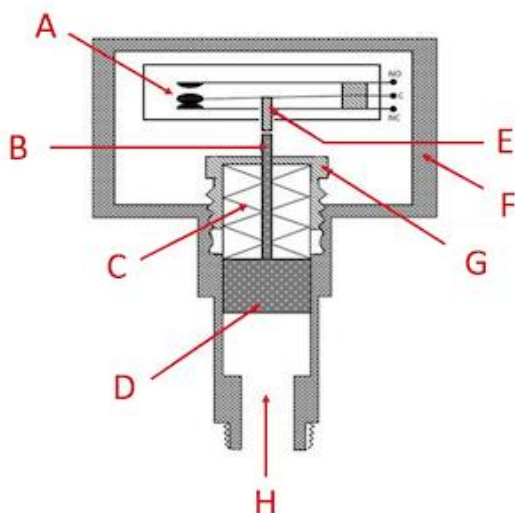

To set the pressure level at which the micro-switch switches between NC and NO, the trip-setting nut (G) changes the spring pocket depth. This depth change allows the spring resistant force to increase or decrease, which correlates to a set pressure to trigger the micro-switch. The inlet pressure (H) exerts pressure upon the operating piston (D), generating a force opposing the range spring (C). Once the inlet piston's force is higher than the opposing spring force, it pushes the operating pin (B) into the insulated trip button (E). This button then moves the micro-switch from the NC position to the NO position. If the pressure decreases below the spring force, the button, pin, and piston move away from the micro-switch, breaking the connection. The connection then goes from the NO position to the NC position.

### **Types of pressure switches**

#### **Mechanical pressure switch**

A mechanical pressure switch uses a spring and a diaphragm, or piston, to control at what pressure the micro-switch is triggered. The spring is the opposing force to the inlet pressure and the spring's pretension is adjusted with a set screw or knob. The spring pretension directly correlates to the pressure at which the switch makes an electric contact. When the pressure drops, the switch resets to its original state.

#### **APPLICATIONS:**

The mechanical pressure switch is better suited for handling high voltages and amperages than an electronic pressure switch. They can be used to make a contact change for an increase or decrease in pressure. We have an article on how to adjust mechanical pressure switches.

#### **Electronic pressure switch**

An electronic pressure switch uses an electrical pressure sensor to measure the change in inlet pressure. They have digital displays to set up the switching function. The switch point can be manufacturer set or can be programmed on-site according to the application requirements. Switch point, output signals, hysteresis, delay time, etc. are some functions that can be adjusted by the user according to the requirements.

#### **APPLICATIONS**

Electronic pressure switches are suitable for automated and controlled equipment systems that require programmable function, digital display, flexibility, accuracy, ingress protection, and stability.

#### **ANSI SYMBOLS:**

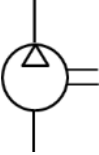
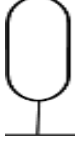
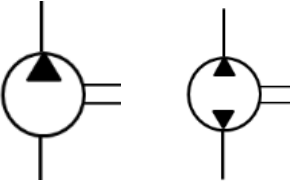
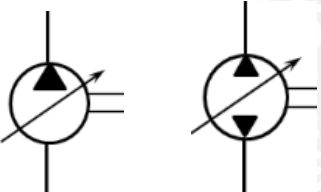
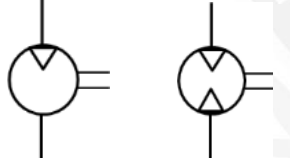
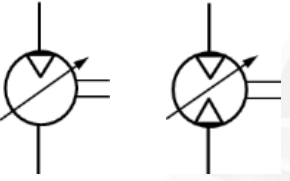
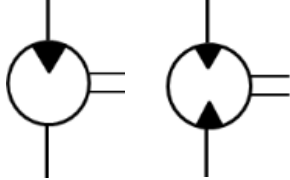
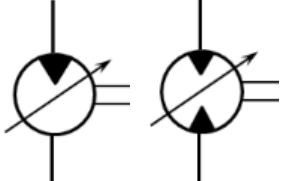
SYMBOL	DESIGNATION	EXPLANATION
<b>Energy supply</b>		
	Air compressor	One direction of rotation only with constant displacement volume
	Air receiver	Compressed air from the compressor is stored and diverted to the system when required
		One direction and two direction of rotation with constant displacement volume
	Hydraulic pump	One direction and two direction of rotation with variable displacement
<b>Rotary actuators</b>		
	Pneumatic motor	One direction and two direction of rotation with constant displacement volume
		One direction and two direction of rotation with variable displacement
	Hydraulic motor	One direction and two direction of rotation with constant displacement volume
		One direction and two direction of rotation with variable displacement
<b>Service units</b>		

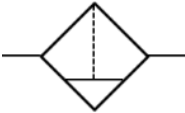
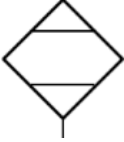
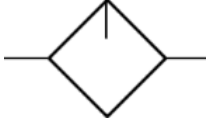
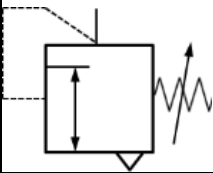
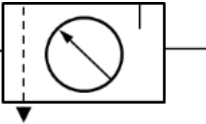
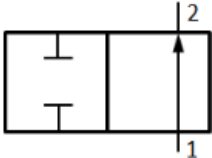
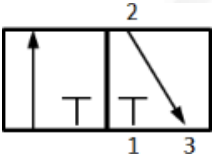
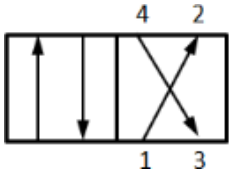
	<p>Air filter</p>	<p>This device is a combination of filter and water separator</p>
	<p>Dryer</p>	<p>For drying the air</p>
	<p>Lubricator</p>	<p>For lubrication of connected devices, small amount of oil is added to</p>
		<p>the air flowing through this device</p>
	<p>Regulator</p>	<p>To regulate the air pressure</p>
	<p>FRL unit</p>	<p>Combined filter, regulator and lubricator system</p>
<p><b>Direction control valves (DCVs)</b></p>		
	<p>2/2 way valve</p>	<p>Two closed ports in the closed neutral position and flow during actuated position</p>
	<p>3/2 way valve</p>	<p>In the first position flow takes place to the cylinder In the second position flow takes out of the cylinder to the exhaust (Single acting cylinder)</p>
	<p>4/2 way valve</p>	<p>For double acting cylinder all the ports are open</p>

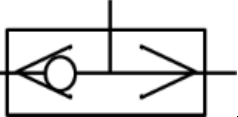
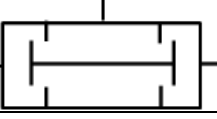
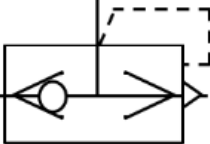
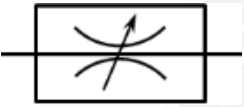
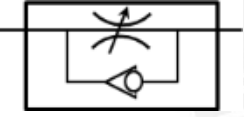
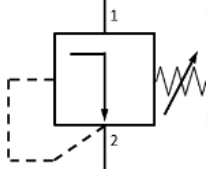
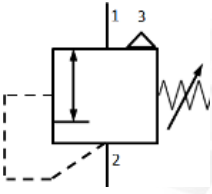
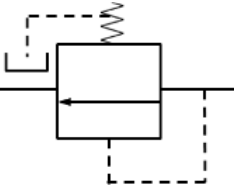
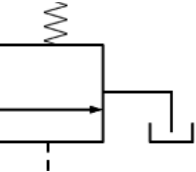

	<p>4/3 way valve</p>	<p>Two open positions and one closed neutral position</p>
	<p>5/2 way valve</p>	<p>Two open positions with two exhaust ports</p>
<p><b>Direction control valve actuation methods</b></p>		
	<p>General manual actuation</p>	<p>Manual operation of DCV</p>
	<p>Push button actuation</p>	
	<p>Lever actuation</p>	
	<p>Detent lever actuation</p>	
	<p>Foot pedal actuation</p>	
	<p>Roller lever actuation</p>	
	<p>Idle return roller actuation</p>	
	<p>Spring actuation</p>	<p>Mechanical actuation of DCV</p>
	<p>Direct pneumatic actuation</p>	
<p><b>Non return valves</b></p>		
	<p>Check valve</p>	<p>Allows flow in one direction and blocks flow in</p>

	Spring loaded check valve	other direction
	Shuttle/ OR valve	
	AND valve	
	Quick exhaust valve	
<b>Flow control valves</b>		
	Flow control valve	To allow controlled flow
	Flow control valve with one way adjustment	To allow controlled flow in one direction and free flow in other
<b>Pressure control valves</b>		
	Pressure relieving valve	
		
		
		
		Non relieving type
		Relieving type with overload being vented out
		Maintains the reduced pressure at specified location in hydraulic system
		Allows pump to build pressure to an adjustable pressure setting and then allow it to be discharged to tank



<b>Actuators</b>		
	<p>Single acting cylinder</p>	<p>Spring loaded cylinder with retraction taking place by spring force</p>
	<p>Double acting cylinder</p>	<p>Both extension and retraction by pneumatic/hydraulic force</p>

