

## UNIT I

### ANALYSIS OF BARS OF COMPOSITE SECTIONS

A bar, made up of two or more bars of equal lengths but of different materials rigidly fixed with each other and behaving as one unit for extension or contraction when subjected to an axial tensile or compressive loads, is called a composite bar.

For the composite bar the following two points are important:

1. The extension or contraction in each bar is equal. Hence deformation per unit length i.e., strain in each bar is equal.
2. The total external load on the composite bar is equal to the sum of the loads carried by each different material.

Figure shows a composite bar made up of two different materials.

Let  $P$  = Total load on the composite bar,

$L$  = Length of composite bar and also lengths of bars of different materials,

$A_1$  = Area of cross-section of bar 1,

$A_2$  = Area of cross-section of bar 2,

$E_1$  = Young's Modulus of bar 1,

$E_2$  = Young's Modulus of bar 2,

$P_1$  = Load shared by bar 1,

$P_2$  = Load shared by bar 2,

$\sigma_1$  = Stress induced in bar 1 and

$\sigma_2$  = Stress induced in bar 2

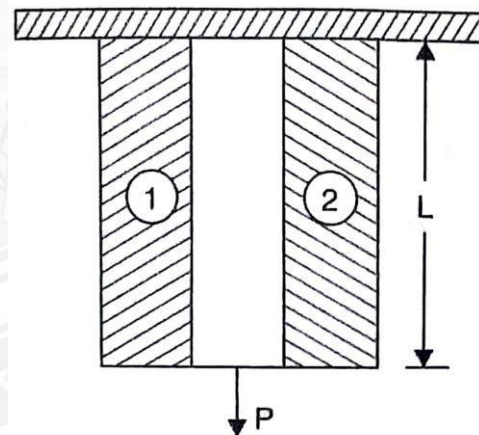

Now the total load on the composite bar is equal to the sum of the load carried by the two bars

Therefore 
$$P = P_1 + P_2 \quad \dots(i)$$

The stress in bar 1, 
$$= \frac{\text{Load carried by bar 1}}{\text{Area of cross section of bar 1}}$$

$$\sigma_1 = \frac{P_1}{A_1}$$

Or 
$$P_1 = \sigma_1 A_1 \quad \dots(ii) \quad \text{Similarly}$$

stress in bar 2, 
$$= \frac{\text{Load carried by bar 2}}{\text{Area of cross section of bar 2}}$$

$$\sigma_2 = \frac{P_2}{A_2}$$

Or 
$$P_2 = \sigma_2 A_2 \quad \dots(iii)$$

Substituting the Values of  $P_1$  and  $P_2$  in equation (i), We get

$$P = \sigma_1 A_1 + \sigma_2 A_2 \quad \dots(\text{iv})$$

Since the ends of the two bars are rigidly connected, each bar will change in length by the same amount. Also the length of each bar is same and hence the ration of change in length to the original length (*i.e.*, strain) will be same for each bar.

$$\text{But strain in bar 1,} = \frac{\text{Stress in bar 1}}{\text{Young's modulus of bar 1}} = \frac{\sigma_1}{E_1}$$

$$\text{Similarly strain in bar 2,} = \frac{\text{Stress in bar 2}}{\text{Young's modulus of bar 2}} = \frac{\sigma_2}{E_2}$$

$$\text{But strain in bar 1} = \text{Strain in bar 2}$$

$$\frac{\sigma_1}{E_1} = \frac{\sigma_2}{E_2} \quad \dots(\text{v})$$

From equations (iv) and (v), the stress  $\sigma_1$  and  $\sigma_2$  can be determined. By substituting the values of  $\sigma_1$  and  $\sigma_2$  in equations (ii) and (iii), the load carried by different materials may be computed.

**Modular Ratio.** The ratio of  $\frac{E_1}{E_2}$  is called the modular ratio of the first material to the second.

**Problem 1.2.1.** A steel rod of 3 cm diameter is enclosed centrally in a hollow copper tube of external diameter 5 cm and internal diameter of 4 cm. The composite bar is then subjected to an axial pull of 45 kN. If the length of each part is equal to 15 cm, determine:

(i) The stresses in the rod and tube, and

(ii) Load carried by each bar,

Take  $E$  for steel  $= 2.1 \times 10^5 \text{ N/mm}^2$  and for copper  $= 1.1 \times 10^5 \text{ N/mm}^2$ .

**Given Data:**

$$D_s = 3 \text{ cm} = 30 \text{ mm},$$

$$D_c = 5 \text{ cm} = 50 \text{ mm},$$

$$d_c = 4 \text{ cm} = 40 \text{ mm}$$

$$P = 45 \text{ KN} = 45000 \text{ N}$$

$$L = 15 \text{ cm} = 150 \text{ mm}$$

$$E_s = 2.1 \times 10^5 \text{ N/mm}^2$$

$$E_c = 1.1 \times 10^5 \text{ N/mm}^2$$

**To find** (i) The stress in the rod and tube, and

(ii) Load carried by each bar.

**Solution:**

Area of steel rod,

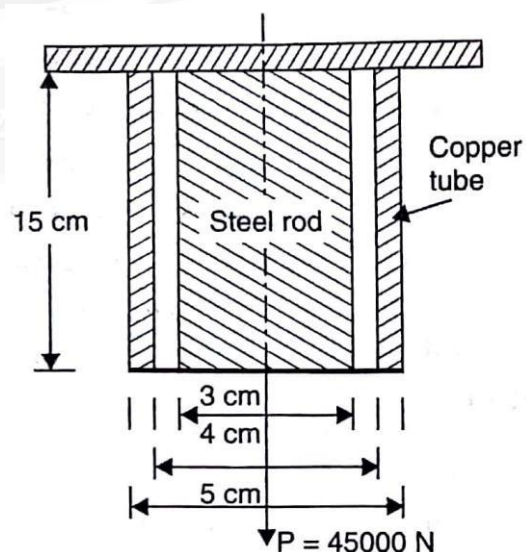

$$\begin{aligned}
 (A_s) &= \frac{\pi}{4} D_s^2 \\
 &= \frac{\pi \times 30^2}{4} = 706.86 \text{mm}^2
 \end{aligned}$$

Area of Copper tube ( $A_c$ )

$$\begin{aligned}
 &= \frac{\pi}{4} [D_c^2 - d_c^2] \\
 &= \frac{\pi}{4} [50^2 - 40^2] \\
 &= 706.86 \text{mm}^2
 \end{aligned}$$

### (i) The stress in the rod and tube

We know that,

Strain in steel = Strain in copper

or

$$\frac{\sigma_s}{E_s} = \frac{\sigma_c}{E_c}$$

$$\sigma_s = \frac{E_s}{E_c} \sigma_c = \frac{2.1 \times 10^5}{1.1 \times 10^5} \times \sigma_c = 1.909 \sigma_c \quad \dots(i)$$

Now ,

$$\text{Stress} = \frac{\text{Load}}{\text{Area}}$$

$$\therefore \text{Load} = \text{Stress} \times \text{Area}$$

Load on steel + Load on copper = Total Load

$$\sigma_s \times A_s + \sigma_c \times A_c = P$$

$$1.909 \sigma_c \times 706.86 + \sigma_c \times 706.86 = 45000$$

$$\sigma_c (1.909 \times 706.86 + 706.86) = 45000$$

$$2056.25 \sigma_c = 45000$$

$$\sigma_c = \frac{45000}{2056.25} = \mathbf{21.88 \text{ N/mm}^2}$$

Substituting the value of  $\sigma_c$  in equation (i), we get

$$\begin{aligned}
 \sigma_s &= 1.909 \times 21.88 \\
 &= \mathbf{41.77 \text{ N/mm}^2}
 \end{aligned}$$

### (ii) Load carried by each bar

As  $\text{Load} = \text{Stress} \times \text{Area}$

$$\therefore \text{Load carried by steel rod, } P_s = \sigma_s \times A_s$$

$$= 41.77 \times 706.86$$

$$= \mathbf{29525.5 \text{ N}}$$

Load Carried by copper tube,  $P_c = P - P_s$

$$\begin{aligned}
 &= 45000 - 29525.5 \\
 &= \mathbf{15474.5 \text{ N}}
 \end{aligned}$$

**Problem 1.2.2.** Two vertical rods one of steel and the other of copper are rigidly fixed at the top and 50 cm apart. Diameters and lengths of each rod are 2 cm and 400 cm respectively. A cross bar fixed to the rods at the lower ends carries a load of 5 kN such that the cross bar remains horizontal ever after loading. Find the stress in each rod and the position of the load on the bar. Take  $E$  for steel =  $2 \times 10^5 \text{ N/mm}^2$  and  $E$  for copper =  $1 \times 10^5 \text{ N/mm}^2$ .

**Given Data:**

$$D_s = D_c = 2 \text{ cm} = 20 \text{ mm},$$

$$P = 5 \text{ kN} = 5000 \text{ N}$$

$$L = 400 \text{ cm} = 4000 \text{ mm}$$

$$E_s = 2 \times 10^5 \text{ N/mm}^2$$

$$E_c = 1 \times 10^5 \text{ N/mm}^2$$

$$S = 50 \text{ cm} = 500 \text{ mm}$$

**To find** (i) The stress in each rod and  
(ii) Position of the load.

**Solution:**

Area of steel rod ( $A_s$ ) = Area of copper rod ( $A_c$ )

$$= \frac{\pi D_s^2}{4}$$

$$= \frac{\pi \times 20^2}{4}$$

$$= 314.16 \text{ mm}^2$$

**(i) The stress in each rod.**

We Know that,

$$\text{Strain in steel} = \text{Strain in copper}$$

or

$$\frac{\sigma_s}{E_s} = \frac{\sigma_c}{E_c}$$

$$\sigma_s = \frac{\sigma_c E_s}{E_c} = \frac{2 \times 10^5}{1 \times 10^5} \times \sigma_c = 2 \sigma_c \quad \dots(i)$$

$$\text{Now,} \quad \text{Stress} = \frac{\text{Load}}{\text{Area}} \quad \therefore \text{Load} = \text{Stress} \times \text{Area}$$

Load on steel + Load on copper = Total Load

$$\sigma_s \times A_s + \sigma_c \times A_c = P$$

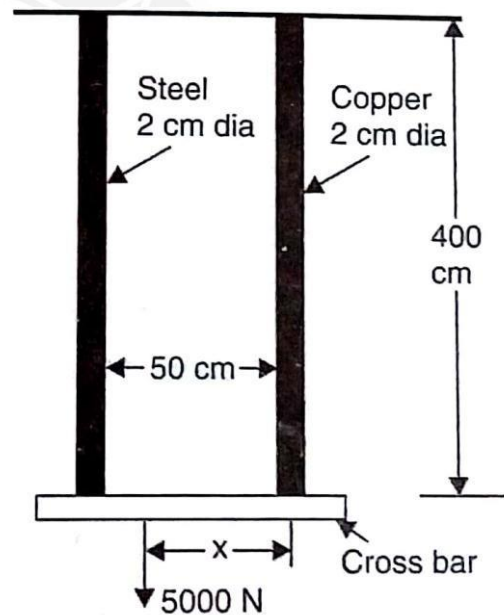

$$2\sigma_c \times 314.16 + \sigma_c \times 314.16 = 45000$$

$$\sigma_c(2 \times 314.16 + 314.16) = 5000$$

$$942.48\sigma_c = 5000$$

$$\sigma_c = \frac{5000}{942.48} = \mathbf{5.31 \text{ N/mm}^2}.$$

Substituting the value of  $\sigma_c$  in equation (i), we get

$$\sigma_s = 2 \times 5.31 = \mathbf{10.62 \text{ N/mm}^2}.$$

**(ii) Position of the load of 5KN on cross bar**

Let,  $X$  = The distance of 5 kN load from the copper rod

Now first calculate the load carried by each rod.

As  $\text{Load} = \text{Stress} \times \text{Area}$

$$\begin{aligned} \therefore \text{Load carried by steel rod, } P &= \sigma_s \times A_s \\ &= 10.62 \times 314.16 \\ &= \mathbf{3336.38 \text{ N}}. \end{aligned}$$

$$\begin{aligned} \text{Load Carried by copper rod, } P_c &= P - P_s \\ &= 5000 - 3336.38 \\ &= \mathbf{1663.62 \text{ N}} \end{aligned}$$

Now taking the moments about the copper rod and equating the same, we get

$$\begin{aligned} 5000 \times X &= P_s \times 50 \\ &= 3336.38 \times 50 \\ \therefore X &= \frac{3336.38 \times 50}{5000} \\ &= \mathbf{33.36 \text{ cm}} \text{ from the copper rod.} \end{aligned}$$

**Problem 1.2.3.** A load of 2MN is applied on a short concrete column 500mm  $\times$  500mm. The column is reinforced with four steel bars of 10mm diameter, one in each corner. Find the stresses in concrete and steel bars. Take  $E$  for steel as  $2.1 \times 10^5 \text{ N/mm}^2$  and for concrete as  $1.4 \times 10^4 \text{ N/mm}^2$ .

**Given Data:**

$$\text{Load } P = 2 \text{ kN} = 2 \times 10^6 \text{ N}$$

$$\text{Size of column} = 500 \text{ mm} \times 500 \text{ mm}$$

$$\text{Dia of steel rod} = 10 \text{ mm}$$

$$\text{No. of Steel bars} = 4$$

$$E_s = 2.1 \times 10^5 \text{ N/mm}^2$$

$$E_c = 1.4 \times 10^4 \text{ N/mm}^2$$

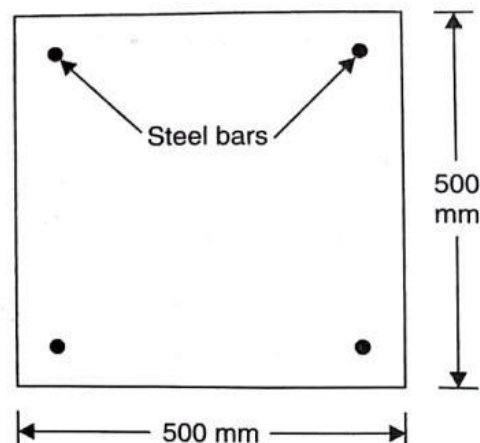

**To find :**

The stress in concrete and steel bars

**Solution:**

$$\begin{aligned} \text{Area of steel bars}(A_s) &= 4 \times \frac{\pi D^2}{4} \\ &= 4 \times \frac{\pi \times 20^2}{4} \\ &= 314.16 \text{ mm}^2 \end{aligned}$$

$$\text{Area of column} = 500 \times 500 = 250000 \text{ mm}^2$$

$$\begin{aligned} \text{Area of Concrete}(A_c) &= \text{Area of column} - \text{Area of steel bars} \\ &= 250000 - 314.16 \\ &= 249685.84 \text{ mm}^2 \end{aligned}$$

We Know that,

$$\text{Strain in steel} = \text{Strain in concrete}$$

$$\text{or} \quad \frac{\sigma_s}{E_s} = \frac{\sigma_c}{E_c}$$

$$\sigma_s = \frac{E_s}{E_c} \times \sigma_c = \frac{2.1 \times 10^5}{1.4 \times 10^4} \times \sigma_c = 15 \sigma_c \quad \dots(i)$$

$$\text{Now,} \quad \text{Stress} = \frac{\text{Load}}{\text{Area}}$$

$$\therefore \quad \text{Load} = \text{Stress} \times \text{Area}$$

$$\text{Load on steel} + \text{Load on concrete} = \text{Total Load}$$

$$\sigma_s \times A_s + \sigma_c \times A_c = P$$

$$\text{or} \quad 15\sigma_c \times 314.16 + \sigma_c \times 249685.84 = 2 \times 10^6$$

$$\sigma_c(15 \times 314.16 + 249685.84) = 2 \times 10^6$$

$$254398.24 \sigma_c = 2 \times 10^6$$

$$\sigma_c = \frac{2 \times 10^6}{254398.24}$$

$$= 7.86 \text{ N/mm}^2.$$

Substituting the value of  $\sigma_c$  in equation (i), we get

$$\sigma_s = 15 \times 7.86$$

$$= 117.93 \text{ N/mm}^2.$$

**Problem 1.2.4** A reinforced short concrete column 250 mm × 250 mm in section is reinforced with 8 steel bars. The total area of steel bars is 2500 mm<sup>2</sup>. The column carries a load of 390



kN. If the modulus of Elasticity for steel is 15 times that of concrete, find the stresses in concrete and steel.

**Given Data:**

Size of column	=	250 mm × 250mm
Load, P	=	390 kN = 390 × 10 <sup>3</sup> N
Area of steel, (A <sub>s</sub> )	=	2500mm <sup>2</sup>
No. of Steel bars	=	8
E <sub>s</sub>	=	15 E <sub>c</sub>

**To find :** The stress in concrete and steel bars

**Solution:**

$$\begin{aligned} \text{Area of column} &= 250 \times 250 = 62500 \text{ mm}^2 \\ \text{Area of Concrete (A}_c) &= \text{Area of column} - \text{Area of steel bars} \\ &= 62500 - 2500 \\ &= 60000 \text{ mm}^2 \end{aligned}$$

We Know that,

Strain in steel = Strain in concrete

$$\begin{aligned} \text{or} \quad \frac{\sigma_s}{E_s} &= \frac{\sigma_c}{E_c} \\ \sigma_s &= \frac{E_s}{E_c} \sigma_c = 15 \sigma_c \quad \dots(i) \end{aligned}$$

$$\text{Now, Stress} = \frac{\text{Load}}{\text{Area}} \quad \therefore \text{Load} = \text{Stress} \times \text{Area}$$

$$\text{Load on steel} + \text{Load on concrete} = \text{Total Load}$$

$$\sigma_s \times A_s + \sigma_c \times A_c = P$$

$$\text{or} \quad 15 \sigma_c \times 2500 + \sigma_c \times 60000 = 390 \times 10^3$$

$$\sigma_c (15 \times 2500 + 60000) = 390 \times 10^3$$

$$97500 \sigma_c = 390 \times 10^3$$

$$\sigma_c$$

$$= \frac{390 \times 10^3}{97500} = 4.0 \text{ N/mm}^2.$$

Substituting the value of  $\sigma_c$  in equation (i), we

$$\begin{aligned} \sigma_s &= 15 \times 4.0 \\ &= 60.0 \text{ N/mm}^2. \end{aligned}$$

**Problem 1.2.5.** A steel rod and two copper rods together support a load of 370kN as shown in

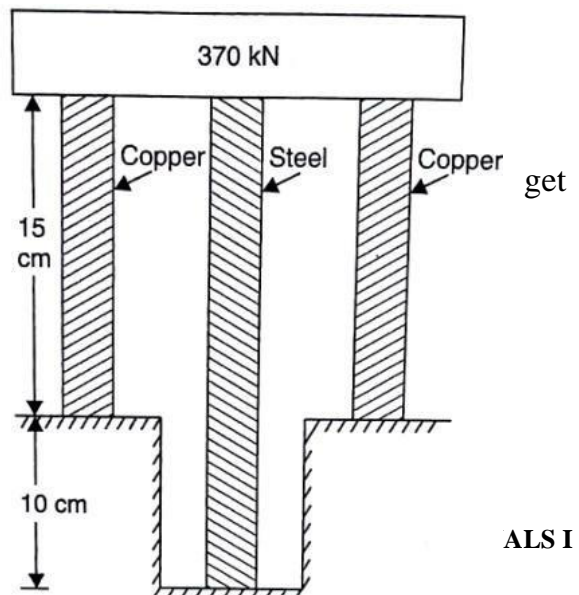

figure. The cross sectional area of steel rod is  $2500 \text{ mm}^2$  and of each copper rod is  $1600 \text{ mm}^2$ . Find the stresses in the rods. Take  $E$  for steel =  $2 \times 10^5 \text{ N/mm}^2$  and for copper =  $1 \times 10^5 \text{ N/mm}^2$ .

**Given Data:**

$$P = 370 \text{ kN} = 370000 \text{ N}$$

$$L_c = 15 \text{ cm} = 150 \text{ mm}$$

$$L_s = 25 \text{ cm} = 250 \text{ mm}$$

$$A_s = 2500 \text{ mm}^2$$

$$A_c = 2 \times 1600 = 3200 \text{ mm}^2$$

$$E_s = 2 \times 10^5 \text{ N/mm}^2$$

$$E_c = 1 \times 10^5 \text{ N/mm}^2$$

**To find**

The stresses in each rod

**Solution:**

We Know that,

Change in length of steel rod = Change in length of copper rod

$$\text{or} \quad \frac{\sigma_s}{E_s} L_s = \frac{\sigma_c}{E_c} L_c$$

$$\sigma_s = \frac{\sigma_c \times L_c \times E_s}{E_c \times L_s}$$

$$= \frac{\sigma_c \times 150 \times 2 \times 10^5}{1 \times 10^5 \times 250} \times \sigma_c$$

$$= 1.2 \sigma_c \quad \dots(i)$$

$$\text{Now,} \quad \text{Stress} = \frac{\text{Load}}{\text{Area}} \quad \therefore \text{Load} = \text{Stress} \times \text{Area}$$

Load on steel + Load on copper = Total Load

$$\sigma_s \times A_s + \sigma_c \times A_c = P$$

$$1.2 \sigma_c \times 2500 + \sigma_c \times 3200 = 370000$$

$$\sigma_c (1.2 \times 2500 + 3200) = 370000$$

$$6200 \sigma_c = 370000$$

$$\sigma_c = \frac{370000}{6200} = \mathbf{59.67 \text{ N/mm}^2}$$

Substituting the value of  $\sigma_c$  in equation (i), we get

$$\sigma_s = 1.2 \times 59.67$$

$$= \mathbf{71.604 \text{ N/mm}^2}$$



**Problem 1.2.6.** Three bars made of copper, zinc and aluminium are of equal length and have cross-section 500, 750 and 1000 square mm respectively. They are rigidly connected at their ends. If the compound member is subjected to a longitudinal pull of 250 kN. Estimate the proportional of the load carried on each rod and the induced stresses. Take the value of E for copper =  $1.3 \times 10^5$  N/mm<sup>2</sup>, for zinc =  $1.0 \times 10^5$  N/mm<sup>2</sup> and for aluminium =  $0.8 \times 10^5$  N/mm<sup>2</sup>.

**Given**

$$A_c = 500 \text{ mm}^2$$

$$A_z = 750 \text{ mm}^2$$

$$A_a = 1000 \text{ mm}^2$$

$$P = 250 \text{ kN} = 250000 \text{ N}$$

$$E_c = 1.3 \times 10^5 \text{ N/mm}^2$$

$$E_z = 1.0 \times 10^5 \text{ N/mm}^2$$

$$E_a = 0.8 \times 10^5 \text{ N/mm}^2$$

**To find**

- (i) The stress in the each rod and
- (ii) Load carried by each rod.

**Solution:**

**(i) The stress in the rod and tube**

We Know that,

$$\text{Strain in copper} = \text{Strain in zinc} = \text{Strain in aluminium}$$

$$\text{or } \frac{\sigma_c}{E_c} = \frac{\sigma_z}{E_z} = \frac{\sigma_a}{E_a}$$

$$\sigma_c = \frac{E_c}{E_a} \sigma_a = \frac{1.3 \times 10^5}{0.8 \times 10^5} \times \sigma_a = 1.625 \sigma_a \quad \dots (i)$$

$$\text{Also, } \sigma_z = \frac{E_z}{E_a} \sigma_a = \frac{1.0 \times 10^5}{0.8 \times 10^5} \times \sigma_a = 1.25 \sigma_a \quad \dots (ii)$$

$$\text{Now, } \text{Stress} = \frac{\text{Load}}{\text{Area}} \quad \therefore \text{Load} = \text{Stress} \times \text{Area}$$

$$\text{Load on copper} + \text{Load on zinc} + \text{Load on aluminium} = \text{Total Load}$$

$$\sigma_c \times A_c + \sigma_z \times A_z + \sigma_a \times A_a = P$$

$$\text{or } 1.625 \sigma_a \times 500 + 1.25 \sigma_a \times 750 + \sigma_a \times 1000 = 250000 \text{ N}$$

$$\text{or } 2750 \sigma_a = 250000$$

$$\sigma_a = \frac{250000}{2750}$$

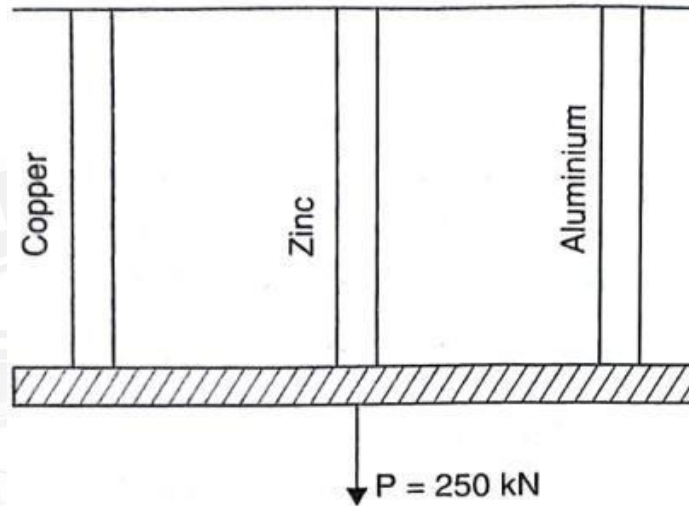

$$= 90.9 \text{ N/mm}^2.$$

Substituting the value of  $\sigma_c$  in equation (i) and (ii) we get

$$\sigma_c = 1.625 \times 90.9 = 147.7 \text{ N/mm}^2.$$

and

$$\sigma_z = 1.25 \times 90.9 = 113.625 \text{ N/mm}^2.$$

**(ii) Load carried by each bar**

$$\text{As} \quad \text{Load} = \text{Stress} \times \text{Area}$$

$$\begin{aligned} \text{Now,} \quad \text{Load carried by copper rod, } P_c &= \sigma_c \times A_c \\ &= 147.7 \times 500 = 73850 \text{ N.} \end{aligned}$$

$$\begin{aligned} \text{Load carried by zinc rod, } P_z &= \sigma_z \times A_z \\ &= 113.625 \times 750 = 85218 \text{ N} \end{aligned}$$

$$\begin{aligned} \text{Load carried by aluminium rod, } P_a &= \sigma_a \times A_a \\ &= 90.9 \times 1000 = 90900 \text{ N} \end{aligned}$$

