

Pulse Width Modulation

Pulse Width Modulation (PWM) or Pulse Duration Modulation (PDM) or Pulse Time Modulation (PTM) is an analog modulating scheme in which the duration or width or time of the pulse carrier varies proportional to the instantaneous amplitude of the message signal.

The width of the pulse varies in this method, but the amplitude of the signal remains constant. Amplitude limiters are used to make the amplitude of the signal constant. These circuits clip off the amplitude, to a desired level and hence the noise is limited. The following figures explain the types of Pulse Width Modulations. Fig 5.4.1 (a), (b),(c) Pulse Width Modulated Waves with different time slots.

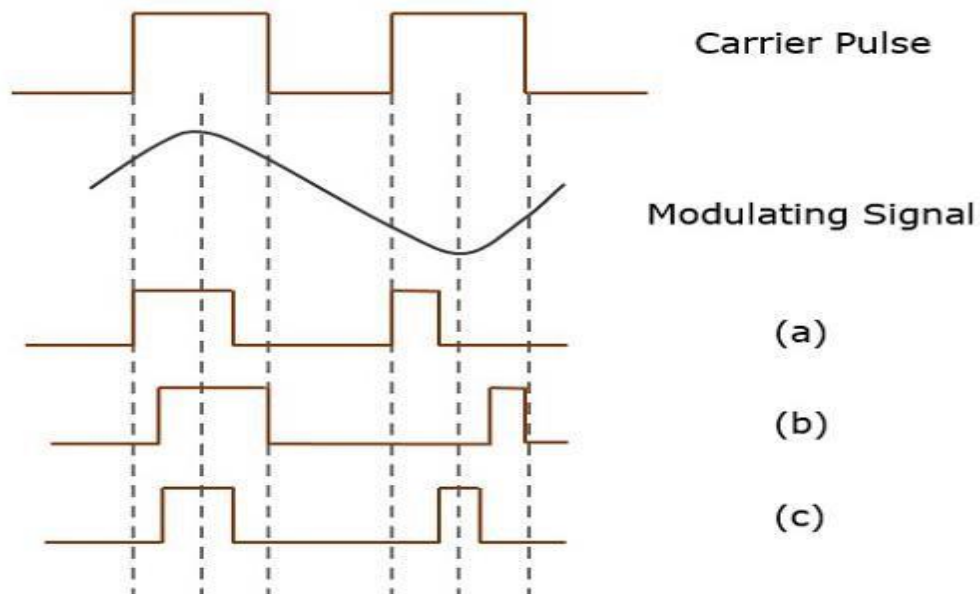

Figure 5.4.1 (a), (b),(c) Pulse Width Modulated Waves with different time slots

Diagram Source Brain Kart

There are three variations of PWM. They are –

The leading edge of the pulse being constant, the trailing edge varies according to the message signal. The trailing edge of the pulse being constant, the leading edge varies according to the message signal. The center of the pulse being constant, the leading edge and the trailing edge varies according to the message signal. These three types are shown in the above given figure, with timing slots.

Pulse Width Modulation (PWM) Waveform Representation

In PWM, the width of the modulated pulses varies in proportion with the amplitude of modulating signal. The waveforms of PWM is shown in fig.1 below.

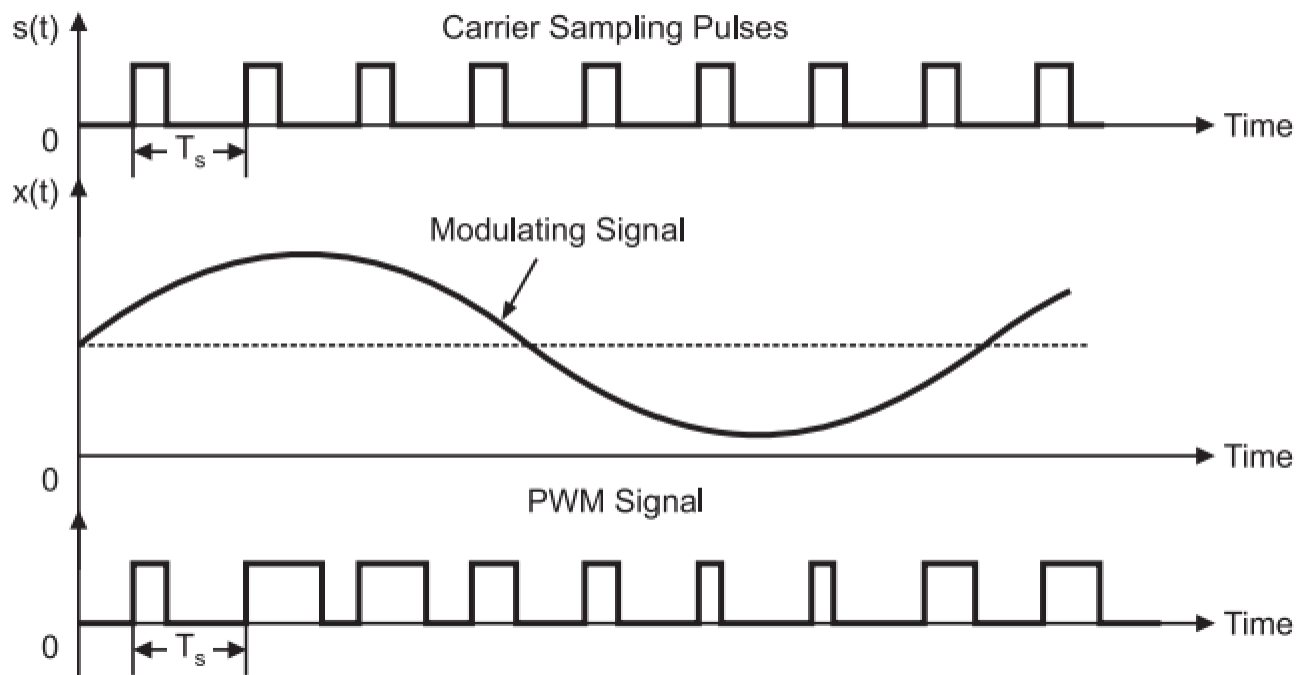

Figure.5.4.2 :Wave form Representations of PWM

Diagram Source Brain Kart

As we can observe, the amplitude and the frequency of the PWM wave remain constant. Only the width changes. That is why the information is contained in the width variation. This is similar to FM. As the noise is normally additive noise, it

changes the amplitude of the PWM signal. Fig.5.4.2 Wave form Representations of PWM.

At the receiver, it is possible to remove these unwanted amplitude variations very easily by means of a limiter circuits. As the information is contained in the width variation, it is unaffected by the amplitude variations introduced by the noise. Thus, the PWM system is more immune to noise than the PAM signal.

Generation of PWM Signal

The block diagram of a PWM signal generator is shown in fig.5.4.3 below. This circuit can also be used for the generation of PPM signal.

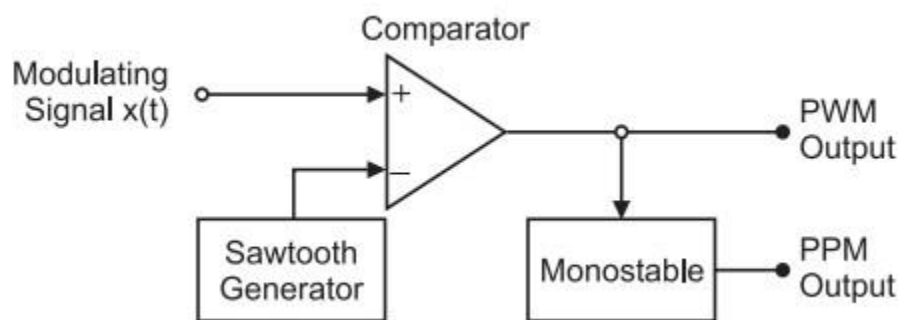

Figure.5.4.3 : PWM Generator

Diagram Source Brain Kart

A sawtooth generator generates a sawtooth signal of frequency f_s , and this sawtooth signal in this case is used as a sampling signal. It is applied to the inverting terminal of a comparator. The modulating signal $x(t)$ is applied to the non-inverting terminal of the same comparator. The comparator output will remain high as long as the instantaneous amplitude of $x(t)$ is higher than that of the ramp signal. This gives rise to a PWM signal at the comparator output as shown in fig.5.4.4.

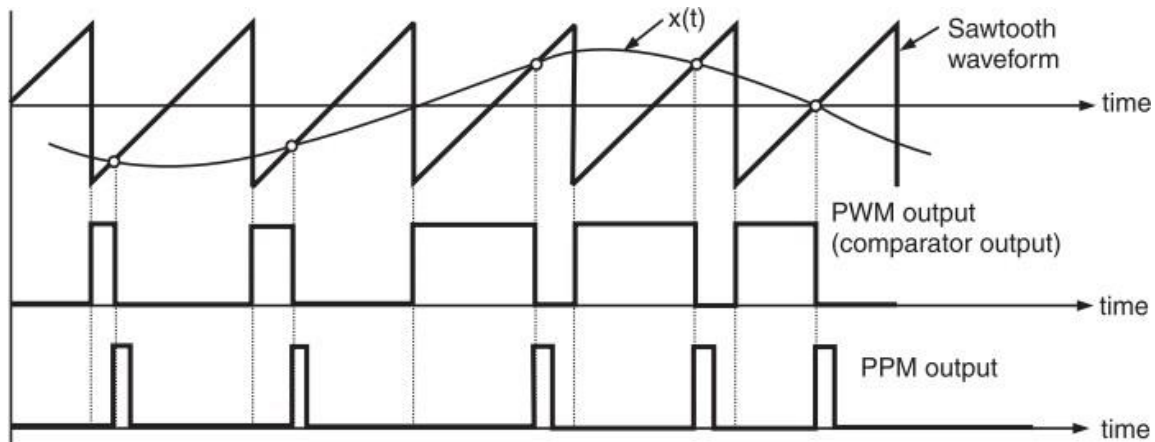

Figure.5.4.4: Waveforms of PWM and PPM

Diagram Source Brain Kart

Here, it may be noted that the leading edges of the PWM waveform coincide with the falling edges of the ramp signal. Thus, the leading edges of PWM signal are always generated at fixed time instants. However, the occurrence of its trailing edges will be dependent on the instantaneous amplitude of $x(t)$. Therefore, this PWM signal is said to be trail edge modulated PWM.

Detection of PWM Signal

The circuit for the detection of PWM signal is shown in fig.5.4.5 below.

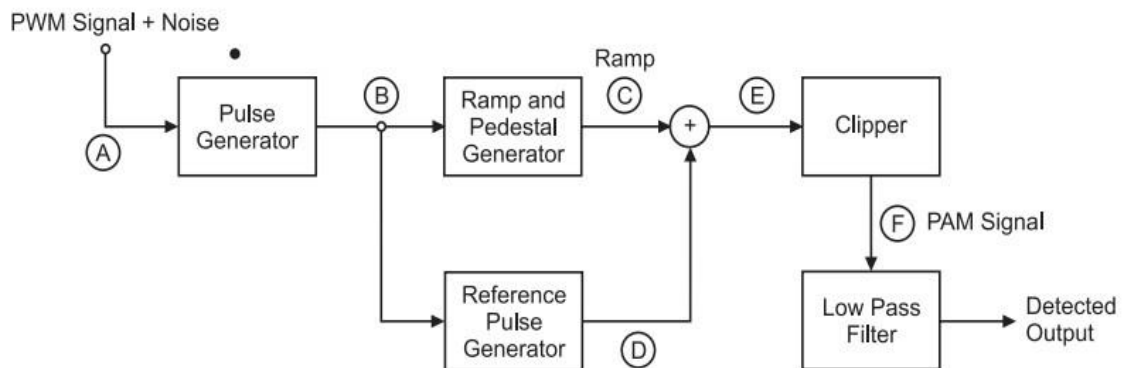

Figure.5.4.5 : PWM Detection Circuit

Diagram Source Brain Kart

The working operation of the circuit may be explained as under: The PWM signal received at the input of the detection circuit is contaminated with noise. This signal is applied to pulse generator circuit which regenerates the PWM signal. Thus, some of the noise is removed and the pulses are squared up. The regenerated pulses are applied to a reference pulse generator. It produces a train of constant amplitude, constant width pulses. These pulses are synchronized to the leading edges of the regenerated PWM pulses but delayed by a fixed interval. The regenerated PWM pulses are also applied to a ramp generator. At the output of it, we get a constant slope ramp for the duration of the pulse. The height of the ramp is thus proportional to the width of the PWM pulses. At the end of the pulse, a sample and hold amplifier retains the final ramp voltage until it is reset at the end of the pulse. The constant amplitude pulses at the output of reference pulse generator are then added to the ramp signal. The output of the adder is then clipped off at a threshold level to generate a PAM signal at the output of the clipper. A low pass filter is used to recover the original modulating signal back from the PAM signal. The waveforms for this circuit have been shown in fig.5.4.6.

Advantages of PWM

Less effect of noise i.e., very good noise immunity. Synchronization between the transmitter and receiver is not essential (Which is essential in PPM). It is possible to reconstruct the PWM signal from a noise, contaminated PWM, as discussed in the detection circuit. Thus, it is possible to separate out signal from noise (which is not possible in PAM).

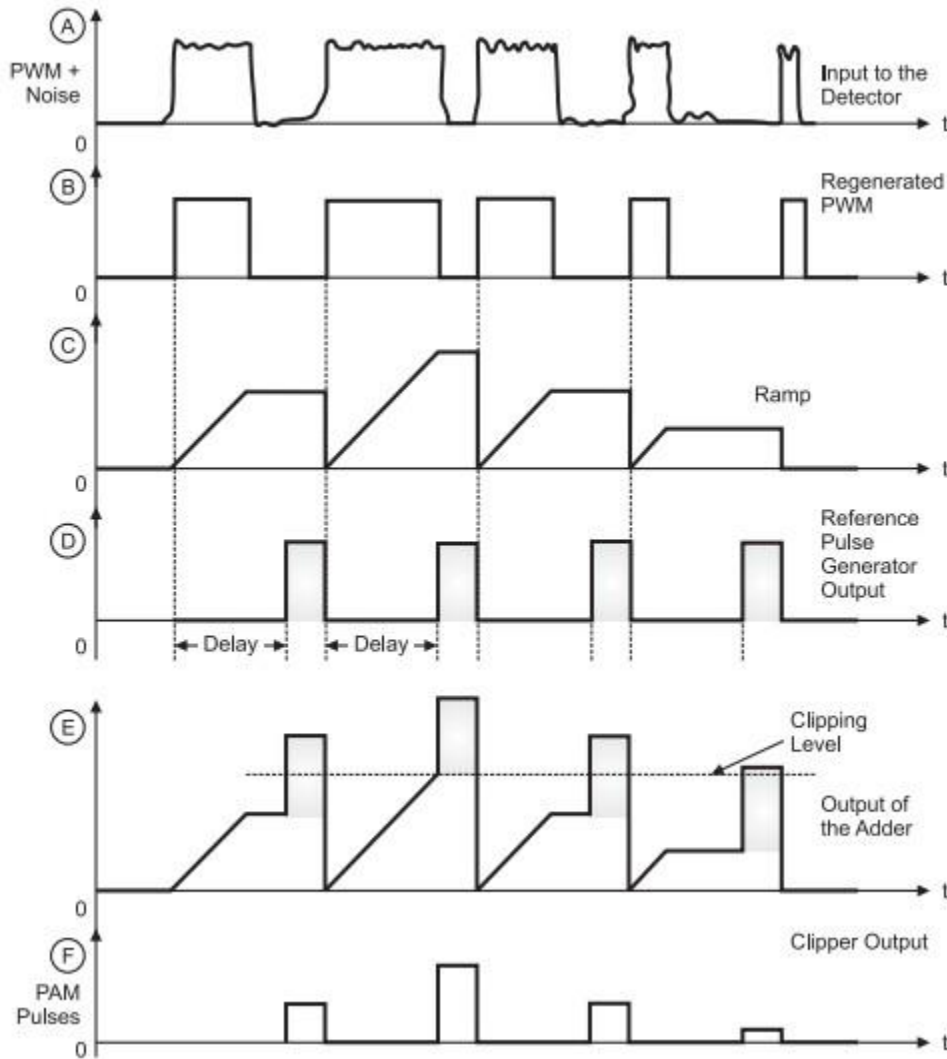

Figure.5.4.6 : Waveforms for PWM detection circuit

Diagram Source Brain Kart

Disadvantages of PWM

Due to the variable pulse width, the pulses have variable power contents. Hence, the transmission must be powerful enough to handle the maximum width, pulse, though the average power transmitted can be as low as 50% of this maximum power. In order to avoid any waveform distortion, the bandwidth required for the PWM communication is large as compared to bandwidth of PAM.