

**2.3. SHEAR FORCE AND BENDING MOMENT DIAGRAM FOR A SIMPLY SUPPORTED BEAM WITH CENTRAL POINT LOAD**

Consider a beam AB of length L simply supported at the ends A and B and carrying a point load W at its middle point C.

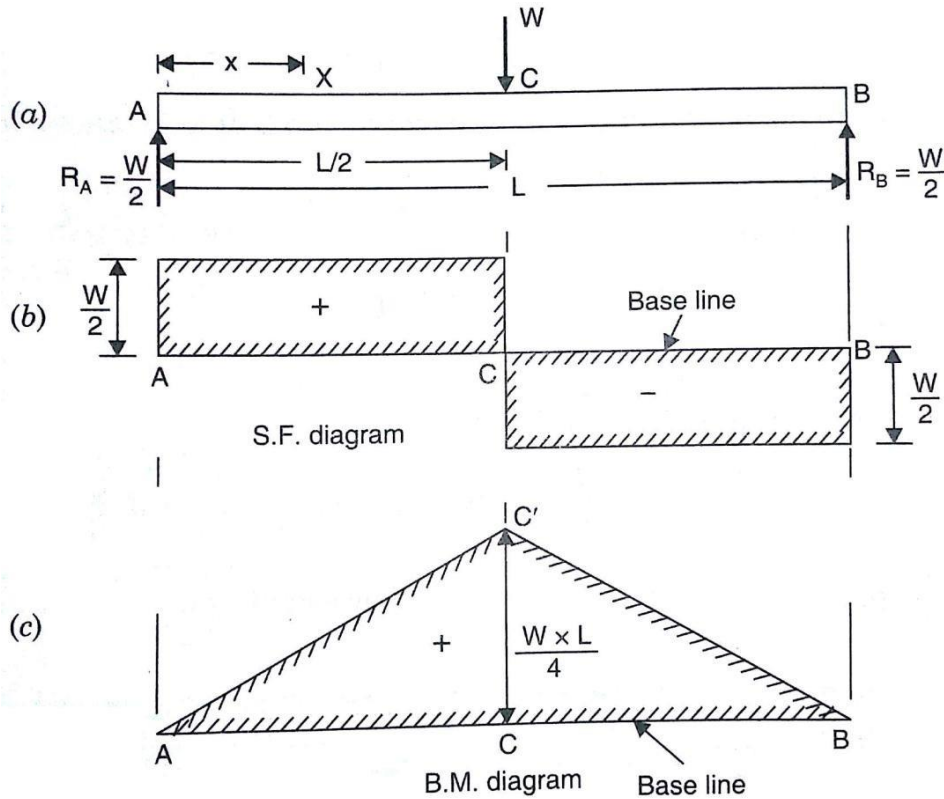

First to find the reaction force at A and B as  $R_A$  and  $R_B$  by the two steps are followed.

Step 1: Take moment about A = 0  $\gg R_B \times L - W \times \frac{L}{2} = 0 \gg R_B = \frac{W}{2}$

Step 2: Sum of upward force = Sum of downward force  $\gg R_A + R_B = W$

then  $R_A = W - R_B \gg R_A = W - \frac{W}{2} = \frac{W}{2}$

Hence  $R_A = R_B = \frac{W}{2}$

Take a section X at a distance x from the end B between B and C. Here we have consider the right portion of the beam section.

Let  $F_x$  = Shear force at X and  $M_x$  = Bending moment at X

**Shear Force Calculation:**

The shear force at X will be equal to the resultant force acting on the right of the portion of the section. But the resultant force on the right portion is  $R_B = \frac{W}{2}$  acting upward.

Hence the shear force at X is positive and its magnitude is  $\frac{W}{2}$ .

∴ Shear force at X,  $= +\frac{W}{2}$

Hence the shear force between B and C is constant and equal to  $+\frac{W}{2}$

Now consider any section X between C and A at a distance  $x$  from end B. The resultant force on the right portion will be,

∴ Shear force at X between B and C,  $= +\frac{W}{2} - W = -\frac{W}{2}$

At the section C the shear force is same as  $-\frac{W}{2}$

### Shear Force Diagram:

When the point load acting on the beam is indicated in Shear force diagram as a *vertical line*. The shear force diagram shown in fig.

### Bending moment Calculation:

The bending moment at any section between B and C at a distance  $x$  from the end B, is given by

The bending moment will be positive as for the right portion of the section, the moment of the load at  $x$  is anti-clockwise about the section.

The bending moment at the section X is given by

$$M_x = (\text{total load on right portion}) \times (\text{Distance of the load from X}) = R_B \times x \\ = +\frac{W \cdot x}{2}$$

$$\text{BM at B, when } x=0 \text{ hence } = +\frac{W \cdot 0}{2} = 0$$

$$\text{BM at C, when } x=L \text{ hence } = +\frac{W \cdot L}{2} = \frac{WL}{2}$$

From the above eqn. it is clear that B.M. at any section is proportional to the distance between B and C. This follows a *straight line law*.

The bending moment at any section between C and A at a distance  $x$  from the end B, is given by

$$\text{BM at X, at a distance } x = M = R_B \cdot x - W(x - \frac{L}{2}) = \frac{W \cdot x}{2} - W(x - \frac{L}{2})$$

$$M_x = \frac{WL}{2} - \frac{Wx}{2}$$

$$\text{BM at C, when } x = L \text{ hence } = \frac{WL}{2} - \frac{W}{2} \cdot \frac{L}{2} = \frac{WL}{4}$$

$$\text{BM at A, when } x = L \text{ hence } = \frac{WL}{2} - \frac{WL}{2} = 0$$

Hence bending moment at C is  $\frac{WL}{4}$  and it decreases to zero at A.

### Bending moment Diagram:

When point load acting on the beam is indicated in Bending Moment diagram as an *inclined line*. The Bending Moment diagram shown in fig.

**Problem 2.3.1:** A simply supported beam of length 6m, carries point load of 3kN and 6kN of 2m and 4m from the left end. Draw the SF and BM diagrams for the beam.

**Given Data:** shown in figure. **To**

**find:** SFD and BMD **Solution:**

**Find the reaction at A and B as  $R_A$  and  $R_B$**

**Step 1:** Take moment about A is equal to zero

$$R_B \times 6 - (6 \times 4) - (3 \times 2) = 0 \gg R_B \times 6 = (6 \times 4) + (3 \times 2) / 6 \gg R_B = 5 \text{ kN}$$

**Step 2:** Sum of upward force = Sum of downward force

$$R_A + R_B = 6 + 3 \gg R_A = 9 - R_B \gg R_A = 9 - 5 = 4 \text{ kN}$$

**Shear Force Calculation:** (Sum of vertical forces) SF at

$$B = - R_B = - 5 \text{ kN}$$

$$\text{SF at C} = -5 + 6 = +1 \text{ kN}$$

$$\text{SF at D} = -5 + 6 + 3 = +4 \text{ kN}$$

$$\text{SF at A} = -5 + 6 + 3 = +4 \text{ kN}$$

**Shear Force Diagram:**

Vertical downward point load are drawn as upward vertical line

Vertical upward reaction force are drawn as downward vertical line. No

load are drawn as horizontal line.

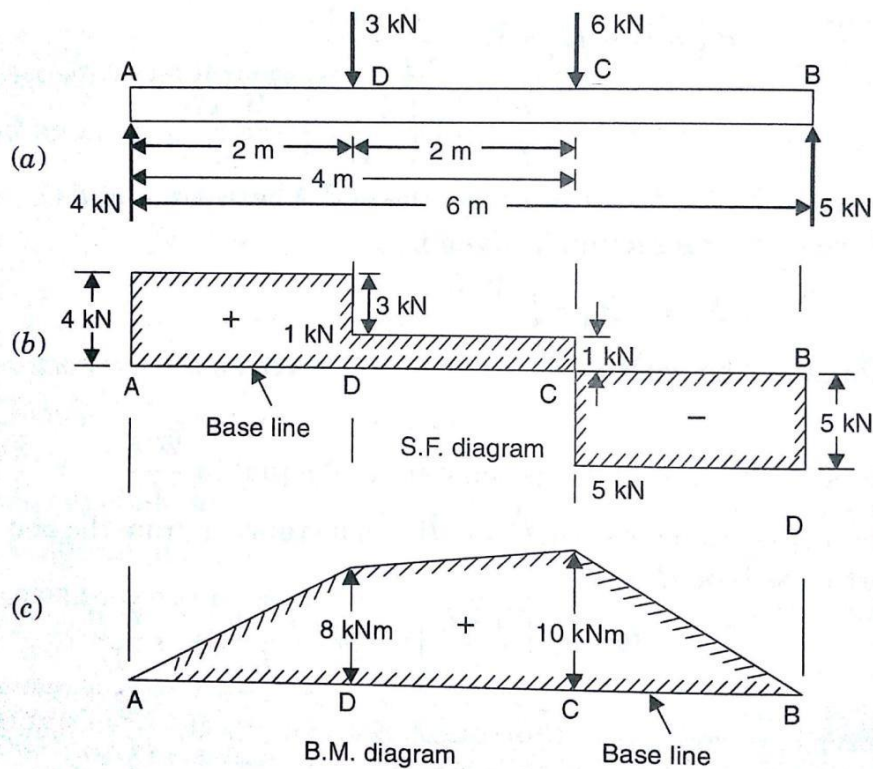

**Bending moment Calculation:** [Sum of (Vertical force  $\times$  Distance of load acting from required section)]

$$B_{\text{MatB}} = +(R_B \times 0) = 0 \text{ kNm}$$

$$B_{\text{MatC}} = +(5 \times 2) - (6 \times 0) = +10 \text{ kNm}$$

$$B_{\text{MatD}} = +(5 \times 4) - (6 \times 2) - (3 \times 0) = +8 \text{ kNm}$$

$$B_{\text{MatA}} = +(5 \times 6) - (6 \times 4) - (3 \times 2) = 0 \text{ kNm}$$

**Bending moment Diagram:**

Vertical downward point loads are drawn as inclined lines based on their sign.

**Result:** The SFD and BMD are drawn as shown in fig.

### 2.3.2. SHEAR FORCE AND BENDING MOMENT DIAGRAM FOR A SIMPLY SUPPORTED BEAM WITH UNIFORMLY DISTRIBUTED LOAD

Consider a beam AB of length  $L$  simply supported at the end A and carrying a uniformly distributed load of  $w$  per unit length over the entire length of the beam.

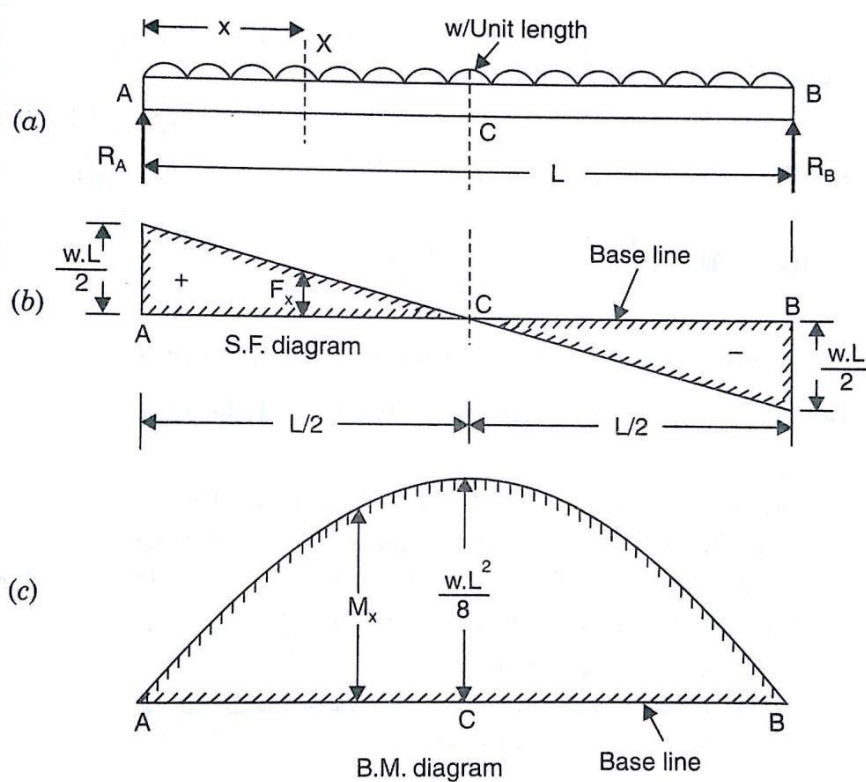

First to find the reaction force at A and B as  $R_A$  and  $R_B$  by the two steps are followed.

Step 1: Take moment about A = 0  $\gg R_B \times L - w \cdot L \times \frac{L}{2} = 0 \gg R_B = \frac{wL}{2}$

Step 2: Sum of upward force = Sum of downward force  $\gg R_A + R_B = w \cdot L$

$$\text{then } R_A = w \cdot L - R_B \gg R_A = w \cdot L - \frac{wL}{2} = \frac{wL}{2}$$

$$\text{Hence } R_A = R_B = \frac{wL}{2}$$

Take a section X at a distance  $x$  from the end B, between B and C. Here we have consider the right portion of the beam section.

Let  $F_x$  = Shear force at X and  $M_x$  = Bending moment at X

#### Shear Force Calculation:

The shear force at X will be equal to the resultant force acting on the right of the portion of the section. But the resultant force on the right portion is  $R_B = \frac{wL}{2}$  acting upward and downward UDL as  $w \cdot x$ .

$$\therefore \text{Shear force at X, } = -R_B + w \cdot x$$

$$F_x = -\frac{wL}{2} + w \cdot x$$

The above equations show that the shear force follows a straight line law.

$$\text{SF at B, when } x=0 \text{ hence } = -\frac{wL}{2} + w \cdot 0 = -\frac{wL}{2}$$

$$\text{SF at C, when } x = \frac{L}{2} \text{ hence } = -\frac{wL}{2} + \frac{wL}{2} = 0$$

$$\text{SF at A, when } x=L \text{ hence } = -\frac{wL}{2} + wL = +\frac{wL}{2}$$

### Shear Force Diagram:

When a UDL acting on the beam is indicated in Shear force diagram as an *inclined line*. The shear force diagram shown in fig.

### Bending moment Calculation:

The bending moment at any section between B and C at a distance  $x$  from the end B, is given by

The bending moment will be positive as for the right portion of the section, the moment of the load at  $x$  is anti-clockwise about the section.

The bending moment at the section X is given by

$$M_x = (\text{total load on right portion}) \times (\text{Distance of the load from X})$$

$$= +R_B x - w \cdot x \cdot \frac{x}{2} = \frac{wL}{2} \cdot x - \frac{w \cdot x^2}{2}$$

From the above eqn. it is clear that B.M. at any section is proportional to the square of the distance from the free end. This follows a parabolic law.

$$\text{BM at B, when } x = 0 \text{ hence } = +\frac{wL}{2} \cdot 0 - \frac{w \cdot 0^2}{2} = 0$$

$$\text{BM at C, when } x = \frac{L}{2} \text{ hence } = +\frac{wL}{2} \cdot \frac{L}{2} - \frac{w \cdot \left(\frac{L}{2}\right)^2}{2} = +\frac{wL^2}{8}$$

$$\text{BM at A, when } x = L \text{ hence } = +\frac{wL}{2} \cdot L - \frac{w \cdot L^2}{2} = 0$$

The maximum B.M. occurs at the centre of the beam, where S.F. becomes zero after changing its sign.

### Bending moment Diagram:

When a UDL acting on the beam is indicated in Bending Moment diagram as a *parabolic curved line*. The Bending Moment diagram shown in fig.

**Problem 2.3.3:** A beam of 8m span simply supported at its end carries loads of 2kN and 5kN at a distance of 3m and 6m from right support respectively. In addition the beam carries a

UDL of 4kN/m for its entire length. Draw the shear force and bending moment diagram. Also find the maximum bending moment.

**Given Data:** shown in figure.

**To find:** SFD and BMD, Max. BM

**Solution:**

**Find the reaction at A and B as  $R_A$  and  $R_B$**

**Step 1:** Take moment about A is equal to zero

For UDL, it will be converted into point load as (Point load = UDL × load acting distance) and the converted point load acting at its middle means divided by 2

$$R_B \times 8 - (2 \times 5) - (5 \times 2) - [(4 \times 8) \times \frac{8}{2}] = 0$$

$$R_B \times 8 = (2 \times 5) + (5 \times 2) + [(4 \times 8) \times \frac{8}{2}] \quad \gg R_B = 18.5 \text{ kN}$$

**Step 2:** Sum of upward force = Sum of downward force

$$R_A + R_B = 2 + 5 + (4 \times 8) \quad \gg R_A = 39 - R_B \gg R_A = 39 - 18.5 = 20.5 \text{ kN}$$

**Shear Force Calculation:** (Sum of vertical forces)

For UDL, it will be converted into point load as (Point load = UDL × load acting distance) and the converted point load acting at its middle means divided by 2

$$\text{SF at B} = -R_B = -18.5 \text{ kN}$$

When point load and UDL acting at a particular point, first we have not consider Point Load and next consider point load to find shear force

$$\text{SF at C} = -18.5 + (4 \times 3) = -6.5 \text{ kN} \quad (\text{Without consider PL})$$

$$\text{SF at C} = -18.5 + 2 + (4 \times 3) = -4.5 \text{ kN} \quad (\text{With consider PL})$$

$$\text{at D} = -18.5 + 2 + (4 \times 6) = +4.5 \text{ kN} \quad (\text{Without consider PL})$$

$$\text{SF at D} = -18.5 + 2 + 5 + (4 \times 6) = +12.5 \text{ kN} \quad (\text{With consider PL})$$

$$SF_{at A} = -18.5 + 2 + 5 + (4 \times 8) = +20.5 \text{ kN}$$

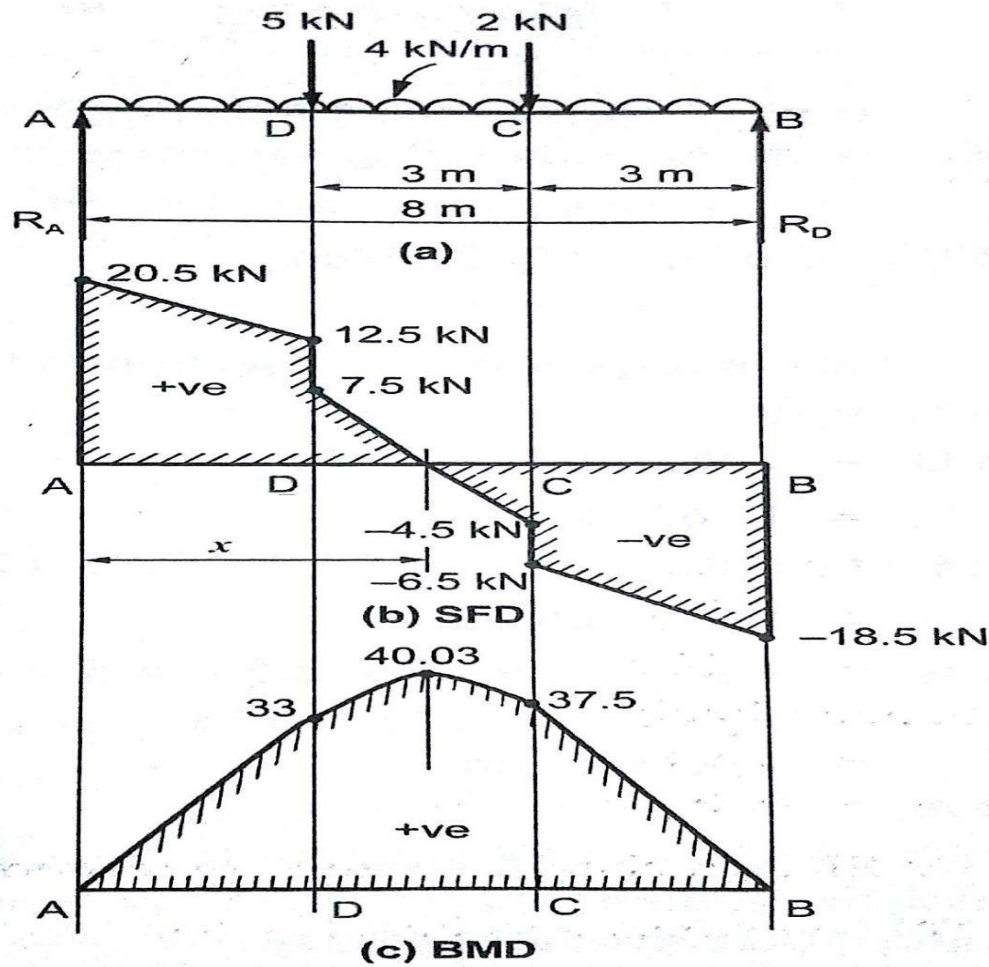

### Shear Force Diagram:

Vertical downward point load are drawn as vertical line based on sign

Vertical downward UDL are drawn as inclined line based on sign

**Bending moment Calculation:** [Sum of (Vertical force  $\times$  Distance of load acting from required section)]

For UDL, it will convert into point load and that PL act at its middle. BM at B

$$= +(18.5 \times 0) = 0 \text{ kNm}$$

$$BM_{at C} = +(18.5 \times 3) - (2 \times 0) - [(4 \times 3) \times \frac{3^2}{2}] = +37.5 \text{ kNm}$$

$$BM_{at D} = +(18.5 \times 6) - (2 \times 3) - (5 \times 0) - [(4 \times 6) \times \frac{6^2}{2}] = +33 \text{ kNm}$$

$$BM_{at A} = +(18.5 \times 8) - (2 \times 5) - (5 \times 2) - [(4 \times 8) \times \frac{8^2}{2}] = 0 \text{ kNm}$$

### Bending moment Diagram:

Vertical downward PL are drawn as inclined line and UDL are drawn as parabolic curved line based on their sign.

### Calculate Maximum Bending Moment:



### Method 1

The maximum BM will occur where the shear force becomes zero. Let us take a point X at a distance of  $x$  from B where SF become zero is shown in fig.

$$SF \text{ at } X = -R_B + 2 + (4 \times x) = 0 \gg -18.5 + 2 + 4 \cdot x = 0 \gg x = 4.125 \text{ m}$$

### Method 2

$$\begin{aligned} \text{Distance } x &= \text{distance BC} + \left( \frac{\text{Vertical Height of particular Triangle}}{\text{UDL}} \right) \\ &= 3 + \left( \frac{4.5}{4} \right) \\ &= 3 + 1.125 = 4.125 \text{ m} \end{aligned}$$

$$BM \text{ at } X = +(18.5 \times 4.125) - [2 \times (4.125 - 3)] - \left[ \frac{(4 \times 4.125)^2}{2} \right] = 40.03 \text{ kNm}$$

### Result:

The SFD and BMD are drawn as shown in fig.

Maximum BM = **40.03 kNm** acting at a distance of **4.125 m** from right support.

## 2.3.4. SHEAR FORCE AND BENDING MOMENT DIAGRAM FOR A SIMPLY SUPPORTED BEAM WITH UNIFORMLY VARYING LOAD

### Case 1: UVL from zero at each end to $w$ per unit length at the centre

A beam of length  $L$  simply supported at the ends A and B and carrying a uniformly varying load from zero at each end to  $w$  per unit length at the centre. The reactions at the supports will be equal and their magnitude will be half the total load on the entire length as the load is symmetrical on the beam.

Total load on the beam = Area of triangle ABC

$$\begin{aligned} \therefore \text{Reaction forces } R_A = R_B &= \frac{1}{2} \times \text{AB} \times \text{CO} = \frac{1}{2} \times L \times \frac{w}{2} = \frac{w \cdot L}{4} \end{aligned}$$

Take a section X at a distance  $x$  from the end B, between B and C. Here we have considered the right portion of the beam section.

Let  $F_x$  = Shear force at X and  $M_x$  = Bending moment at X

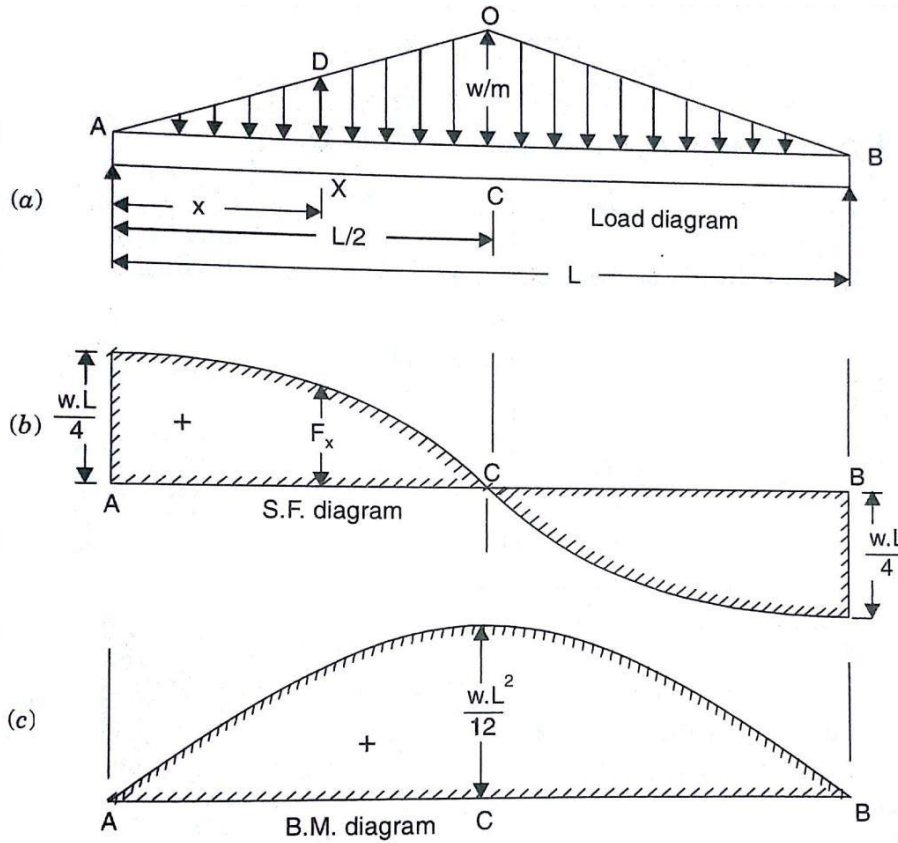

**Shear Force Calculation:**

Let us first find the rate of loading at the section X. The rate of loading is zero at B and is 'w' per meter run at C. This means that the rate of loading for a length L is w per unit length.

Hence the rate of loading for a length of x =  $w \cdot \frac{x}{L}$  per unit length.  $\Rightarrow \frac{DX}{\frac{L}{2}} = 2w \cdot \frac{x}{L}$

$$\left[ \frac{BX}{\frac{L}{2}} = \frac{DX}{w} \Rightarrow DX = \frac{x \cdot w}{\frac{L}{2}} = \frac{2 \cdot w \cdot x}{L} \right]$$

Now load on the length AX of the beam = Area of load diagram BXD

$$= \frac{1}{2} \times \frac{L}{2} \times \frac{DX}{L} = \frac{1}{2} \times \frac{L}{2} \times \frac{2w}{L} \cdot \frac{x}{L} = \frac{w}{L} \cdot \frac{x^2}{2}$$

This load is acting at a distance of  $\frac{x}{3}$  from X or  $\frac{2x}{3}$  from B.

The shear force at the section X at a distance x from free end is given by

$$F_x = -R_B + \text{load on the length BX}$$

$$= -\frac{wL}{4} + \frac{w}{L} \cdot \frac{x^2}{2}$$

The above eqn. shows that the SF varies according to the parabolic law between B and

C.

$$\text{SF at B, when } x=0 \text{ hence } = -w.L + \frac{w}{4} \cdot 0^2 = -\frac{w.L}{4}$$

$$\text{SF at C, when } x=L \text{ hence } = -\frac{w.L}{4} + \frac{w}{4} \left(\frac{L}{2}\right)^2 = -\frac{w.L}{4} + \frac{w.L}{4} = 0$$

$$\text{SF at A, when } x=L \text{ hence } = +R_A = +\frac{w.L}{4}$$

### Shear Force Diagram:

When an UVL acting on the beam is indicated in Shear force diagram as an *parabolic curve line*. The shear force diagram shown in fig.

### Bending moment Calculation:

The bending moment at both ends become zero.

The bending moment will be positive as for the right portion of the section, the moment of the load at  $x$  is anti-clockwise about the section.

The bending moment at  $X$  at a distance of  $x$  from B is given by,

$$M_x = +R_B \cdot x - \text{load of length } AX \cdot \frac{x}{3}$$

$$= \frac{w.L}{4} \cdot x - \frac{w}{L} \cdot x^2 \cdot \frac{x}{3} = \frac{wL}{4} \cdot x - \frac{wx^3}{3L}$$

From the above eqn. it is clear that B.M. at any section is proportional to the cube of the distance from the free end. This follows a cubic law.

$$\text{BM at B, when } x=0 \text{ hence } = +\frac{wL}{4} \cdot 0 - \frac{w}{3L} \cdot 0^3 = 0$$

$$\text{BM at C, when } x = \frac{L}{2} \text{ hence } = +\frac{w.L}{4} \cdot \frac{L}{2} - \frac{w}{3L} \cdot \left(\frac{L}{2}\right)^3 = +\frac{wL^2}{8} - \frac{wL^2}{24} = +\frac{wL^2}{12}$$

The maximum B.M. occurs at the centre of the beam, where S.F. becomes zero after changing its sign.

$$\therefore \text{Maximum B.M. is at C, } = \frac{wL^2}{12}$$

### Bending moment Diagram:

When an UVL acting on the beam is indicated in Bending Moment diagram as a *cubic curved line*. The Bending Moment diagram shown in fig.

**Problem 2.3.5:** The intensity of loading on a simply supported beam of 4m span increases gradually from 30 kN/m run at one end to 130 kN/m run at the other end. Draw the shear force and Bending Moment diagram. Also find the maximum BM.

### Given Data:

shown in figure.

**To find:**

SFD and BMD, Max. BM

**Solution:**

The load will be considered as (i) UDL of 30 kN/m run throughout the span. (ii)

UVL which is zero at the right end B and increases to 100 kN/m run at left end A.

**Find the reaction at A and B as  $R_A$  and  $R_B$**

**Step 1:** Take moment about A is equal to zero

For UDL, it will be converted into point load as (Point load = UDL × load acting distance) and the converted point load acting at its middle means divided by 2.

For UVL, it will be converted into point load as (Point load = Area of triangle =  $\frac{1}{2} \times$

UVL × load acting distance) and the converted point load acting distance at its  $\frac{1}{3}$  from the higher load end.

$$R_B \times 4 - [(30 \times 4) \times 2] - [(\frac{1}{2} \times 4 \times 100) \times \frac{1}{3}] = 0$$

$$R_B \times 4 = [(30 \times 4) \times 2] + [(\frac{1}{2} \times 4 \times 100) \times \frac{1}{3}] \quad \gg R_B = 126.67 \text{ kN}$$

**Step 2:** Sum of upward force = Sum of downward force

$$R_A + R_B = (30 \times 4) + (\frac{1}{2} \times 4 \times 100) \quad \gg R_A = 320 - R_B$$

$$\gg R_A = 320 - 126.67 = 193.33 \text{ kN}$$

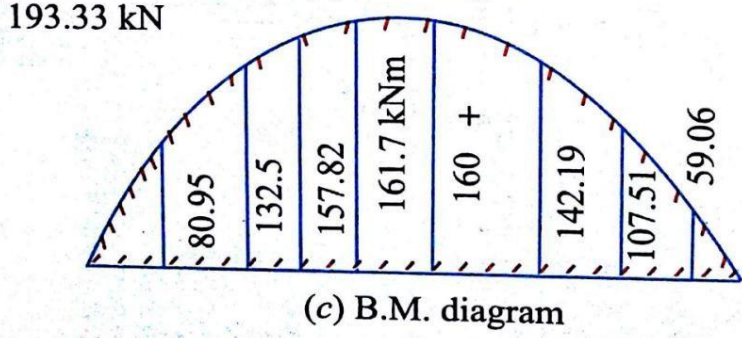
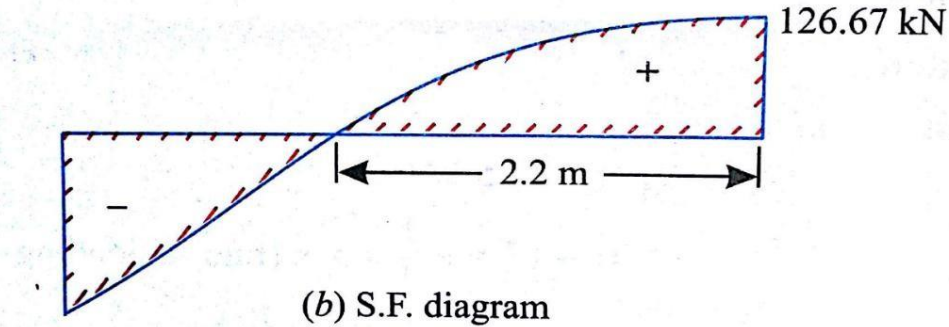
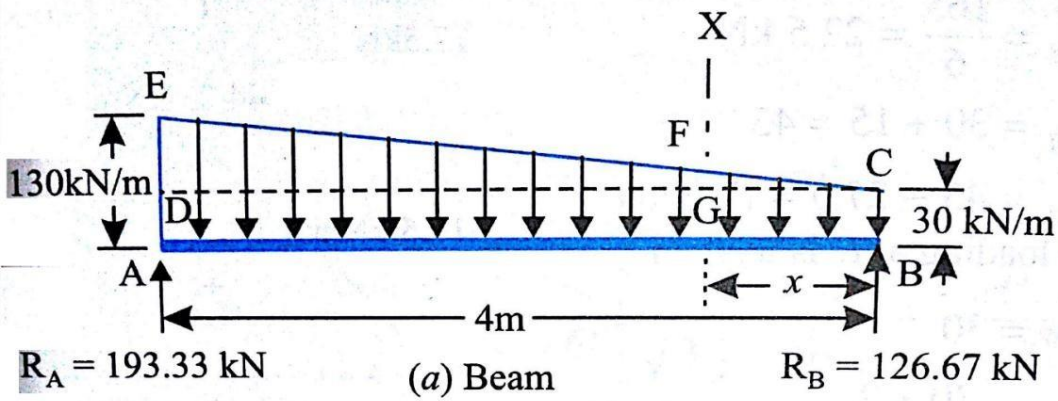

**Shear Force Calculation:** (Sum of vertical forces) SF at

$$B = -R_B = -126.67 \text{ kN}$$

$$\text{SF at A} = -126.67 + (30 \times 4) + \left(-\frac{1}{2} \times 4 \times 100\right) = +193.33 \text{ kN}$$

**Shear Force Diagram:**

Vertical upward reaction load are drawn as vertical line based on sign

Downward UVL are drawn as parabolic curved line based on sign

**Bending moment Calculation:** [Sum of (Vertical force  $\times$  Distance of load acting from required section)]

B.M. at both end B and A become Zero.

**Bending moment Diagram:**

Vertical downward PL are drawn as inclined line and UDL are drawn as parabolic curved line based on their sign.

**Calculate Maximum Bending Moment:**

The maximum BM will occur where the shear force becomes zero. Let us take a point X at a distance of  $x$  from B where SF become zero is shown in fig.

$$\text{SF at X} = -R_B + (30x) + \left(1 - \frac{x}{2}\right) \times 25x = 0$$

The rate of loading FG is calculate by the similar  $\Delta^{le}CDE$  and  $CFG$

$$\frac{FG}{DE} = \frac{CG}{CD} \quad \Rightarrow FG = \frac{CG \times DE}{CD} \quad \Rightarrow FG = \frac{x \times 100}{4} \quad \Rightarrow FG = 25x$$

Substitute the FG value in shear force at X which gives

$$= -126.67 + 30x + \left(1 - \frac{x}{2}\right) \times 25x = 0$$

$$12.5x^2 + 30x - 126.67 = 0$$

$$\text{Then } x = \frac{-30 \pm \sqrt{30^2 - 4 \times 12.5 \times -126.67}}{2 \times 12.5} = 2.2 \text{ m (neglect the -ve value)}$$

$$\begin{aligned} \text{Then BM at X} &= + (126.67 \times 2.2) - [(30 \times 2.2) \times 2.2] - \left[ \frac{1 \times 2.2 \times 100}{2} \times \frac{2.2^2}{3} \right] \\ &= 161.7 \text{ kNm} \end{aligned}$$

**Result:** The SFD and BMD are drawn as shown in fig.

Maximum BM = **161.7 kNm** acting at a distance of **2.2 m** from right support.