



ROHINI COLLEGE OF ENGINEERING & TECHNOLOGY

Near Anjugramam Junction, Kanyakumari Main Road, Palkulam, Variyoor P.O - 629401
Kanyakumari Dist, Tamilnadu., E-mail : admissions@rcet.org.in, Website : www.rcet.org.in

DEPARTMENT OF MECHANICAL ENGINEERING



ME3491 THEORY OF MACHINES

COURSE MATERIAL

CHAPTER 2 DYNAMIC FORCE ANALYSIS

When the inertia forces are considered in the analysis of the mechanism, the analysis is known as dynamic force analysis. Now applying D'Alembert principle one may reduce a dynamic system into an equivalent static system and use the techniques used in static force analysis to study the system.

Inertia force and couple

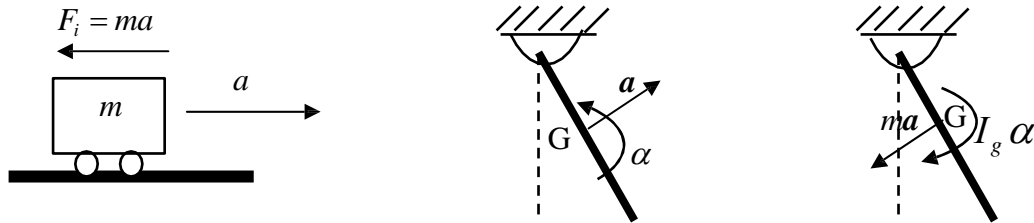

Figure 1: Illustration of inertia force (i) a translating body (ii) a compound pendulum, (iii) inertia force and couple on compound pendulum.

Consider a body of mass m moving with acceleration a as shown in figure 1(i). According to D'Alembert Principle, the body can be brought to equilibrium position by applying a force equal to $F_i = ma$ and in a direction opposite to the direction of acceleration. Figure 1 (ii) shows a compound pendulum of mass m , moment of inertia I_g about center of mass G while rotating at its center of mass has a linear acceleration of a and angular acceleration of α . Figure 1(iii) shows the inertia force and couple acting on the pendulum.

Equivalent off-set Inertia force

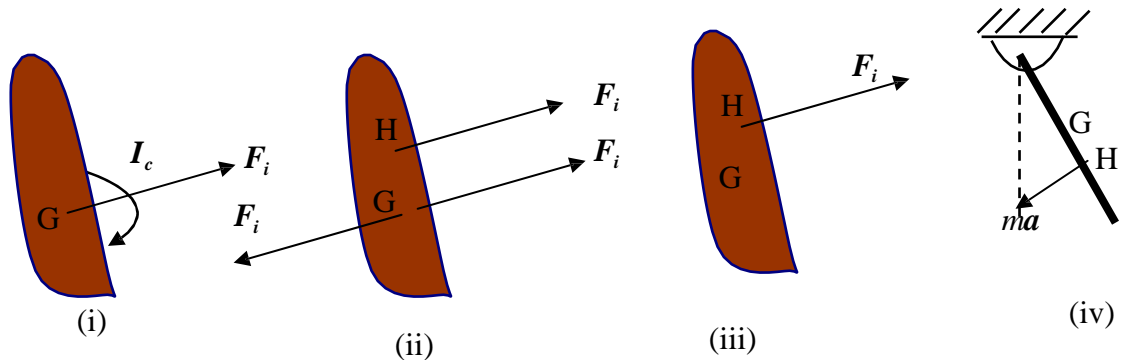

Figure 2: (i) Illustration of equivalent off-set inertia force

Figure 2(i) shows a body with inertia force F_i and inertia couple I_c . The couple can be replaced by two parallel forces (equal in magnitude and opposite in direction) acting at G and H respectively as shown in Figure 2(ii). If we consider their magnitude of these forces same as that of inertia force, then the equal

and opposite forces at point G will cancel each other and the resulting force will be a force at H which is in the same direction as inertia force. If h is the minimum distance between the force at G and H, then

$$h = \frac{I_c}{F_i}$$

where I_c and F_i are magnitude of I_c and F_i respectively. This force acting at H is known as equivalent offset inertia force. For the compound pendulum shown in Figure 1(iii), the equivalent offset inertia force is shown in Figure 2(iii).

Dynamic force analysis of four bar mechanism

Let us study the four bar mechanism where m_2, m_3 and m_4 are mass of link 2,3 and 4 respectively. We have to find the torque required at link 2 for dynamic equilibrium when an external force F_4 acts on link 4 as shown in figure 3. Now for dynamic force analysis the following steps may be followed.

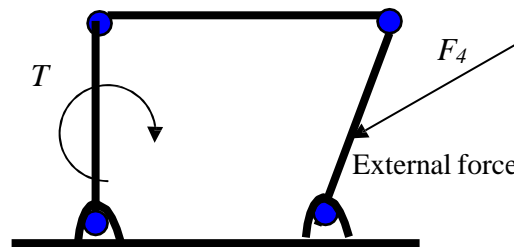

Figure 1: Four bar mechanism showing external and constraint forces

- Draw the acceleration diagram or use any analytical method to determine acceleration
- Determine angular acceleration of link 2,3 and 4.
- Determine linear acceleration of center of mass (a_{gi} $i = 2, 3, 4$) of link 2 3 and 4 .
- The magnitude of inertia force of link i ($i = 2, 3$ or 4) can be determined by multiplying mass of link i with the corresponding acceleration of the center of mass.
- The direction of the inertia force is opposite to the direction of the acceleration.
- Determine the magnitude of inertia couple which is equal to $I_i \alpha_i$
- The direction of the inertia couple is opposite to that of angular acceleration.
- Replace the inertia force and couple by the equivalent offset inertia force for each link.
- Treat these offset inertia force as external force and follow the procedure for static force analysis.
- One may use either super-position principle or principle of virtual work to find the required torque for equilibrium.

$$F_{gi} = -m_i a_{gi}$$

Dynamic Force Analysis of a Four bar Mechanism using Matrix Method

In the four bar mechanism shown in Figure 1, Link 1 is the ground link (sometimes called the frame or fixed link), and is assumed to be motionless. Links 2 and 4 each rotate relative to the ground link about fixed pivots (A and D). Link 3 is called the coupler link, and is the only link that can trace paths of arbitrary shape (because it is not rotating about a fixed pivot). Usually one of the "grounded links" (link 2 or 4) serves as the input link, which is the link which may either be turned by hand, or perhaps driven by an electric motor or a hydraulic or pneumatic cylinder. If link 2 is the input link, then link 4 is called the follower link, because its rotation merely follows the motion as determined by the input and coupler link motion. If link 2 is the input link and its possible range of motion is unlimited, it is called a crank, and the linkage is called a crank-rocker. Crank-rockers are very useful because the input link can be rotated continuously while a point on its coupler traces a closed complex curve.

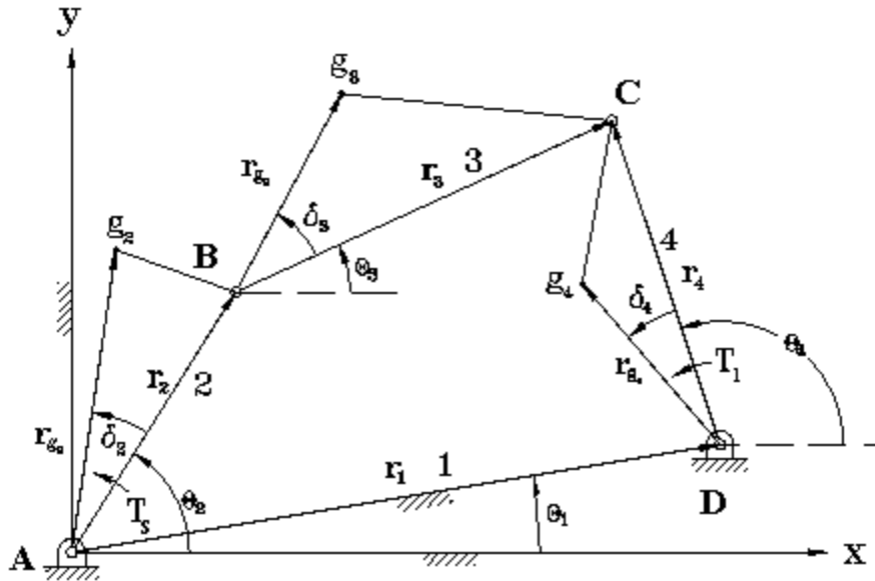

Fig.1. A Simple four-bar linkage.

The dynamic force analysis problem was solved using the matrix method by reducing it to one requiring static analysis. For this purpose, D'Alembert's Principle which states that the inertia forces and couples, and the external forces and torques on the body together give statically equilibrium, was considered. The inertia forces F_{gi} 's and inertia moments T_{gi} 's are given by,

$$F_{gi} = -m_i a_{gi} \quad (1)$$

$$T_{gi} = -I_i \alpha_{gi} \quad (2)$$

where, m_i is the mass of the link i , I_i is the moment of inertia about an axis passing through the centre of mass g_i and perpendicular to plane of rotation of the link i , a_{g_i} and α_{g_i} are the acceleration and angular acceleration of the centre of mass of the i^{th} link respectively.

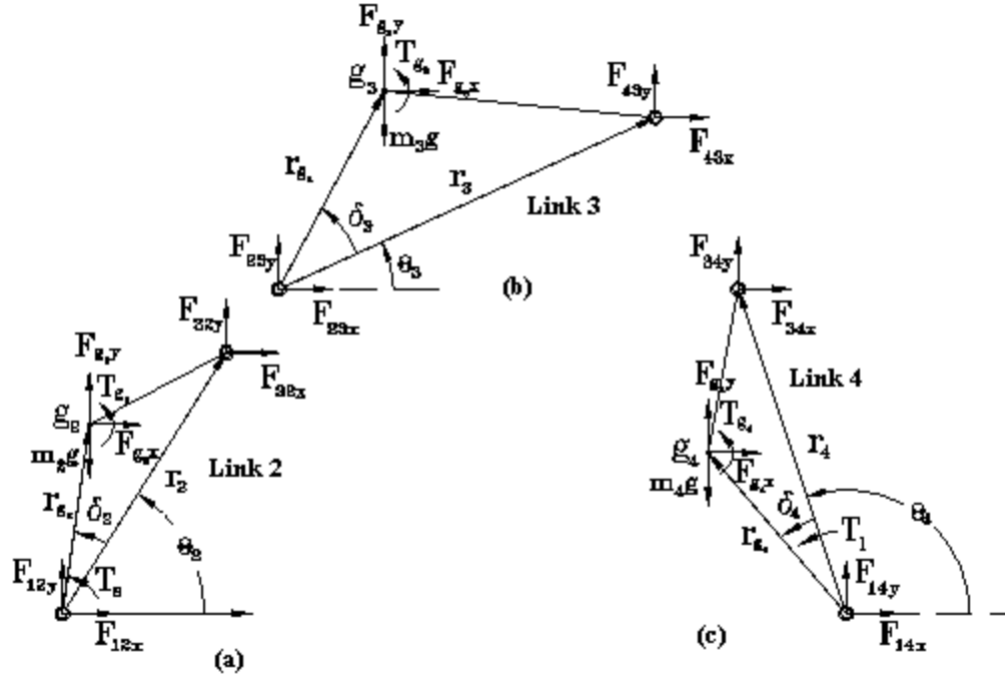

Fig.2. The Free-body diagrams of (a) Link 2(crank/input link) (b) Link 3(coupler) (c) Link 4(follower link)

Given position, velocity, acceleration, and inertia properties such as mass and mass moment of inertia for each moving link of a four-bar linkage, force analysis for the linkage can be performed.

From the free body diagrams (Fig.2.) three static equilibrium equations, in terms of forces in the X and Y directions and moment about the center of gravity of the link, can be written for each link. For link 2, we get

$$F_{12x} + F_{32x} + F_{g2x} = 0 \quad (3)$$

$$-m_2g + F_{12y} + F_{32y} + F_{g2y} = 0 \quad (4)$$

$$T_s - r_{g2}F_{12} + (r_2 - r_{g2})F_{32} + T_{g2} = 0 \quad (5)$$

where, $r_{g2} = r_{g2} \exp(i(\theta_2 + \delta_2))$ is the position vector from joint A to the center of gravity of link 2. F_{12} and F_{32} are the joint forces acting on link 2. F_{g2} and T_{g2} are the inertia force and inertia moment of link 2. m_2 is the mass of link 2 and T_s is the driving torque. Similarly for link 3, we get

$$F_{23x} + F_{43x} + F_{g3x} = 0 \quad (6)$$

$$-m_{3g} + F_{23y} + F_{43y} + F_{g3y} = 0 \quad (7)$$

$$-r_{g3}F_{23} + (r_3 - r_{g3})F_{43} + T_{g3} = 0 \quad (8)$$

where, $r_{g3} = r_{g3} \exp(i(\theta_3 + \delta_3))$ is the position vector from joint B to the center of gravity of link 3. F_{23} and F_{43} are the joint forces acting on link 3. F_{g3} and T_{g3} are the inertia force and inertia moment of link 3. m_3 is the mass of link 3. Similarly for link 4, we get

$$F_{34x} + F_{14x} + F_{g4x} = 0 \quad (9)$$

$$-m_{4g} + F_{34y} + F_{14y} + F_{g4y} = 0 \quad (10)$$

$$-r_{g4}F_{14} + (r_4 - r_{g4})F_{34} + T_{g4} + T_1 = 0 \quad (11)$$

where, $r_{g4} = r_{g4} \exp(i(\theta_4 + \delta_4))$ is the position vector from joint D to the center of gravity of link 4. F_{14} and F_{34} are the joint forces acting on link 4. F_{g4} and T_{g4} are the inertia force and inertia moment of link 4. m_4 is the mass of link 4 and T_1 is the torque of external load.

The equations (5), (8), and (11) can be expressed as,

$$\begin{aligned} T_s - r_{g2} \cos(\theta_2 + \delta_2)F_{12y} + r_{g2} \sin(\theta_2 + \delta_2)F_{12x} + (r_2 \cos \theta_2 - r_{g2} \cos(\theta_2 + \delta_2))F_{32y} \\ - (r_2 \sin \theta_2 - r_{g2} \cos(\theta_2 + \delta_2))F_{32x} + T_{g2} = 0 \end{aligned} \quad (12)$$

$$\begin{aligned} -r_{g3} \cos(\theta_3 + \delta_3)F_{23y} + r_{g3} \sin(\theta_3 + \delta_3)F_{23x} + (r_3 \cos \theta_3 - r_{g3} \cos(\theta_3 + \delta_3))F_{43y} \\ - (r_3 \sin \theta_3 - r_{g3} \cos(\theta_3 + \delta_3))F_{43x} + T_{g3} = 0 \end{aligned} \quad (13)$$

$$\begin{aligned} -r_{g4} \cos(\theta_4 + \delta_4)F_{14y} + r_{g4} \sin(\theta_4 + \delta_4)F_{14x} + (r_4 \cos \theta_4 - r_{g4} \cos(\theta_4 + \delta_4))F_{34y} \\ - (r_4 \sin \theta_4 - r_{g4} \cos(\theta_4 + \delta_4))F_{34x} + T_{g4} = 0 \end{aligned} \quad (14)$$

Here, it was taken into account that $F_{ijx} = -F_{jix}$ and $F_{ijy} = -F_{jiy}$. Thus the equations (3 -11) can be written as nine linear equations in terms of nine unknowns. They can be expressed in a symbolic form

$$Ax = b \quad (15)$$

where, x = the transpose of $(F_{12x}, F_{12y}, F_{23x}, F_{23y}, F_{34x}, F_{34y}, F_{14x}, F_{14y}, T_s)$ and is a vector consisting of the unknown forces and input torque, b = the transpose of $(F_{g2x}, F_{g2y} - m_{2g}, T_{g2}, F_{g3x}, F_{g3y} - m_{3g}, T_{g3}, F_{g4x} - m_{4g}, T_{g4} + T_1)$ and is a vector that contains external load plus inertia forces and inertia torques. And the matrix 'A' which is a 9x9 matrix, is found to be

1	0	-1	0	0	0	0	0	0
0	1	0	-1	0	0	0	0	0
$r_{g2} \sin(\theta_2 + \delta_2)$	$-r_{g2} \cos(\theta_2 + \delta_2)$	$r_2 \sin \theta_2$ $-r_{g2} \cos(\theta_2 + \delta_2)$	$-r_2 \cos \theta_2$ $+r_{g2} \cos(\theta_2 + \delta_2)$	0	0	0	0	1
0	0	1	0	-1	0	0	0	0
0	0	0	1	0	-1	0	0	0
0	0	$r_{g3} \sin(\theta_3 + \delta_3)$	$-r_{g3} \cos(\theta_3 + \delta_3)$	$r_3 \sin \theta_3$ $-r_{g3} \cos(\theta_3 + \delta_3)$	$-r_3 \cos \theta_3$ $+r_{g3} \cos(\theta_3 + \delta_3)$	0	0	0
0	0	0	0	1	0	1	0	0
0	0	0	0	0	1	0	1	0
0	0	0	0	$-r_4 \sin \theta_4$ $+r_{g4} \cos(\theta_4 + \delta_4)$	$r_4 \cos \theta_4$ $+r_{g3} \cos(\theta_4 + \delta_4)$	$r_{g4} \sin(\theta_4 + \delta_4)$	$-r_{g4} \cos(\theta_4 + \delta_4)$	0

Solution procedure

A large number of inputs are required from the user, viz. link lengths of the four links, their masses, radius of gyration and departures of the centre of mass from the link positions (i.e. angle δ), input angle, initial angular velocity, angular acceleration and the external load torque. The procedure followed for solving the dynamic force analysis using the above formulated matrix method is as follows:

1. Once the inputs were taken, the link lengths were checked for feasibility.
2. When found to be feasible, the other angles (θ) were computed. It was found that two sets of solutions/orientations are possible.
3. Angular velocities and accelerations were calculated for both the possible orientations, which were used in the calculation of the inertia forces and couples.
4. After this the matrices 'A' and 'b' were computed. Similarly, matrices 'C' and 'd' were computed for the second orientation.
5. The solution sets X and Y { = the transpose of $(F_{12x}, F_{12y}, F_{23x}, F_{23y}, F_{34x}, F_{34y}, F_{14x}, F_{14y}, T_s)$ }, vectors consisting of the unknown forces and input torque were obtained by the following formulae,

$$X = A^{-1}b \quad (16)$$

$$Y = C^{-1}d \quad (17)$$

The MATLAB code generated for the simulation of the above problem is shown below.
 -(Code developed by Prithish Ranjan Parida(02010334), as part of assignment in ME308)

```
%DYNAMIC FORCE ANALYSIS OF FOUR-BAR MECHANISM
%TAKING INPUTS FROM THE USER FOR THE FOUR-BAR MECHANISM
a = input('enter the length of the link AB : ');
b = input('enter the length of the link BC : ');
c = input('enter the length of the link CD : ');
d = input('enter the length of the link DA(fixed link) : ');
```

```

ma = input('enter the mass of link AB : ');
mb = input('enter the mass of link BC : ');
mc = input('enter the mass of link CD : ');
ka = input('enter the radius of gyration of link AB : ');
kb = input('enter the radius of gyration of link BC : ');
kc = input('enter the radius of gyration of link CD : ');
rga = input('enter the magnitude of the p.v. of the c.g. of link AB from the
fixed pivot A : ');
rgb = input('enter the magnitude of the p.v. of the c.g. of link BC from the
pivot B : ');
rgc = input('enter the magnitude of the p.v. of the c.g. of link CD from the
fixed pivot D : ');
deltaa = input('enter the deviation angle of the p.v. of the c.g. of AB from
the p.v. of pivot B : ');
deltab = input('enter the deviation angle of the p.v. of the c.g. of BC from
the p.v. of pivot C(wrt B) : ');
deltac = input('enter the deviation angle of the p.v. of the c.g. of CD from
the p.v. of pivot C(wrt D) : ');
thetaa = input('enter the input angle (angle between AB and AD) in degrees :
');
omegaa = input('enter the angular velocity of link AB : ');
alphaa = input('enter the angular acceleration of the link AB : ');
Tl = input('enter the load torque : ');

%CONVERTING DEGREES TO RADIANS AND CHECKING FOR FEASIBILITY
thetaa = 3.1415926*thetaa/180;
K = ((a*a) - (b*b) + (c*c) + (d*d))/2;
P = K - (a*(d-c)*cos(thetaa)) - (c*d) ;
Q = -2*a*c*sin(thetaa);
R = K - (a*(d+c)*cos(thetaa)) - (c*d);

flag=0;
if ((Q*Q - 4*P*R)<0) disp('wrong values of the link lengths'); flag=1;
end

%CALCULATION OF OTHER ANGLES
while(flag==0)
thetacl = 2*atan( ((-1*Q) + sqrt(Q*Q - 4*P*R))/(2*P));
thetac2 = 2*atan( ((-1*Q) - sqrt(Q*Q - 4*P*R))/(2*P));
if(thetac1<=0)
thetacl = 2*atan( ((-1*Q) + sqrt(Q*Q - 4*P*R))/(2*P)) + 3.1415926;
end
if(thetac2<=0)
thetac2 = 2*atan( ((-1*Q) - sqrt(Q*Q - 4*P*R))/(2*P)) + 3.1415926;
end

thetab1 = asin( ((c*sin(thetac1)) - (a*sin(thetaa)))/b) ;
thetab2 = asin( ((c*sin(thetac2)) - (a*sin(thetaa)))/b) ;

%CALCULATION OF ANGULAR VELOCITIES
omegab1 = (-1*a*omegaa*sin(thetac1 - thetaa))/(b*sin(thetac1 - thetab1));
omegab2 = (-1*a*omegaa*sin(thetac2 - thetaa))/(b*sin(thetac2 - thetab2));
omegac1 = (-1*a*omegaa*sin(thetab1 - thetaa))/(c*sin(thetac1 - thetab1));
omegac2 = (-1*a*omegaa*sin(thetab2 - thetaa))/(c*sin(thetac2 - thetab2));

%CALCULATION OF ANGULAR ACCELERATIONS

```



```

alphan1 = ((-1*a*alphaa*sin(thetac1 - thetaa)) + (a*omegaa*omegaa*cos(thetac1
-thetaa)) + (b*omegab1*omegab1*cos(thetac1 - thetab1)) -
(c*omegac1*omegac1))/(b*sin(thetac1 - thetab1));
alphan2 = ((-1*a*alphaa*sin(thetac2 - thetaa)) + (a*omegaa*omegaa*cos(thetac2
-thetaa)) + (b*omegab2*omegab2*cos(thetac2 - thetab2)) -
(c*omegac2*omegac2))/(b*sin(thetac2 - thetab2));
alpha1 = ((-1*a*alphaa*sin(thetab1 - thetaa)) + (a*omegaa*omegaa*cos(thetab1
-thetaa)) + (b*omegab1*omegab1) - (c*omegac1*omegac1*cos(thetac1 -
thetab1)))/(c*sin(thetac1 - thetab1));
alpha2 = ((-1*a*alphaa*sin(thetab2 - thetaa)) + (a*omegaa*omegaa*cos(thetab2
-thetaa)) + (b*omegab2*omegab2) - (c*omegac2*omegac2*cos(thetac2 -
thetab2)))/(c*sin(thetac2 - thetab2));

%CALCULATION OF THE ELEMENTS OF THE 'b' MATRIX
b1 = -1*ma*rga*(alphaa*cos(thetaa + deltaa - (3.1415926/2)) +
omegaa*omegaa*cos(thetaa + deltaa));
b2 = ma*9.81 - ma*rga*(alphaa*sin(thetaa + deltaa - (3.1415926/2)) +
omegaa*omegaa*sin(thetaa + deltaa));
b3 = ma*ka*ka*alphaa;
b4 = -1*mb*rgb*(alphan1*cos(thetab1 + deltab - (3.1415926/2)) +
omegab1*omegab1*cos(thetab1 + deltab));
b5 = mb*9.81 - mb*rgb*(alphan1*sin(thetab1 + deltab - (3.1415926/2)) +
omegab1*omegab1*sin(thetab1 + deltab));
b6 = mb*kb*kb*alphan1;
b7 = -1*mc*rgc*(alpha1*cos(thetac1 + deltac - (3.1415926/2)) +
omegac1*omegac1*cos(thetac1 + deltac));
b8 = mc*9.81 - mc*rgc*(alpha1*sin(thetac1 + deltac - (3.1415926/2)) +
omegac1*omegac1*sin(thetac1 + deltac));
b9 = mc*kc*kc*alpha1 - T1;

%CALCULATIONS OF THE ELEMENTS OF THE 'A' MATRIX
A31 = rga*sin(thetaa + deltaa);
A32 = -1*rga*cos(thetaa + deltaa);
A33 = a*sin(thetaa) - rga*cos(thetaa + deltaa);
A34 = rga*cos(thetaa + deltaa) - a*cos(thetaa);
A39 = 1;

A63 = rgb*sin(thetab1 + deltab);
A64 = -1*rga*cos(thetab1 + deltab);
A65 = b*sin(thetab1) - rgb*cos(thetab1 + deltab);
A66 = rgb*cos(thetab1 + deltab) - b*cos(thetab1);

A95 = rgc*cos(thetac1 + deltac) - c*sin(thetac1);
A96 = c*cos(thetac1) - rgc*cos(thetac1 + deltac);
A97 = rgc*sin(thetac1 + deltac);
A98 = -1*rgc*cos(thetac1 + deltac);

B = [b1 b2 b3 b4 b5 b6 b7 b8 b9];
A = [1 0 -1 0 0 0 0 0 0;0 1 0 -1 0 0 0 0 0;A31 A32 A33 A34 0 0 0 0 1;0 0 1 0
-1 0 0 0 0;0 0 0 1 0 -1 0 0 0;0 0 A63 A64 A65 A66 0 0 0;0 0 0 0 1 0 1 0 0;0 0
0 0 1 0 1 0;0 0 0 0 A95 A96 A97 A98 0];

%CALCULATION OF THE FIRST SOLUTION
X = (inv(A))*B';
theta112 = (atan(X(2,1)/X(1,1)))*180/3.1415926; if(X(1,1)<0) theta112 =
(atan(X(2,1)/X(1,1)) + 3.1415926)*180/3.1415926; end
theta123 = (atan(X(4,1)/X(3,1)))*180/3.1415926; if(X(3,1)<0) theta123 =
(atan(X(4,1)/X(3,1)) + 3.1415926)*180/3.1415926; end

```

```

theta134 = (atan(X(6,1)/X(5,1)))*180/3.1415926; if(X(5,1)<0) theta134 =
(atan(X(6,1)/X(5,1)) + 3.1415926)*180/3.1415926; end
theta114 = (atan(X(8,1)/X(7,1)))*180/3.1415926; if(X(7,1)<0) theta114 =
(atan(X(8,1)/X(7,1)) + 3.1415926)*180/3.1415926; end

%CALCULATION OF THE ELEMENTS OF THE 'd' MATRIX
d1 = -1*ma*rga*(alphaa*cos(thetaa + deltaa - (3.1415926/2)) +
omegaa*omegaa*cos(thetaa + deltaa));
d2 = ma*9.81 - ma*rga*(alphaa*sin(thetaa + deltaa - (3.1415926/2)) +
omegaa*omegaa*sin(thetaa + deltaa));
d3 = ma*ka*ka*alphaa;
d4 = -1*mb*rgb*(alphab2*cos(thetab2 + deltab - (3.1415926/2)) +
omegab2*omegab2*cos(thetab2 + deltab));
d5 = mb*9.81 - mb*rgb*(alphab2*sin(thetab2 + deltab - (3.1415926/2)) +
omegab2*omegab2*sin(thetab2 + deltab));
d6 = mb*kb*kb*alphab2;
d7 = -1*mc*rgc*(alphac2*cos(thetac2 + deltac - (3.1415926/2)) +
omegac2*omegac2*cos(thetac2 + deltac));
d8 = mc*9.81 - mc*rgc*(alphac2*sin(thetac2 + deltac - (3.1415926/2)) +
omegac2*omegac2*sin(thetac2 + deltac));
d9 = mc*kc*kc*alphac2 - T1;

%CALCULATIONS OF THE ELEMENTS OF THE 'C' MATRIX
C31 = rga*sin(thetaa + deltaa);
C32 = -1*rga*cos(thetaa + deltaa);
C33 = a*sin(thetaa) - rga*cos(thetaa + deltaa);
C34 = rga*cos(thetaa + deltaa) - a*cos(thetaa);
C39 = 1;

C63 = rgb*sin(thetab2 + deltab);
C64 = -1*rga*cos(thetab2 + deltab);
C65 = b*sin(thetab2) - rgb*cos(thetab2 + deltab);
C66 = rgb*cos(thetab2 + deltab) - b*cos(thetab2);

C95 = rgc*cos(thetac2 + deltac) - c*sin(thetac2);
C96 = c*cos(thetac2) - rgc*cos(thetac2 + deltac);
C97 = rgc*sin(thetac2 + deltac);
C98 = -1*rgc*cos(thetac2 + deltac);

D = [d1 d2 d3 d4 d5 d6 d7 d8 d9];
C = [1 0 -1 0 0 0 0 0 0;0 1 0 -1 0 0 0 0 0;C31 C32 C33 C34 0 0 0 0 1;0 0 1 0
-1 0 0 0 0;0 0 0 1 0 -1 0 0 0;0 0 C63 C64 C65 C66 0 0 0;0 0 0 0 1 0 1 0 0;0 0
0 0 1 0 1 0;0 0 0 0 C95 C96 C97 C98 0];

%CALCULATION OF THE SECOND SOLUTION
Y = (inv(C))*D';
theta212 = (atan(Y(2,1)/Y(1,1)))*180/3.1415926; if(Y(1,1)<0) theta212 =
(atan(Y(2,1)/Y(1,1)) + 3.1415926)*180/3.1415926; end
theta223 = (atan(Y(4,1)/Y(3,1)))*180/3.1415926; if(Y(3,1)<0) theta223 =
(atan(Y(4,1)/Y(3,1)) + 3.1415926)*180/3.1415926; end
theta234 = (atan(Y(6,1)/Y(5,1)))*180/3.1415926; if(Y(5,1)<0) theta234 =
(atan(Y(6,1)/Y(5,1)) + 3.1415926)*180/3.1415926; end
theta214 = (atan(Y(8,1)/Y(7,1)))*180/3.1415926; if(Y(7,1)<0) theta214 =
(atan(Y(8,1)/Y(7,1)) + 3.1415926)*180/3.1415926; end

%DISPLAY OF RESULTS
disp('There are two sets of solutions possible : ');

```

```

disp('Set I : ');
disp('X = [F12x F12y F23x F23y F34x F34y F14x F14y Ts] ');disp(X);
disp('F12 = ');disp(sqrt(X(1,1)^2 + X(2,1)^2));
disp('theta_F12 = ');disp(theta112);
disp('F23 = ');disp(sqrt(X(3,1)^2 + X(4,1)^2));
disp('theta_F23 = ');disp(theta123);
disp('F34 = ');disp(sqrt(X(5,1)^2 + X(6,1)^2));
disp('theta_F34 = ');disp(theta134);
disp('F14 = ');disp(sqrt(X(7,1)^2 + X(8,1)^2));
disp('theta_F14 = ');disp(theta114);

disp('Set II : ');
disp('Y = [F12x F12y F23x F23y F34x F34y F14x F14y Ts] ');disp(Y);
disp('F12 = ');disp(sqrt(Y(1,1)^2 + Y(2,1)^2));
disp('theta_F12 = ');disp(theta212);
disp('F12 = ');disp(sqrt(Y(3,1)^2 + Y(4,1)^2));
disp('theta_F23 = ');disp(theta223);
disp('F12 = ');disp(sqrt(Y(5,1)^2 + Y(6,1)^2));
disp('theta_F34 = ');disp(theta234);
disp('F12 = ');disp(sqrt(Y(7,1)^2 + Y(8,1)^2));
disp('theta_F14 = ');disp(theta214);

flag=flag+2;
end
%END OF CODE

```

Dynamic analysis of Slider Crank Mechanism

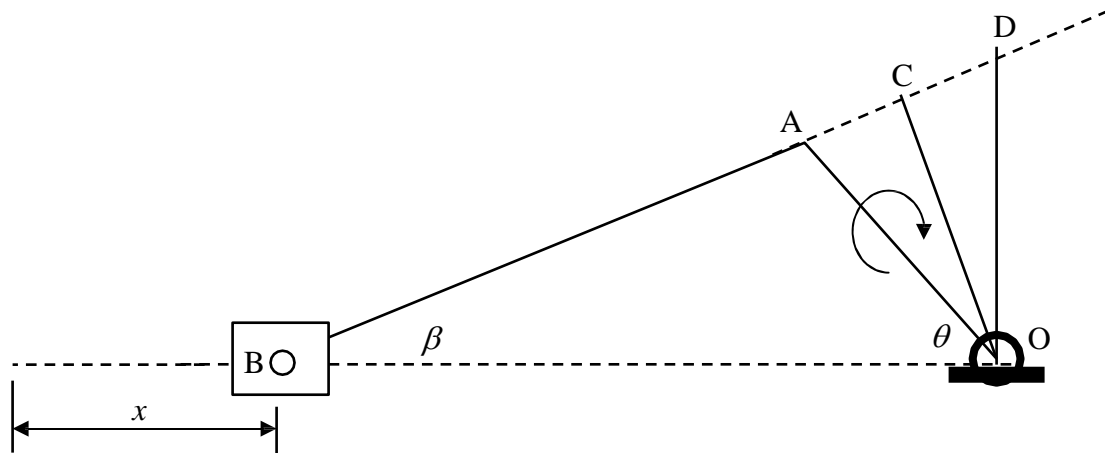

x = displacement of piston from inner dead center

$$\begin{aligned}
 & r[(n+1) - (n \cos \beta + \cos \theta)] \\
 = & r \left[(1 - \cos \theta) + \left(n - \sqrt{n^2 - \sin^2 \theta} \right) \right]
 \end{aligned}$$

If the connecting rod is very large n^2 is very large, and hence $\sqrt{n^2 - \sin^2 \theta}$ will approach n .

The equation converts to

$$x = r(1 - \cos \theta)$$

This is the expression for a SHM. Thus the piston executes SHM when connecting rod is large.

Velocity of Piston:-

$$v = \frac{dx}{dt} = \frac{dx}{d\theta} \cdot \frac{d\theta}{dt}$$

$$= r\omega \sin \theta + \frac{\sin 2\theta}{2\sqrt{n^2 - \sin^2 \theta}} \omega$$

if n^2 is large compared to $\sin^2 \theta$ then

$$v = r\omega \sin \theta + \frac{\sin 2\theta}{2n} \omega$$

If $\frac{\sin 2\theta}{2n}$ can be neglected (when n is quite less) then

$$v = r\omega \sin \theta$$

Acceleration of Piston:-

$$a = \frac{dv}{dt} = \frac{dv}{d\theta} \cdot \frac{d\theta}{dt}$$

$$= \frac{d}{d\theta} \left(r\omega \sin \theta + \frac{\sin 2\theta}{2n} \omega \right) \omega = r\omega^2 \cos \theta + \frac{\cos 2\theta}{n} \omega^2$$

If n is very large $a = r\omega^2 \cos \theta$ which is SHM

When $\theta = 0^\circ$ i.e. at IDC $a = r\omega^2 \left(1 + \frac{1}{n} \right)$

When $\theta = 180^\circ$ i.e. at ODC $a = r\omega^2 \left(1 + \frac{1}{n} \right)$

At $\theta = 180^\circ$ when the direction of motion is reversed $a = r\omega^2 \left(1 - \frac{1}{n} \right)$

Angular Velocity and Angular Acceleration of Connecting rod:-

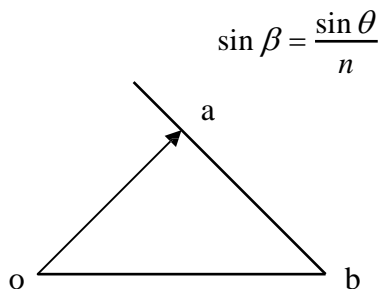

Differentiating $\frac{d\beta}{dt} = \frac{\cos \theta}{n \cos \beta} \omega$

$$\Rightarrow \omega_c = \omega \frac{\cos \theta}{n \frac{1}{n} \sqrt{n^2 - \sin^2 \theta}} = \omega \frac{\cos \theta}{\sqrt{n^2 - \sin^2 \theta}}$$

α_c = angular acceleration of the connecting rod

$$= \frac{d\omega_c}{dt} = \frac{d\omega_c}{d\theta} \cdot \frac{d\theta}{dt} = -\omega^2 \sin \theta \cdot \frac{n^2 - 1}{(n^2 - \sin^2 \theta)^{3/2}}$$

The negative sign indicates that the sense of angular acceleration of the rod is such that it tends to reduce the angle β .

Net or Effective force on the Piston:-

A_1 = area of the cover end

A_2 = area of the piston end

P_1 = pressure of the cover end

P_2 = pressure of the piston end

m = mass of the reciprocating parts

Force on the piston $F_p = P_1 A_1 - P_2 A_2$

Inertia force $F_b = ma = mr\omega^2 \cos \theta + \frac{\cos 2\theta}{n}$

Net or Effective force on the piston $F = F_p - F_b$

Crank Effort:-

It is the net effort (force) applied at the crank pin perpendicular to the crank, which gives the required turning moment on the crankshaft.

F_t = crank effort

F_c = force on the connecting rod

As $F_t r = F_c r \sin(\theta + \beta)$

$$\Rightarrow F_t = F_c \sin(\theta + \beta) = \frac{F}{\cos \beta} \sin(\theta + \beta)$$

$$\begin{aligned}
T &= F_t r \\
&= \frac{F}{\cos \beta} \sin(\theta + \beta) r \\
&= \frac{Fr}{\cos \beta} (\sin \theta \cos \beta + \cos \theta \sin \beta) \\
&= Fr \frac{\sin \theta + \cos \theta \sin \beta}{\cos \beta} \\
&= Fr \left[\sin \theta + \frac{\sin 2\theta}{2\sqrt{n^2 - \sin^2 \theta}} \right]
\end{aligned}$$

Also Then $m_b + m_d = m$ and $m_b b = m_d d$ $r \sin(\theta + \beta) = OD \cos \beta$

$$\begin{aligned}
T &= F_t r \\
&= \frac{F}{\cos \beta} r \sin(\theta + \beta) \\
&= \frac{F}{\cos \beta} (OD \cos \beta) \\
&= F(OD)
\end{aligned}$$

Point masses at two points, if it is ensured that the two masses together have the same dynamic properties.

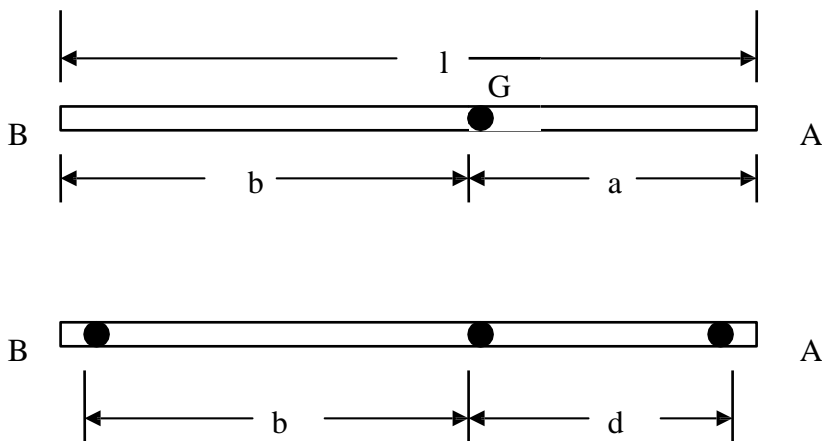

The two member will be dynamically similar if

- (i) The sum of two masses is equal to the total mass
- (ii) The combined centre of mass coincides with that of the rod
- (iii) The moment of inertia of the two point masses about perpendicular axis through their combined centre of mass is equal to that of the rod.

$$m_b + m_d = m$$

$$m_b b = m_d d$$

$$m_b = m \frac{d}{b+d}$$

$$m_d = m \frac{b}{b+d}$$

Let m be the total mass of the rod and one of the masses be located at the small end B. Let the second mass be placed at D and

$$m_b = \text{mass at B}$$

$$m_d = \text{mass at D}$$

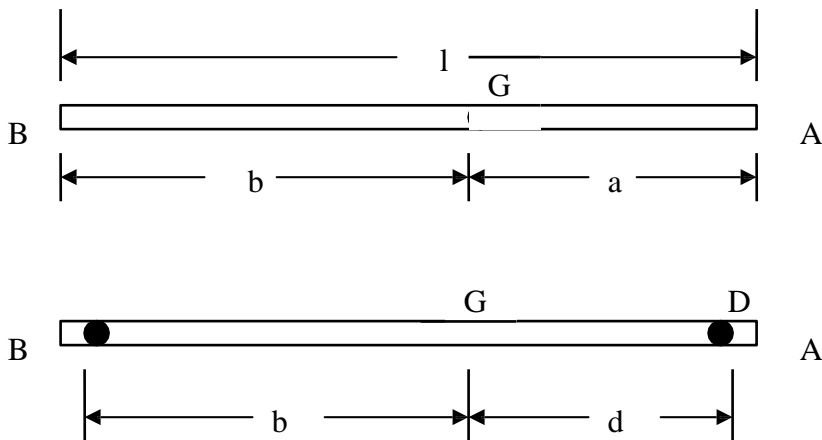

Take $BG = b$

$DG = d$

$$\text{Then } m_b + m_d = m$$

$$\text{and } m_b b = m_d d$$

$$\Rightarrow m_b = m \frac{d}{b+d} \quad \text{and} \quad m_d = m \frac{b}{b+d}$$

$$I = m_b b^2 + m_d d^2$$

$$= m \frac{d}{b+d} b^2 + m \frac{b}{b+d} d^2$$

$$= mbd = mK^2$$

$$\Rightarrow K^2 = bd$$

Instead of keeping the mass at D if we keep at A the first two conditions can be satisfied as follows.

Then $m_b + m_a = m$

and $m_b b = m_a a$

$$\Rightarrow m_b = m \frac{a}{b+a} \quad \text{and} \quad m_a = m \frac{b}{b+a}$$

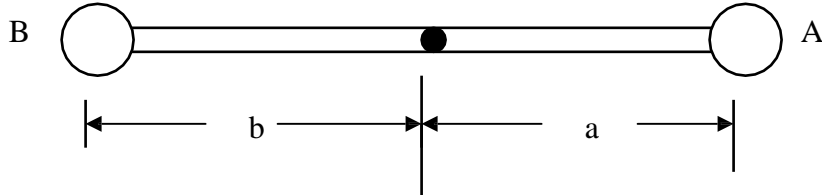

But $I' = mab$, assuming $a > d$, $I' > I$

So by considering the two masses at A and B instead of B and D, the inertia torque is increased

from the actual value of $T = I\alpha$

$$= mb\alpha_c [(a+b) - (b+d)]$$

$$= mb\alpha_c (l - L)$$

This much torque must be applied to the two mass system in the opposite direction to that of angular acceleration to make the system dynamically equivalent to that of the actual rod.

The correction couple will be produced by two equal, parallel, and opposite forces F_y acting at the gudgeon pin and crank pin ends perpendicular to the line of stroke. Force at B is taken by the reaction of guides.

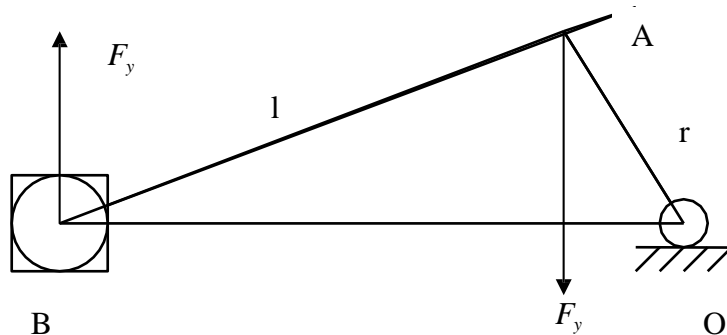

Torque at the crank shaft due to force at A or correction torque,

$$T_c = F_y r \cos \theta$$

$$= \frac{\Delta T}{\cos \beta} r \cos \theta = \frac{mb\alpha_c(l-L)}{l/r} \frac{\cos \theta}{\cos \beta} = \frac{mb\alpha_c(l-L) \cos \theta}{n \frac{1}{\sqrt{n^2 - \sin^2 \theta}}} = mb\alpha_c(l-L) \frac{\cos \theta}{\sqrt{n^2 - \sin^2 \theta}}$$

Also due to weight of mass at A, a torque is exerted on the crankshaft which is given by

$$T_a = (m_a g) r \cos \theta$$

In case of vertical engines, a torque is also exerted on the crankshaft due to weight at B and can be given by,

$$(m_b g) r \sin \theta + \frac{\sin 2\theta}{2\sqrt{n^2 - \sin^2 \theta}}$$

The net torque on the crank shaft will be vectorial sum of the torques T, T_c, T_a and T_b .

Example1: The connecting rod of an IC engine is 450 mm long and has a mass of 2 kg. The center of the mass of the rod is 300 mm from the small end and its radius of gyration about an axis through this center is 175 mm. The mass of the piston and the gudgeon pin is 2.5 kg and the stroke is 300 mm. The cylinder diameter is 115 mm. Determine the magnitude and direction of the torque applied on the crankshaft when the crank is at 40 degree and the piston is moving away from the inner-dead center under an effective gas pressure of 2 N/mm². The engine speed is 1000 rpm.

Solution:

$$n = l/r = 450/150 = 3.$$

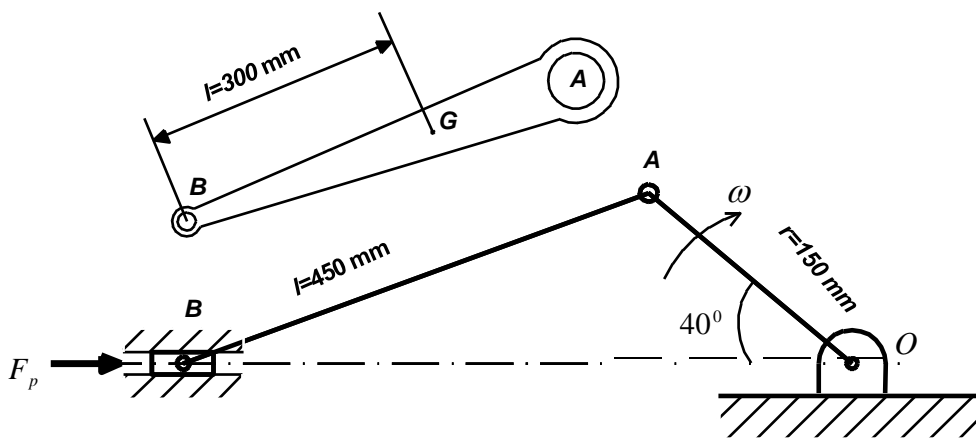

Inertia forces due to reciprocating masses:

Divide the mass of the rod into two dynamically equivalent parts

Mass of the crank pin, $m_a = (m b) / l = 2 \times 300 / 450$ where m is mass of the rod
 $= 1.333 \text{ kg}.$

Mass at the gudgeon pin, $m_b = 2 - 1.3333 = 0.6667 \text{ kg}.$

Total mass of the reciprocating parts, $m = 2.5 + 0.6667 = 3.16667 \text{ kg}$

$$\begin{aligned} \text{Inertia force due to reciprocating masses, } F_b &= mr\omega^2 \frac{\cos \theta + \cos 2\theta}{n} \\ &= 3.1667 \times 0.15 \times (2\pi \times 1000 / 60)^2 (\cos 40 + (\cos 80) / 3) \\ &= 4290.6 \text{ N.} \end{aligned}$$

Force on the piston, $F_p = 2 \times 10^6 \times \pi / 4 \times (0.115)^2 = 20773.8 \text{ N}$

Net force, $F = F_p - F_b$

$$\begin{aligned} \text{Torque due to this force, } T &= Fr \sin \theta + \frac{\sin 2\theta}{2\sqrt{n^2 - \sin^2 \theta}} \\ T &= 2004.7 \text{ Nm} \end{aligned}$$

Torque to consider the correction couple:

$$\begin{aligned} \alpha_c &= -\omega^2 \sin \theta \frac{n^2 - 1}{(n^2 - \sin^2 \theta)^{3/2}} \frac{r}{f} \\ &= -2240.3 \text{ rad/s}^2. \end{aligned}$$

$L = b + d = b + k^2/b = 402.08 \text{ mm}.$

$$\begin{aligned} T_c &= mb\alpha_c(l - L) \frac{\cos \theta}{\sqrt{n^2 - \sin^2 \theta}} \text{ where } m \text{ is mass of the rod} \\ &= -16.84 \text{ Nm} \end{aligned}$$

Torque due to mass at A:

$$\begin{aligned} T_a &= m_a g r \cos \theta \\ &= 1.503 \text{ Nm.} \end{aligned}$$

Total torque on the crankshaft:

$$\begin{aligned} \text{Net torque on the crank shaft} &= T - T_c + T_a \\ &= 2004.7 + 16.84 + 1.503 \\ &= 2021.1 \text{ Nm. (answer)} \end{aligned}$$

Example 2: The connecting rod of a vertical reciprocating engine is 2 m long and has a weight of 300 kg. The mass center is 825 mm from big end bearing. When suspended as pendulum from

the gudgeon pin axis, it makes 10 complete oscillations in 25 sec. Calculate radius of gyration of the connecting rod. The crank is 400 mm long and rotates at 200 rpm. When the crank has turned through 45 degree from the top dead center and the piston is moving downwards, analytically and graphically find the torque acting at the crankshaft.

Solution:

$$n = l/r = 2000/400 = 5.$$

Inertia forces due to reciprocating mass:

Divide the mass of the rod into two dynamically equivalent parts

Mass of the crank pin, $m_a = m \cdot b \cdot l = 300 \times (2 - 0.825) / 2$ (where m is mass

of the rod)

$$= 176.35 \text{ kg.}$$

Mass at the gudgeon pin, $m_b = 300 - 176.25 = 123.75 \text{ kg.}$

Inertia force due to reciprocating masses, $F = m_b r \omega^2 \left[\frac{\cos \theta + \cos 2\theta}{n} \right]$

$$F = 123.75 \times 0.4 \times (2\pi \times 200/60)^2 (\cos 45 + (\cos 90)/5)$$

$$F = 15348 \text{ N.}$$

Torque due to this force, $T = Fr \left[\frac{\sin \theta + \frac{\sin 2\theta}{2\sqrt{n^2 - \sin^2 \theta}} \right]$

$$T = 4967.6 \text{ Nm}$$

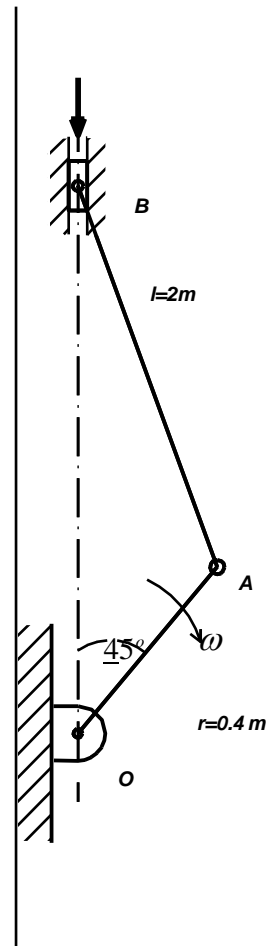

Torque to consider the correction couple:

We know that $b + d = b + k^2/b = L$

$$b = 2 - 0.825 = 1.175 \text{ m}$$

and $t = 2\pi \sqrt{\frac{L}{g}} = 25/10$

$$\text{∴ } L = 1.553 \text{ m}$$

Now, $1.175 + k^2/1.175 = 1.553$

∅ $k = 0.6665 \text{ m}$.

$$\alpha_c = -\omega^2 \sin \theta \frac{Y}{(n^2 - \sin^2 \theta)^{3/2}} \frac{1}{f}$$

$$= -61.36 \text{ rad/s}^2.$$

$$T_c = mb\alpha_c(l-L) \frac{\cos \theta}{\sqrt{n^2 - \sin^2 \theta}} \text{ where } m \text{ is mass of the rod.}$$

$$= -1381.2 \text{ Nm}$$

Torque due to weight of mass at A:

$$T_a = m_a g r \sin \theta$$

$$= 489 \text{ Nm.}$$

Torque due to weight of mass at B:

$$T = m_b g r \sin \theta + \frac{\sin 2\theta}{2\sqrt{n^2 - \sin^2 \theta}}$$

$$= 392 \text{ Nm}$$

Total inertia torque on the crankshaft:

Total inertia torque on the crankshaft = $4967.6 - (-1381.2) - 489 - 392$

$$= 5466.7 \text{ Nm.}$$

Graphical method:

Klein's construction is shown in the following diagram.

From the diagram,

$$gO = 0.3282 \text{ m, IY} = 1.0318 \text{ m, IX} = 2.0952 \text{ m, IP} = 2.2611 \text{ m, IC} = 2.7977 \text{ mm.}$$

We know that,

$$F_C = m_c \omega^2 (gO) = 300 \times (20.94)^2 \times 0.3282 = 43173.1 \text{ N}$$

$$W_C = 300 \times 9.81 = 2943 \text{ N}$$

Now, take the moment of the forces about the point I.

$$F_T \times (IC) = F_C \times (IY) - W_C \times (IX)$$

From this we can calculate the unknown F_T

$$F_T = 13714 \text{ N}$$

Inertia torque, $T = F_T \times r = 13705 \times 0.4 = 5487 \text{ Nm.}$

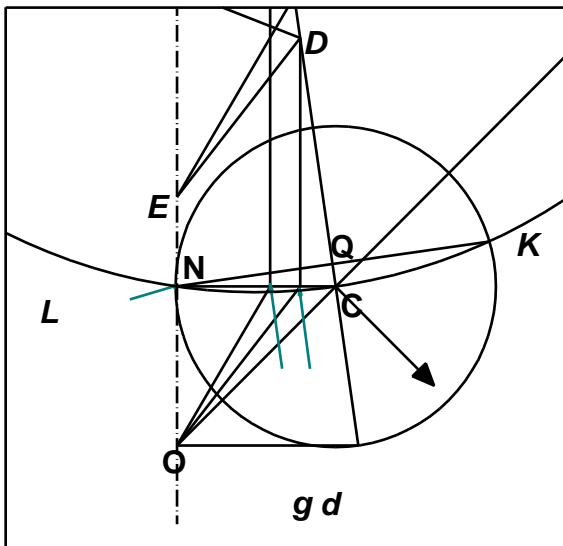
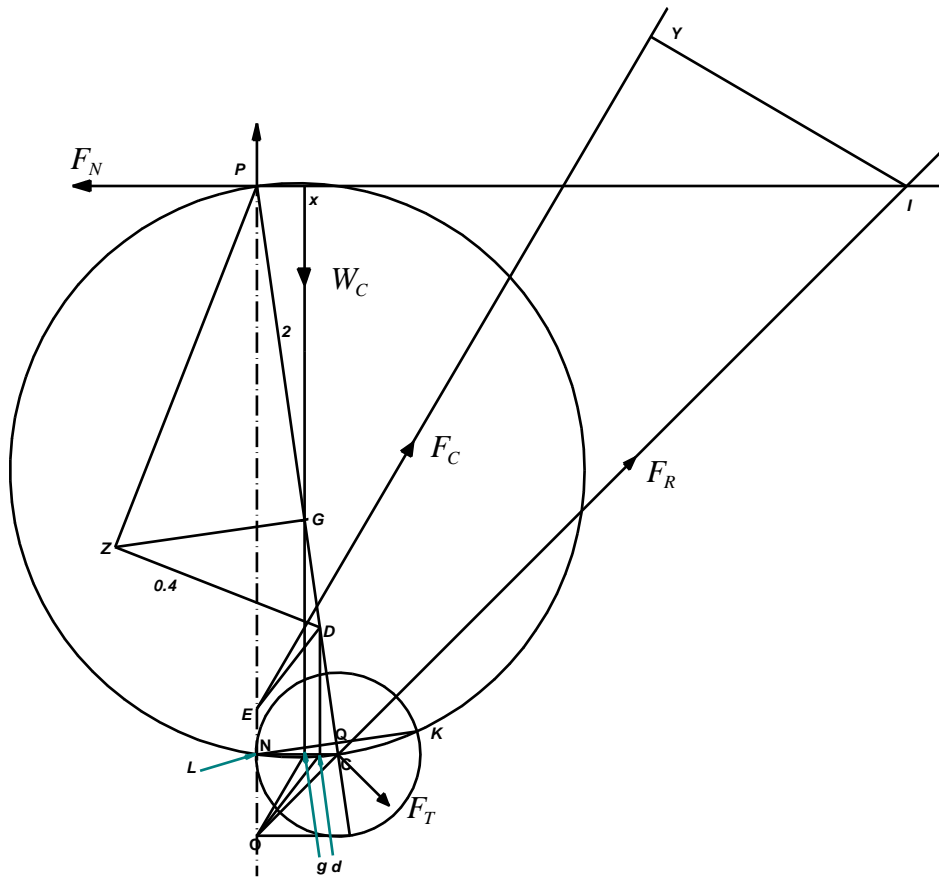

Summery

In this chapter the following concepts are learned

- Inertia forces and couples
- Offset inertia force
- Dynamically equivalent system
- Determination of radius of gyration of crankshaft by method of oscillation
- Piston effort, crank effort
- Dynamic force analysis of mechanisms using graphical method, vector method and virtual work principle

Exercise Problems

1. Determine the torque required to drive link AB of the four bar mechanism in the position shown in figure below under the action of forces F_2 and F_3 with magnitudes of 50 N and 75 N, respectively. Force F_2 acts in the horizontal direction and F_3 acts as shown in the figure. Weight of links AB, BC and CD are 5 N, 7.5 N and 8 N respectively. $AB=30$ cm, $BC=40$ cm, $CD=50$ cm and the fixed link $AD=75$ cm and $CE=15$ and $CF=20$ cm. Crank AB is rotating at 100rpm in clockwise direction, Use both graphical and analytical methods

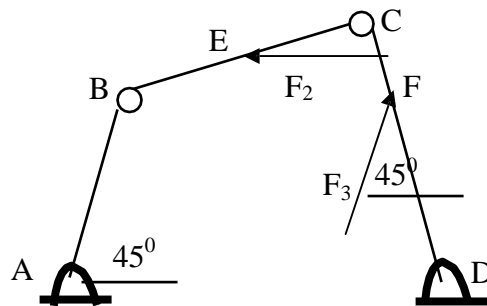

2. Assuming $F_2 = F_3 = 0$, determine the torque required to overcome the inertia forces of the links of the four bar mechanism in problem 1 if (a) link AB accelerated at the rate of 5 rad/sec^2 , (b) decelerated at the rate of 5 rad/sec^2 . Use virtual work principle, graphical and vector method to solve the problem.

3 The connecting rod of a reciprocating compressor is 2 m long and has a weight of 300 kg. The mass center is 825 mm from big end bearing. The radius of gyration of the connecting rod is 0.7 m. The crank is 420 mm long and rotates at 250 rpm. When the crank has turned through 225 degree from the inner dead center and the piston is moving towards left, analytically and graphically find the torque acting at the crankshaft. Consider mass of crank, connecting rod and piston to be 5 kg, 4 kg and 2 kg respectively.

4. Figure below shows a mechanism used to crush rocks. Considering mass of link AB, BC and CDE to be 0.8, 1 and 1.5 respectively, in the position shown, determine the torque required to drive the input link AB when the crushing force acting in the horizontal direction is 5000N. Here, $AB = 50$ cm, $BC=100$ cm, $CD=120$ cm and the fixed link $AD=150$ cm and $CE=25$ cm and

the angle CED of the ternary link CED is 90° . Assuming link AB is rotating with 500 rpm in clockwise direction, use (a) graphical method, (b) analytical method and (c) virtual work principle to determine the bearing forces and power required by the motor.

