

REGISTERS

Flip-flop is a 1 bit memory cell which can be used for storing the digital data. To increase the storage capacity in terms of number of bits, we have to use a group of flip-flop. Such a group of flip-flop is known as a **Register**. The **n-bit register** will consist of **n** number of flip-flop and it is capable of storing an **n-bit** word.

The binary data in a register can be moved within the register from one flip-flop to another. The registers that allow such data transfers are called as **shift registers**. There are four mode of operations of a shift register.

- Serial Input Serial Output
- Serial Input Parallel Output
- Parallel Input Serial Output
- Parallel Input Parallel Output

Serial Input Serial Output

Let all the flip-flop be initially in the reset condition i.e. $Q_3 = Q_2 = Q_1 = Q_0 = 0$. If an entry of a four bit binary number 1 1 1 1 is made into the register, this number should be applied to **D_{in}** bit with the LSB bit applied first. The D input of FF-3 i.e. **D₃** is connected to serial data input **D_{in}**. Output of FF-3 i.e. **Q₃** is connected to the input of the next flip-flop i.e. **D₂** and so on.

Block Diagram

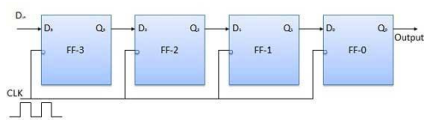

Operation

Before application of clock signal, let $Q_3 Q_2 Q_1 Q_0 = 0000$ and apply LSB bit of the number to be entered to **D_{in}**. So **D_{in} = D₃ = 1**. Apply the clock. On the first falling edge of clock, the FF-3 is set, and stored word in the register is $Q_3 Q_2 Q_1 Q_0 = 1000$.

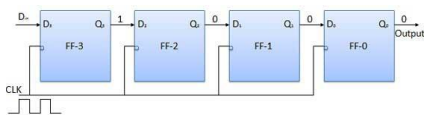

Apply the next bit to **D_{in}**. So **D_{in} = 1**. As soon as the next negative edge of the clock hits, FF-2 will set and the stored word change to $Q_3 Q_2 Q_1 Q_0 = 1100$.

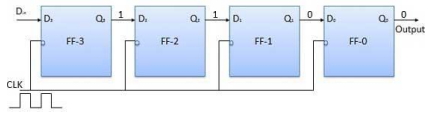

Apply the next bit to be stored i.e. 1 to D_{in} . Apply the clock pulse. As soon as the third negative clock edge hits, FF-1 will be set and output will be modified to $Q_3 Q_2 Q_1 Q_0 = 1110$.

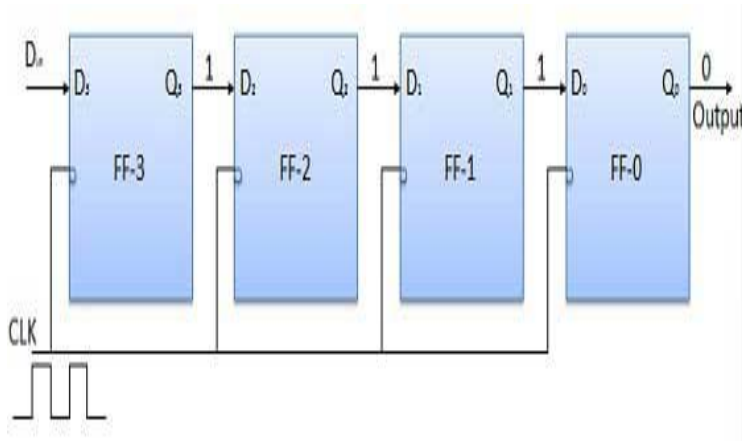

Similarly with $D_{in} = 1$ and with the fourth negative clock edge arriving, the stored word in the register is $Q_3 Q_2 Q_1 Q_0 = 1111$.

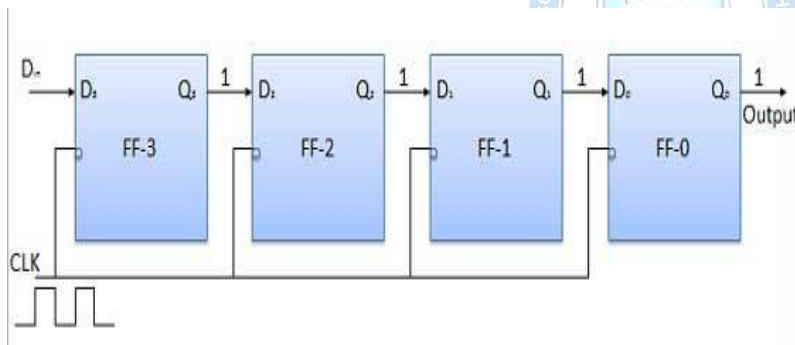

Truth Table

	CLK	$D_n = Q_n$	$Q_n = D_n$	$Q_{n-1} = D_n$	$Q_{n-2} = D_n$	Q_n
Initially			0	0	0	0
(i)	↓	1	1	0	0	0
(ii)	↓	1	1	1	0	0
(iii)	↓	1	1	1	1	0
(iv)	↓	1	1	1	1	1

→ Direction of data travel

Waveforms

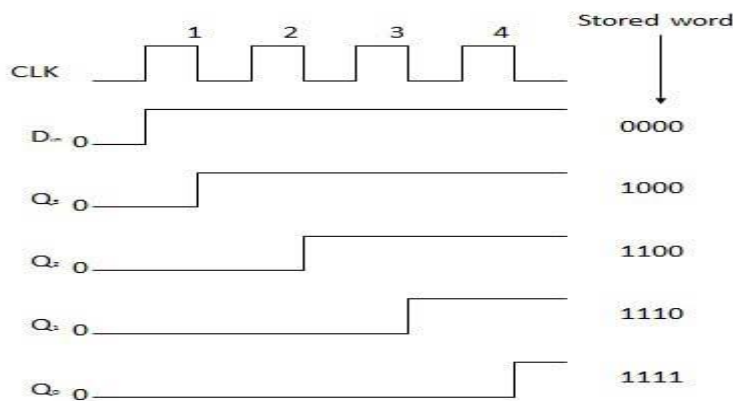

Serial Input Parallel Output

- In such types of operations, the data is entered serially and taken out in parallel fashion.
- Data is loaded bit by bit. The outputs are disabled as long as the data is loading.
- As soon as the data loading gets completed, all the flip-flops contain their required data, the outputs are enabled so that all the loaded data is made available over all the output lines at the same time.
- 4 clock cycles are required to load a four bit word. Hence the speed of operation of SIPO mode is same as that of SISO mode.

Block Diagram

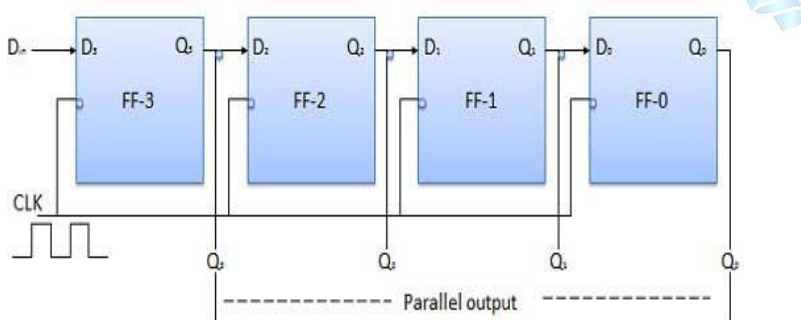

Parallel Input Serial Output (PISO)

- Data bits are entered in parallel fashion.
- The circuit shown below is a four bit parallel input serial output register.
- Output of previous Flip Flop is connected to the input of the next one via a combinational circuit.
- The binary input word B_0, B_1, B_2, B_3 is applied though the same combinational circuit.

- There are two modes in which this circuit can work namely - shift mode or load mode.

Load mode

When the shift/load bar line is low (0), the AND gate 2, 4 and 6 become active they will pass B_1 , B_2 , B_3 bits to the corresponding flip-flops. On the low going edge of clock, the binary input B_0 , B_1 , B_2 , B_3 will get loaded into the corresponding flip-flops. Thus parallel loading takes place.

Shift mode

When the shift/load bar line is high (1), the AND gate 2, 4 and 6 become inactive. Hence the parallel loading of the data becomes impossible. But the AND gate 1,3 and 5 become active. Therefore the shifting of data from left to right bit by bit on application of clock pulses. Thus the parallel in serial out operation takes place.

Block Diagram

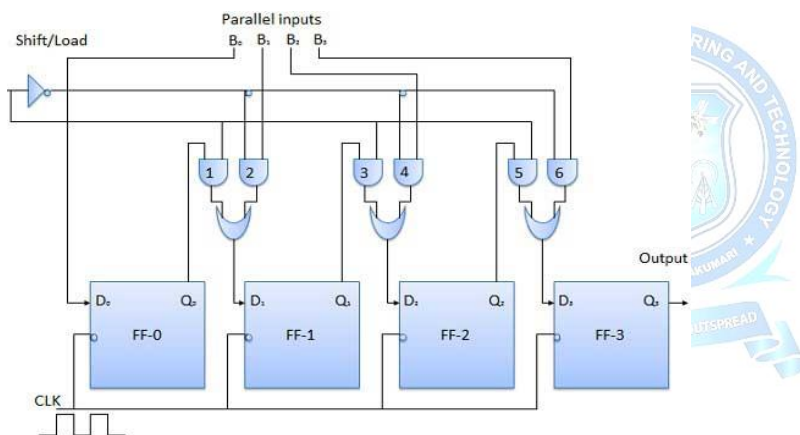

Parallel Input Parallel Output (PIPO)

In this mode, the 4 bit binary input B_0 , B_1 , B_2 , B_3 is applied to the data inputs D_0 , D_1 , D_2 , D_3 respectively of the four flip-flops. As soon as a negative clock edge is applied, the input binary bits will be loaded into the flip-flops simultaneously. The loaded bits will appear simultaneously to the output side. Only clock pulse is essential to load all the bits.

Block Diagram

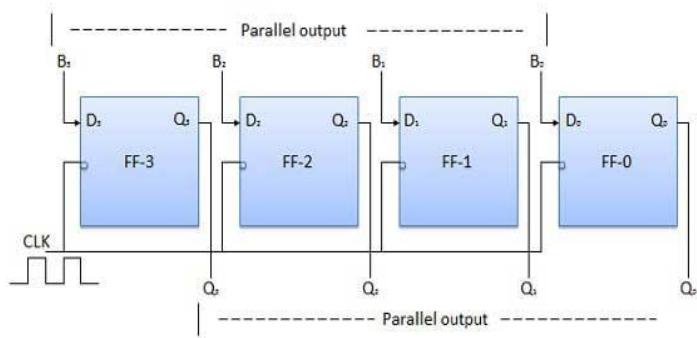

Bidirectional Shift Register

- If a binary number is shifted left by one position then it is equivalent to multiplying the original number by 2. Similarly if a binary number is shifted right by one position then it is equivalent to dividing the original number by 2.
- Hence if we want to use the shift register to multiply and divide the given binary number, then we should be able to move the data in either left or right direction.
- Such a register is called bi-directional register. A four bit bi-directional shift register is shown in fig.
- There are two serial inputs namely the serial right shift data input DR, and the serial left shift data input DL along with a mode select input (M).

Block Diagram

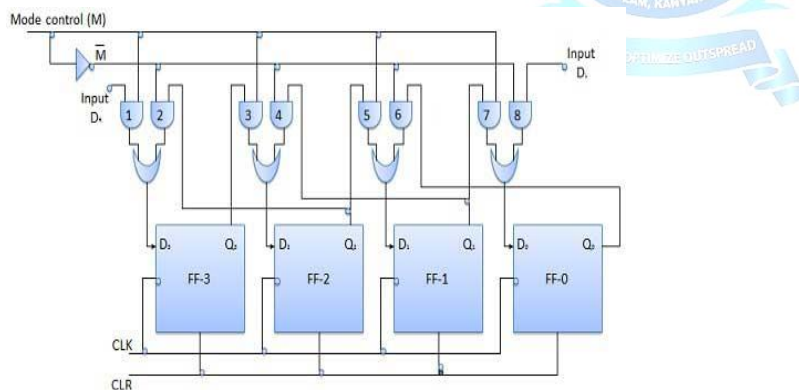

Operation

S.N.	Condition	Operation
1	With M = 1 – Shift right operation	If M = 1, then the AND gates 1, 3, 5 and 7 are enabled whereas the remaining AND gates 2, 4, 6 and 8 will be disabled.

		The data at D_R is shifted to right bit by bit from FF-3 to FF-0 on the application of clock pulses. Thus with $M = 1$ we get the serial right shift operation.
2	With $M = 0$ – Shift left operation	<p>When the mode control M is connected to 0 then the AND gates 2, 4, 6 and 8 are enabled while 1, 3, 5 and 7 are disabled.</p> <p>The data at D_L is shifted left bit by bit from FF-0 to FF-3 on the application of clock pulses. Thus with $M = 0$ we get the serial right shift operation.</p>

Universal Shift Register

A shift register which can shift the data in only one direction is called a uni-directional shift register. A shift register which can shift the data in both directions is called a bi-directional shift register. Applying the same logic, a shift register which can shift the data in both directions as well as load it parallelly, is known as a universal shift register. The shift register is capable of performing the following operation –

- Parallel loading
- Left Shifting
- Right shifting

The mode control input is connected to logic 1 for parallel loading operation whereas it is connected to 0 for serial shifting. With mode control pin connected to ground, the universal shift register acts as a bi-directional register. For serial left operation, the input is applied to the serial input which goes to AND gate-1 shown in figure. Whereas for the shift right operation, the serial input is applied to D input.

Block Diagram

ROHINI COLLEGE OF ENGINEERING AND TECHNOLOGY

