

## **Communication Payload and Supporting Subsystems**

The physical principle of establishing communication connections between remote communication devices dates back to the late 1800s when scientists were beginning to understand electromagnetism and discovered that electromagnetic radiation generated by one device can be detected by another located at some distance away.

By controlling certain aspects of the radiation, useful information can be embedded in the EM waves and transmitted from one device to another. The second major module is the communication payload, which is made up of transponders. A transponder is capable of -

- Receiving uplinked radio signals from earth satellite transmission stations (antennas).
- Amplifying received radio signals.
- Sorting the input signals and directing the output signals through input/output signal multiplexers to the proper downlink antennas for retransmission to earth satellite receiving stations (antennas).

## **Telemetry, Tracking and Command Subsystem (TTC)**

The TT&C subsystem performs several routine functions aboard the spacecraft. The telemetry function could be interpreted as *measurement at a distance*. It refers to the overall operation of generating an electrical signal proportional to the quantity being measured and encoding and transmitting this to a distant station, which for the satellite is one of the earth stations.

Data transmitted as telemetry signals include attitude information such as that obtained from sun and earth sensors; environmental information such as the magnetic field intensity and direction, the frequency of meteorite impact etc and spacecraft information such as temperatures, power supply voltages, and stored-fuel pressure.

The telemetry subsystem transmits information about the satellite to the earth station, while the command subsystem receives command signals from the earth station, often in response to telemetered information. The command subsystem demodulates and decodes the command signals and routes these to the appropriate equipment needed to execute the necessary action. Thus attitude changes may be made, communication transponders switched in and out of circuits, antennas redirected, and station-keeping maneuvers carried out on command. It is important to prevent unauthorized commands from being received and decoded, and the command signals are often encrypted.

*Encrypt* is derived from a Greek word *kryptein*, meaning *to hide*, and represents the process of concealing the command signals in a secure code. This differs from the normal process of encoding which converts characters in the command signal into a code suitable for transmission. Tracking of the satellite is accomplished by having the satellite transmit beacon signals which are received at the TT&C earth stations. Tracking is obviously important during the transfer and drift orbital phases of the satellite launch. Once it is on station, the position of a geo-stationary satellite will tend to be shifted as a result of the various disturbing forces. Therefore, it is necessary to be able to track the satellite's movement and send correction signals as required.

## **Transponders**

A transponder is the series of interconnected units which forms a single communications channel between the receive and transmit antennas in a communications satellite. Some of the units utilized by a transponder

in a given channel may be common to a number of transponders. Thus, although reference may be made to a specific transponder, this must be thought of as an equipment *channel* rather than a single item of equipment.

Before describing in detail the various units of a transponder, the overall frequency arrangement of a typical C-band communications satellite will be examined briefly. The bandwidth allocated for C-band service is 500 MHz, and this is divided into sub-bands, one transponder.

A typical transponder bandwidth is 36 MHz, and allowing for a 4-MHz guard-band between transponders, 12 such transponders can be accommodated in the 500-MHz bandwidth.

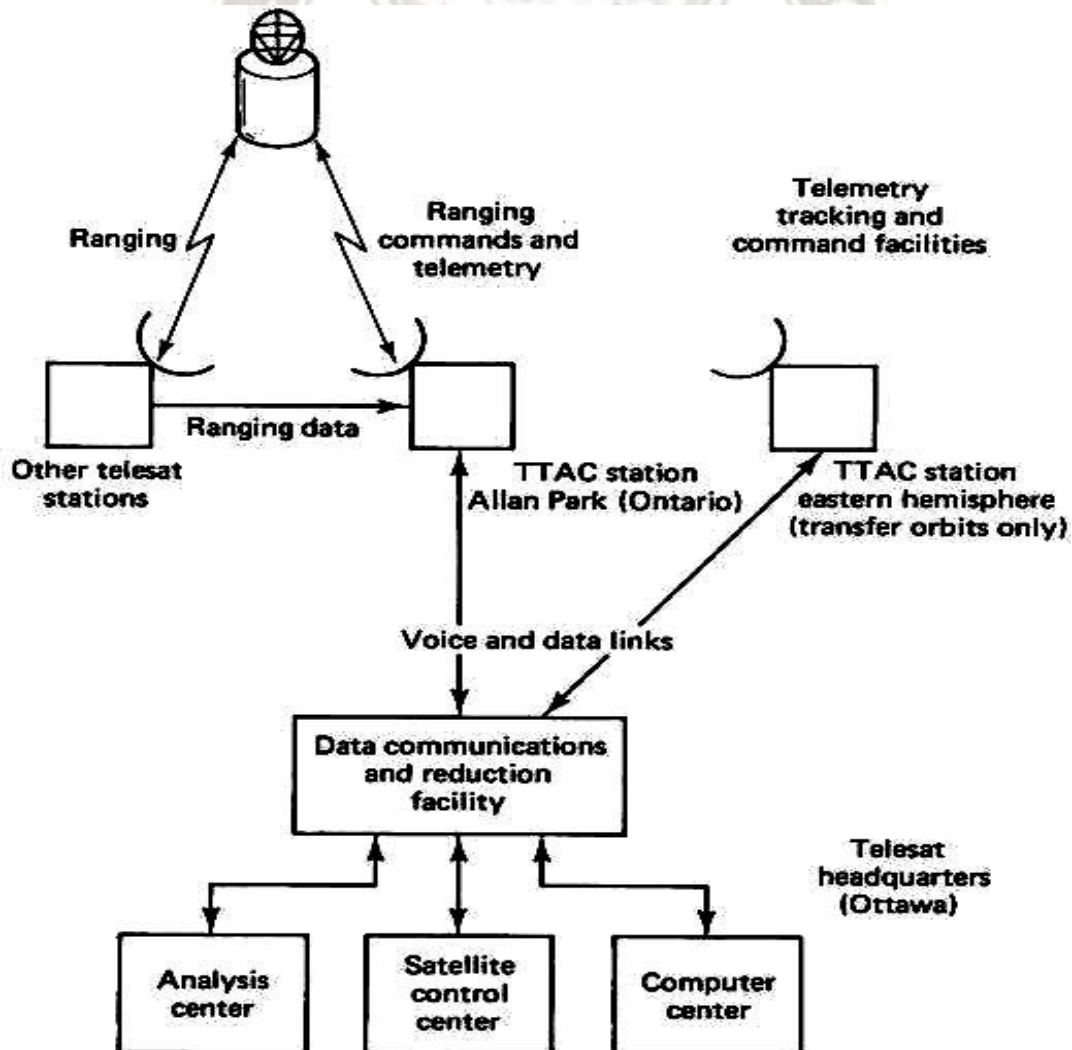

Fig 2.7 Satellite Control System

By making use of *polarization isolation*, this number can be doubled. Polarization isolation refers that carriers, which may be on the same frequency but with opposite senses of polarization, can be isolated from one another by receiving antennas matched to the incoming polarization. With linear polarization, vertically and horizontally polarized carriers can be separated in this way, and with circular polarization, left-hand circular and right-hand circular polarizations can be separated. Because the carriers with opposite senses of polarization may overlap in frequency, this technique is referred to as *frequency reuse*. Figure 2.8 shows part of the frequency and polarization plan for a C-band communications satellite.

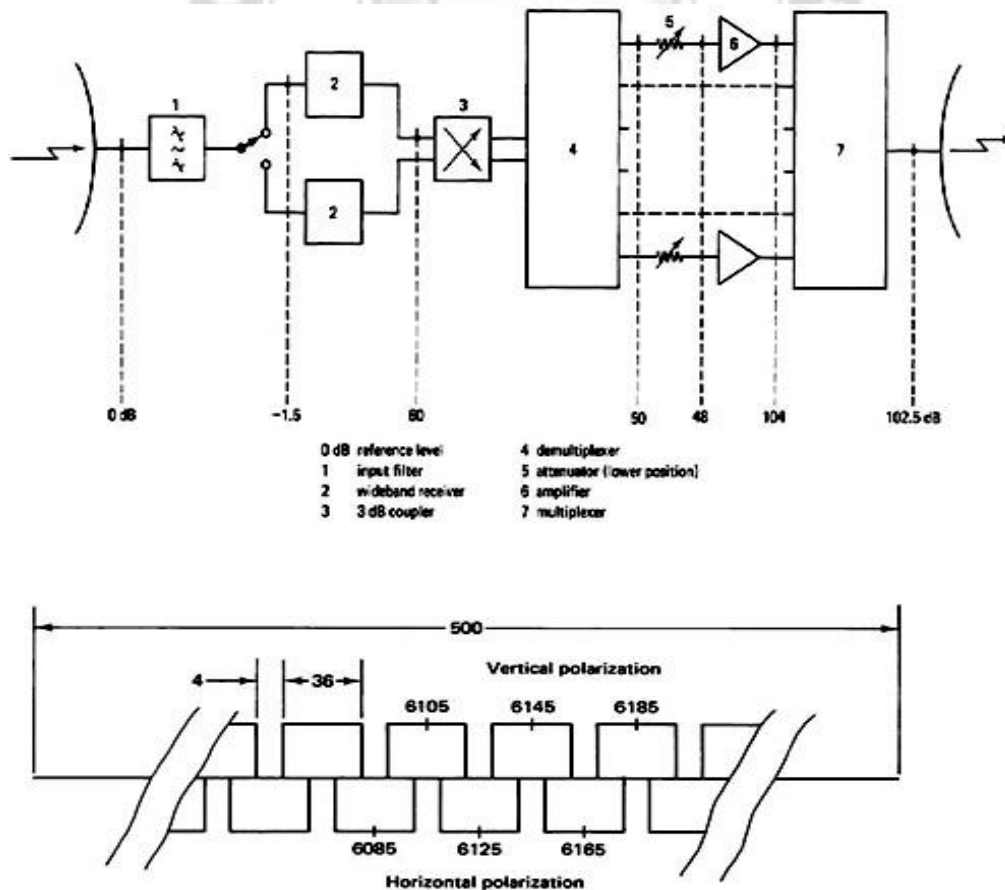

Fig 2.8 Section of an Uplink Frequency and Polarization Plan

Frequency reuse also may be achieved with spot-beam antennas, and these may be combined with polarization reuse to provide an effective bandwidth of 2000 MHz from the actual bandwidth of 500 MHz. For one of the polarization groups, Figure 2.8 shows the channeling scheme for the 12 transponders in more detail. The incoming, or uplink, frequency range is 5.925 to 6.425 GHz. The frequency conversion shifts the carriers to the downlink frequency band, which is also 500 MHz wide, extending from 3.7 to 4.2 GHz. At this point the signals are channelized into frequency bands which represent the individual transponder bandwidths.

### **The wideband receiver**

The wideband receiver is shown in more detail in Fig. 2.10. A duplicate receiver is provided so that if one fails, the other is automatically switched in. The combination is referred to as a *redundant receiver*, meaning that although two are provided, only one is in use at a given time.

The first stage in the receiver is a *low-noise amplifier* (LNA). This amplifier adds little noise to the carrier being amplified, and at the same time it provides sufficient amplification for the carrier to override the higher noise level present in the following mixer stage.

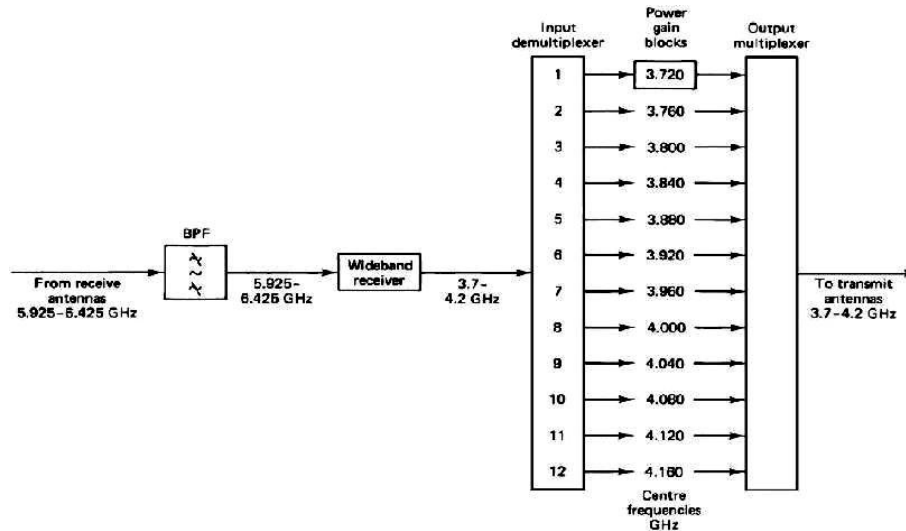

Fig 2.9 Satellite Transponder Channels

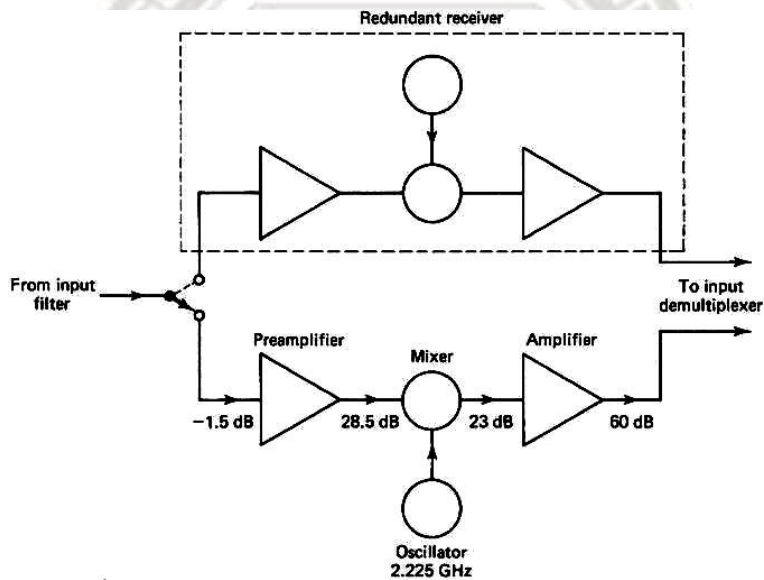

Fig 2.10 Satellite Wideband Receiver

It is more convenient to refer all noise levels to the LNA input, where the total receiver noise may be expressed in terms of an equivalent noise temperature. In a well-designed receiver, the equivalent noise temperature referred to the LNA input is basically that of the LNA alone. The overall noise temperature must take into account the noise added from the antenna. The equivalent noise temperature of a satellite receiver may be on the order of a few hundred kelvins.

The LNA feeds into a mixer stage, which also requires a *local oscillator* (LO) signal for the frequency-conversion process. With

advances in *field-effect transistor* (FET) technology, FET amplifiers, which offer equal or better performance, are now available for both bands. Diode mixer stages are used. The amplifier following the mixer may utilize *bipolar junction transistors* (BJTs) at 4 GHz and FETs at 12 GHz, or FETs may in fact be used in both bands.

### The input de-multiplexer

The input de-multiplexer separates the broadband input, covering the frequency range 3.7 to 4.2 GHz, into the transponder frequency channels. This provides greater frequency separation between adjacent channels in a group, which reduces adjacent channel interference. The output from the receiver is fed to a power splitter, which in turn feeds the two separate chains of circulators.

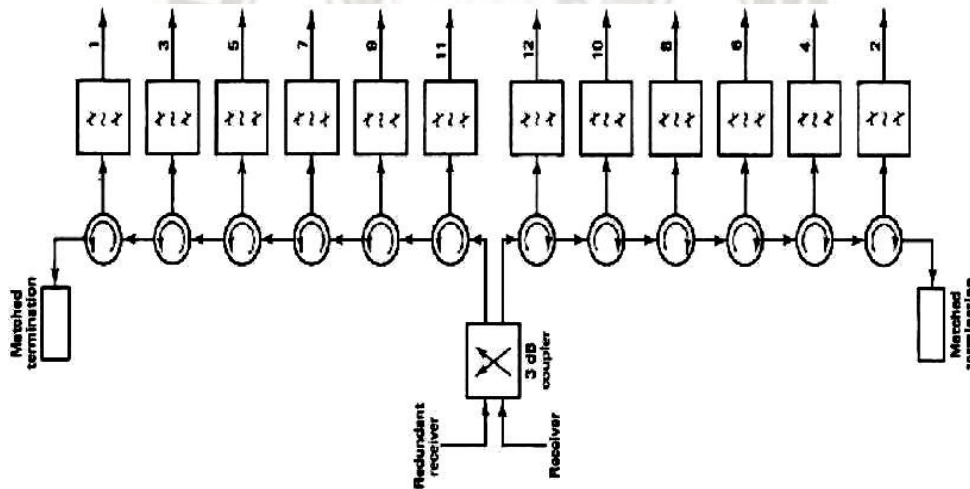

Fig 2.11 Satellite Input Multiplexer

The full broadband signal is transmitted along each chain, and the channelizing is achieved by means of channel filters connected to each circulator. Each filter has a bandwidth of 36 MHz and is tuned to the appropriate center frequency, as shown in Fig. 2.11. Although there are considerable losses in the demultiplexer, these are easily made up in the overall gain for the transponder channels.

### The power amplifier

The fixed attenuation is needed to balance out variations in the

input attenuation so that each transponder channel has the same nominal attenuation, the necessary adjustments being made during assembly. The variable attenuation is needed to set the level as required for different types of service. Because this variable attenuator adjustment is an operational requirement, it must be under the control of the ground TT&C station.

*Traveling-wave tube amplifiers (TWTAs)* are widely used in transponders to provide the final output power required to the transmit antenna. Figure 2.12 shows the schematic of a *traveling wave tube (TWT)* and its power supplies. In the TWT, an electron-beam gun assembly consisting of a heater, a cathode, and focusing electrodes is used to form an electron beam. A magnetic field is required to confine the beam to travel along the inside of a wire helix.

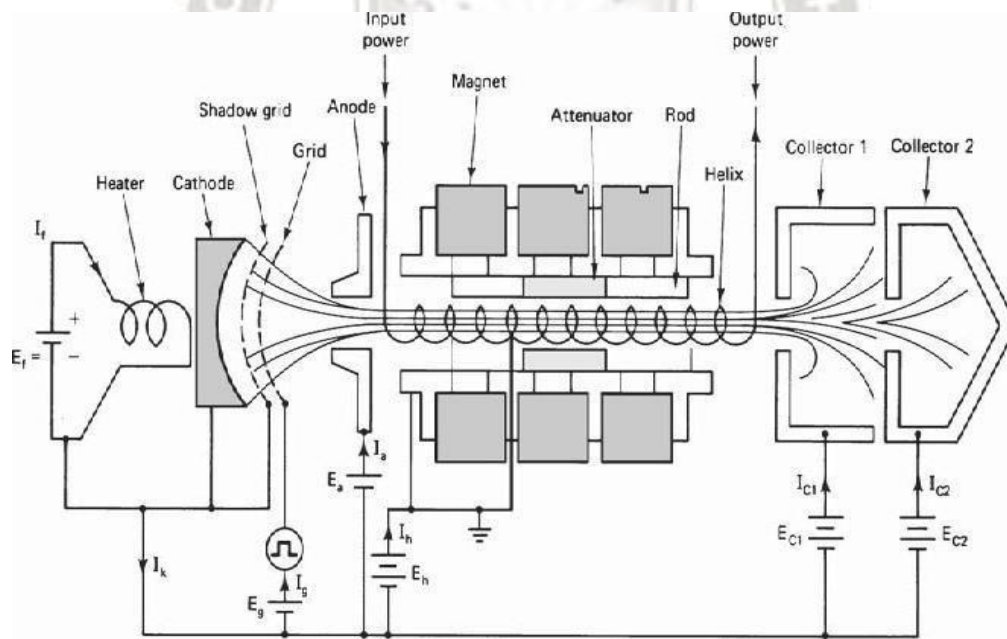

**Fig 2.12** Satellite TWT

The magnetic field can be provided by means of a solenoid and dc power supply. The comparatively large size and high power consumption of solenoids make them unsuitable for use aboard satellites and lower-power TWTs are used which employ permanent-magnet focusing. The wave will travel around the helical path at close to the speed of light, but it is the axial component of wave velocity which



interacts with the electron beam.

This component is less than the velocity of light approximately in the ratio of helix pitch to circumference. Because of this effective reduction in phase velocity, the helix is referred to as a *slow wave structure*. The advantage of the TWT over other types of tube amplifiers is that it can provide amplification over a very wide bandwidth. Input levels to the TWT must be carefully controlled, however to minimize the effects of certain forms of distortion. The results from the nonlinear transfer characteristic of the TWT are illustrated in Figure 2.13.

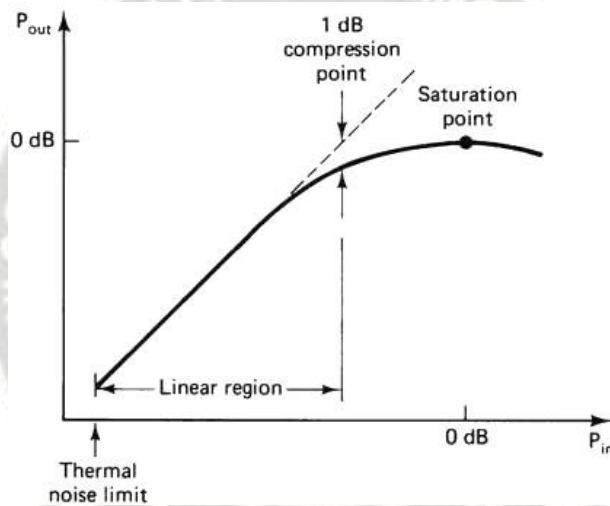

Fig 2.13 Power Transfer Characteristics of a TWT

At low-input powers, the output-input power relationship is linear. At higher power inputs, the output power saturates, the point of maximum power output being known as the *saturation point*. The saturation point is a very convenient reference point and input and output quantities are usually referred to it. The linear region of the TWT is defined as the region bound by the thermal noise limit at the low end and by what is termed the *1-dB compression point* at the upper end. This is the point where the actual transfer curve drops.

## Satellite Uplink and Downlink Analysis and Design

### Introduction

The link-power budget calculations basically relate two quantities, the transmit power and the receive power, and show in detail how the difference between these two powers is accounted for. Link-budget calculations are usually made using decibel or decilog quantities. Where no ambiguity arises regarding the units, the abbreviation dB is used. For example, Boltzmann's constant is given as 228.6 dB, although, strictly speaking, this should be given as 228.6 deci logs relative to 1 J/K.

### Equivalent Isotropic Radiated Power

A key parameter in link-budget calculations is the *equivalent isotropic radiated power*, conventionally denoted EIRP. The maximum power flux density at some distance ' $r$ ' for transmitting antenna of gain ' $G$ '

$$P_r = \frac{GP}{4\pi^2}$$

An isotropic radiator with an input power equal to  $GP$  would produce the same flux density. Hence, this product is referred to as the EIRP, or EIRP is often expressed in decibels relative to 1 W, or dBW. Let  $PS$  be in watts; then  $[EIRP] = [PS] + [G]$  dB, where  $[PS]$  is also in dBW and  $[G]$  is in dB.

### Transmission Losses

The  $[EIRP]$  may be thought of as the power input to one end of the transmission link, and the problem is to find the power received at the other end. Losses will occur along the way, some of which are constant. Other losses can only be estimated from statistical data, and some of these are dependent on weather conditions, especially on rainfall.

The first step in the calculations is to determine the losses for *clear-weather* or *clear-sky conditions*. These calculations take into account the losses, including those calculated on a statistical basis which

does not vary with time. Losses which are weather-related, and other losses which fluctuate with time, are then allowed for by introducing appropriate *fade margins* into the transmission equation.



### **Free-space transmission:**

As a first step in the loss calculations, the power loss resulting from the spreading of the signal in space must be determined.

### **Feeder losses:**

Losses will occur in the connection between the receive antenna and the receiver proper. Such losses will occur in the connecting waveguides, filters, and couplers. These will be denoted by RFL, or [RFL] dB, for *receiver feeder losses*.

### **Antenna misalignment losses:**

When a satellite link is established, the ideal situation is to have the earth station and satellite antennas aligned for maximum gain, as shown in Figure 2.14. There are two possible sources of off-axis loss, one at the satellite and one at the earth station. The off-axis loss at the satellite is taken into account by designing the link for operation on the actual satellite antenna contour; this is described in more detail in later sections. The off-axis loss at the earth station is referred to as the *antenna pointing loss*. Antenna pointing losses are usually only a few tenths of a decibel. In addition to pointing losses, losses may result at the antenna from misalignment of the polarization direction. The polarization misalignment losses are usually small, and it will be assumed that the antenna misalignment losses, denoted by [AML], include both pointing and polarization losses resulting from antenna misalignment.

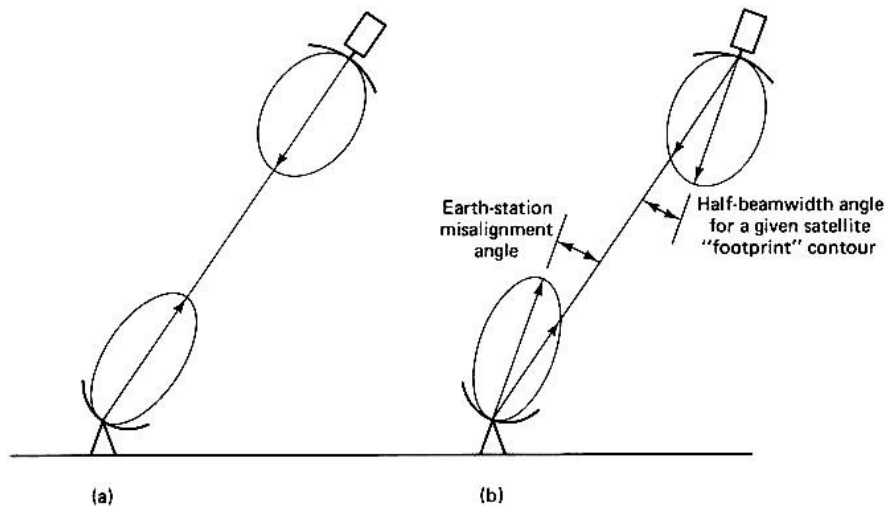

**Fig 2.14** (a) Satellite and earth-station antennas aligned for maximum gain; (b) earth station situated on a given satellite “footprint,” and earth-station antenna misaligned.

## The Link-Power Budget Equation

The losses for the link have been identified, the power at the receiver, which is the power output of the link, may be calculated simply as  $[EIRP] [LOSSES] [GR]$ , where the last quantity is the receiver antenna gain. The major source of loss in any ground-satellite link is the free-space spreading loss  $[FSL]$ , the basic link-power budget equation taking into account this loss only. However, the other losses also must be taken into account, and these are simply added to  $[FSL]$ .

The losses for clear-sky conditions are

$[LOSSES] = [FSL] + [RFL] + [AML] + [AA] - [PL]$  equation for the received power is then  $[PR] = [EIRP] \times [GR] - [LOSSES]$

Where

$[PR]$  - the received power, dBW

$[EIRP]$  - equivalent isotropic radiated power, dBW  $[FSL]$  free-space spreading loss, dB  $[RFL]$  - receiver feeder loss, dB

$[AML]$  - antenna misalignment loss, dB

$[AA]$  - atmospheric absorption loss, dB  $[PL]$  polarization mismatch loss, dB



## 2.8.1 Amplifier Noise Temperature

Consider first the noise representation of the antenna and the *low noise amplifier* (LNA) shown in Fig. 2.15. The available power gain of the amplifier is denoted as  $G$ , and the noise power output, as  $P_{no}$ .

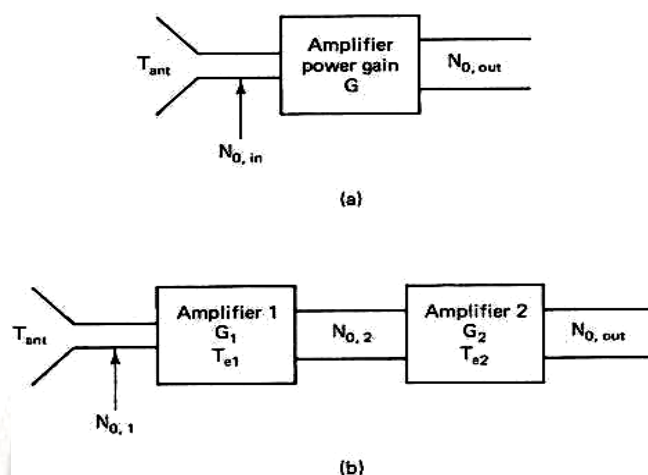

Fig 2.15 LNA Amplifier Gain

For the moment, the noise power per unit bandwidth, which is simply noise energy in joules as shown by the following Equation. The input noise energy coming from the antenna is

$$N_{0,ant} = kT_{ant}$$

## The Uplink

The uplink of a satellite circuit is the one in which the earth station is transmitting the signal and the satellite is receiving it specifically that the uplink is being considered.

$$\frac{C}{N} = [EIRP] - [LOSSES] + [k]$$

In the above equation, the values to be used are the earth station EIRP, the satellite receiver feeder losses, and satellite receiver  $G/T$ . The free-space loss and other losses which are frequency-dependent are calculated for the uplink frequency.

## Input back-off

Since the number of carriers are present simultaneously in a TWTA, the operating point must be backed off to a linear portion of the transfer characteristic to reduce the effects of inter modulation distortion. Such multiple carrier operation occurs with *frequency- division multiple access* (FDMA). The point to be made here is that *backoff* (BO) must be allowed for in the link- budget calculations. Suppose that the saturation flux density for single-carrier operation is known. Input BO will be specified for multiple-carrier operation, referred to the single- carrier saturation level.

The earth-station EIRP will have to be reduced by the specified BO,

$$\text{resulting in an uplink value of } [EIRP]_U = [EIRPS]_U + [BO]_i$$

## The earth station HPA

The earth station HPA has to supply the radiated power plus the transmit feeder losses, denoted here by TFL, or [TFL] dB. These include waveguide, filter, and coupler losses between the HPA output and the transmit antenna. The earth station may have to transmit multiple carriers and its output also will require back off, denoted by [BO]HPA. The earth station HPA must be rated for a saturation power output given by

$$[P_{HPA,sat}] = [P_{HPA}] + [BO]_{HPA}$$

## Downlink

The downlink of a satellite circuit is the one in which the satellite is transmitting the signal and the earth station is receiving it. Equation can be applied to the downlink, but subscript *D* will be used to denote specifically that the downlink is being considered.

$$\frac{C}{N} = [EIRP] - [LOSSES] + [k]$$



In the above equation, the values to be used are the satellite EIRP, the earth-station receiver feeder losses, and the earth-station receiver  $G/T$ . The free space and other losses are calculated for the downlink frequency. The resulting carrier-to-noise density ratio appears at the detector of the earth station receiver.

### Output back-off

Where input BO is employed as described in a corresponding output BO must be allowed for in the satellite EIRP. As the curve of Figure 2.16 shows that output BO is not linearly related to input BO. A rule of thumb, frequently used, is to take the output BO as the point on the curve which is 5 dB below the extrapolated linear portion. Since the linear portion gives a 1:1 change in decibels, the relationship between input and output BO is  $[BO]_0 = [BO]_i - 5 \text{ dB}$ . For example, with an input BO of  $[BO]_i = 11 \text{ dB}$ , the corresponding output BO is  $[BO]_0$

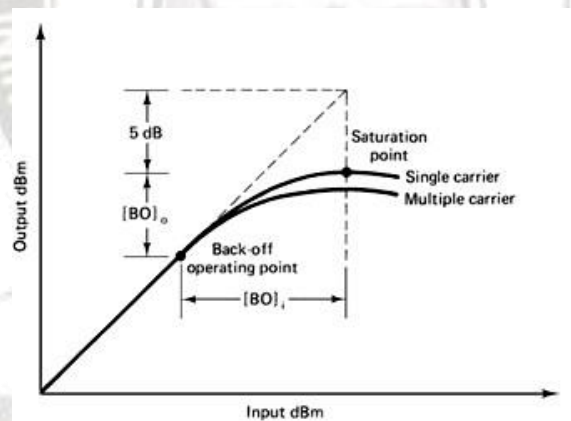

Fig 2.16 Input and output back-off relationship for the satellite traveling-wave-tube amplifier

### Effects of Rain

In the C band and, more especially, the Ku band, rainfall is the most significant cause of signal fading. Rainfall results in attenuation of radio waves by scattering and by absorption of energy from the wave. Rain attenuation increases with increasing frequency and is worse in the Ku band compared with the C band. This produces a depolarization of the wave; in effect, the wave becomes elliptically polarized. This is true for both linear and circular polarizations, and the effect seems to be much worse for circular polarization. The  $C/N_0$  ratio for the downlink

alone, not counting the  $P_{NU}$  contribution, is  $P_R/P_{ND}$ , and the combined  $C/N_0$  ratio at the ground receiver is

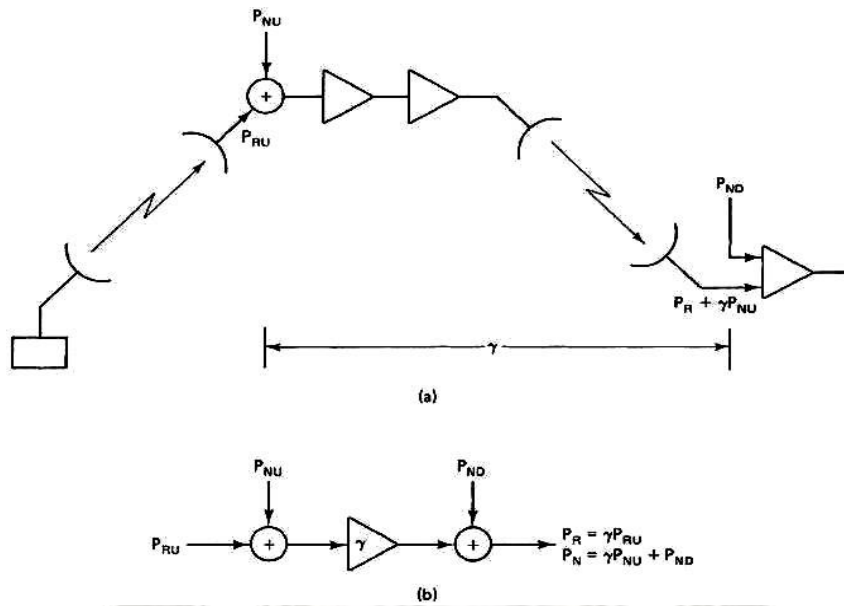

Fig 2.17 (a) Combined uplink and downlink (b) power flow diagram

The reason for this reciprocal of the sum of the reciprocals method is that a single signal power is being transferred through the system, while the various noise powers, which are present are additive. Similar reasoning applies to the carrier-to-noise ratio,  $C/N$ .

## Inter-modulation and Interference

Inter-modulation interference is the undesired combining of several signals in a nonlinear device, producing new, unwanted frequencies which can cause interference in adjacent receivers located at repeater sites. Not all interference is a result of inter-modulation distortion. It can come from co-channel interference, atmospheric conditions as well as man-made noise generated by medical, welding and heating equipment.

Most inter-modulation occurs in a transmitter's nonlinear power amplifier (PA). The next most common mixing point is in the front end of a receiver. Usually it occurs in the unprotected first mixer of older model radios or in some cases an overdriven RF front-end amp.

Inter-modulation can also be produced in rusty or corroded tower joints, guy wires, turnbuckles and anchor rods or any nearby metallic object, which can act as a nonlinear "mixer/rectifier" device.