

1.1 INSTRUMENTATION AMPLIFIER

In a number of industrial and consumer applications, one is required to measure and control physical quantities. Some typical examples are measurement and control of temperature, humidity, light intensity, water flow etc. these physical quantities are usually measured with help of transducers. The output of transducer has to be amplified so that it can drive the indicator or display system. This function is performed by an instrumentation amplifier. The important features of an instrumentation amplifier are

1. High gain accuracy
2. High CMRR
3. High gain stability with low temperature coefficient
4. Low output impedance

There are specially designed op-amps such as $\mu A725$ to meet the above stated requirements of a good instrumentation amplifier. Monolithic (single chip) instrumentation amplifier are also available commercially such as AD521, AD524, AD620, AD624 by Analog Devices, LM363.XX (XX \rightarrow 10, 100, 500) by National Semiconductor and INA101, 104, 3626, 3629 by Burr Brown. Figure 1.1.1 shows the Differential Amplifier using single op-amp.

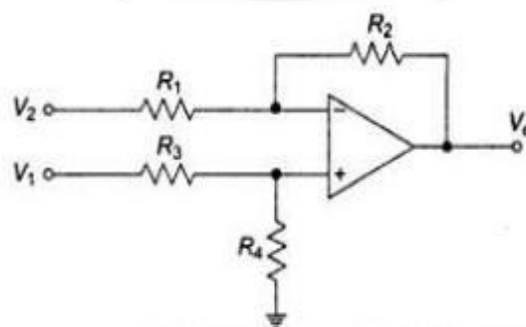

Figure 1.1.1 Differential Amplifier using single op-amp

[source: "Linear Integrated Circuits" by D.Roy Choudhry, Shail Bala Jain, Page-158]

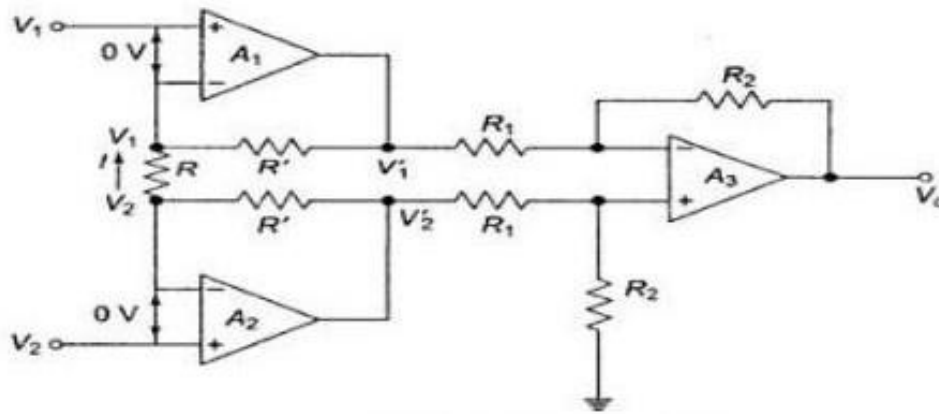

Figure 1.1.2 An improved Instrumentation Amplifier

[source: "Linear Integrated Circuits" by D.Roy Choudhry, Shail Bala Jain, Page-158]

Figure 1.1.2 shows the improved instrumentation amplifier using three op-amp. The output V_o is given by

$$V_o = \frac{R_2}{R_1} [V_1 - V_2]$$

Voltage at the + input terminal of op-amp A3 is

$$\frac{R_2 V_1'}{R_1 + R_2}$$

Using superposition Theorem

$$V_o = -\frac{R_2}{R_1} (V_1' - V_2') \quad \text{--- (1)}$$

Since no current flows into op-amp, the current I flowing (upwards) in R is

$$I = \frac{V_1 - V_2}{R}$$

And passes through the resistor R'

$$V_1' = R'I + V_1$$

$$V_1' = \frac{R'}{R} (V_1 - V_2) + V_1 \quad \text{--- (2)}$$

$$V_2' = R'I + V_2$$

$$V_2' = -\frac{R'}{R} (V_1 - V_2) + V_2 \text{ --- (3)}$$

Sub (2) & (3) in (1)

$$V_o = -\frac{R_2}{R_1} \left[\left(1 + \frac{2R'}{R} \right) (V_1 - V_2) \right]$$

In the circuit of figure source V_1 sees an input impedance = $R_3 + R_4$ (=101K) and the impedance seen by source V_2 is only R_1 (1K). This low impedance may load the signal source heavily. Therefore, high resistance buffer is used preceding each input to avoid this loading effect as shown in figure a

The op-amp A1 and A2 have differential input voltage as zero. For $V_1 = V_2$, that is, under common mode condition, the voltage across R will be zero. As no current flows through R and R' the non-inverting amplifier.

A_1 acts as voltage follower, so its output $V_2' = V_2$. Similarly op-amp A_2 acts as voltage follower having output $V_1' = V_1$. However, if $V_1 \neq V_2$, current flows in R and R' , and $(V_2' - V_1') > (V_2 - V_1)$. Therefore, this circuit has differential gain and CMRR more compared to the single op- amp circuit of figure 1.1.2.

The difference gain of this instrumentation amplifier R , however should never be made zero, as this will make the gain infinity. To avoid such a situation, in a practical circuit, a fixed resistance in series with a potentiometer is used in place of R .

Figure 1.1.3 shows a differential instrumentation amplifier using Transducer Bridge. The circuit uses a resistive transducer whose resistance changes as a function of the physical quantity to be measured.

The bridge is initially balanced by a dc supply voltage V_{dc} so that $V_1 = V_2$. As the physical quantity changes, the resistance R_T of the transducer also changes, causing an unbalance in the bridge ($V_1 \neq V_2$). This differential voltage now gets amplified by the three op-amp differential instrumentation amplifier.

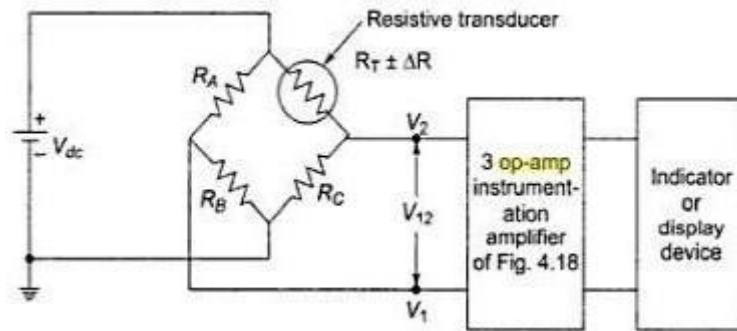

Figure 1.1.3 Instrumentation Amplifier using transducer bridge

[source: "Linear Integrated Circuits" by D.Roy Choudhry, Shail Bala Jain, Page-158]

APPLICATIONS OF INSTRUMENTATION AMPLIFIER WITH THE TRANSDUCER BRIDGE

- Temperature Indicator
- Temperature Controller
- Light Intensity Meter