



### DEPARTMENT OF ELECTRONICS AND COMMUNICATION ENGINEERING

#### BM3491 Biomedical Instrumentation

#### UNIT-III BIOAMPLIFIERS

#### 3.2 Single ended amplifier - Band pass filtering

##### 3.2.1 Single Ended amplifier:

A single-ended amplifier is a type of electronic amplifier that processes signals in a single direction. In other words, it amplifies signals only in one phase of the input signal waveform. The opposite of a single-ended amplifier is a differential amplifier, which amplifies the difference between two input signals.

For ease of drawing complex circuit diagrams, electronic amplifiers are often symbolized by a simple triangle shape, where the internal components are not individually represented. This symbology is very handy for cases where an amplifier's construction is irrelevant to the greater function of the overall circuit, and it is worthy of familiarization:

General amplifier circuit symbol

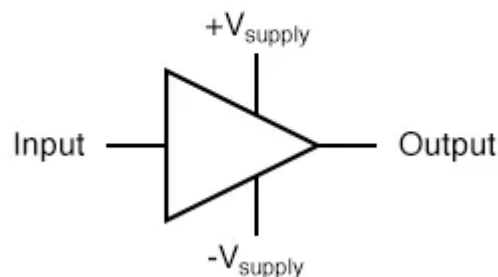

The +V and -V connections denote the positive and negative sides of the DC power supply, respectively. The input and output voltage connections are shown as single conductors, because it is assumed that all signal voltages are referenced to a common connection in the circuit called *ground*. Often (but not always!), one pole of the DC power supply, either positive or negative, is that ground reference point. A practical

amplifier circuit (showing the input voltage source, load resistance, and power supply) might look like this:

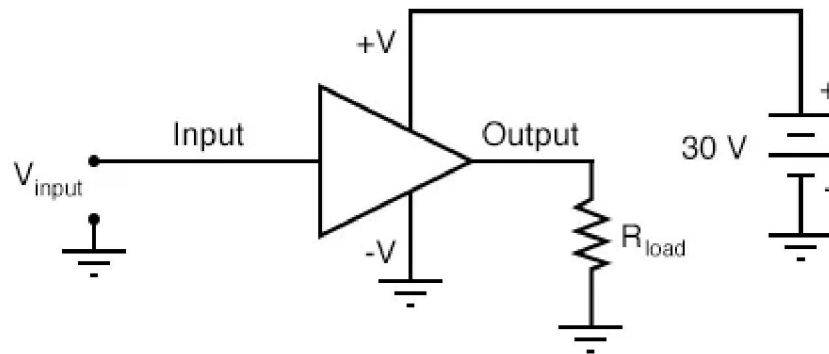

### 3.2.2 Band Pass filtering:

The **Passive Band Pass Filter** can be used to isolate or filter out certain frequencies that lie within a particular band or range of frequencies. The cut-off frequency or  $f_c$  point in a simple RC passive filter can be accurately controlled using just a single resistor in series with a non-polarized capacitor, and depending upon which way around they are connected, we have seen that either a Low Pass or a High Pass filter is obtained.

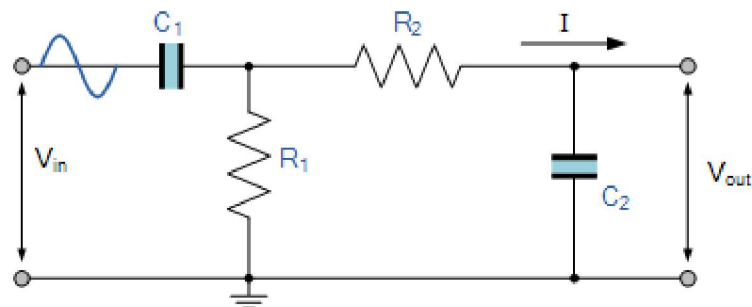

Unlike the low pass filter which only pass signals of a low frequency range or the high pass filter which pass signals of a higher frequency range, a **Band Pass Filters** passes signals within a certain “band” or “spread” of frequencies without distorting the input signal or introducing extra noise. This band of frequencies can be any width and is commonly known as the filters **Bandwidth**.

Bandwidth is commonly defined as the frequency range that exists between two specified frequency cut-off points ( $f_c$ ), that are 3dB below the maximum centre or resonant peak while attenuating or weakening the others outside of these two points.

Then for widely spread frequencies, we can simply define the term “bandwidth”, BW as being the difference between the lower cut-off frequency ( $f_{\text{LOWER}}$ ) and the higher cut-off frequency ( $f_{\text{HIGHER}}$ ) points. In other words,  $BW = f_H - f_L$ . Clearly for a pass band filter to function correctly, the cut-off frequency of the low pass filter must be higher than the cut-off frequency for the high pass filter.

Well-designed bandpass filters are generally used for both transmitting and receiving applications by using optimum bandwidth for the speed and mode of communication. This also maximizes the number of signals to be transferred in a system and minimizes the interference among the signals.

### RLC Band Pass Filter

As the name suggests RLC, this band pass filter contains only resistor, inductor and capacitor. This is also a passive band pass filter.

According to the connection of RLC, there are two circuit configurations of the RLC band pass filter. In the first configuration, the series LC circuit is connected in series with the load resistor. And the second configuration is parallel LC circuit is connected in parallel with a load resistor.

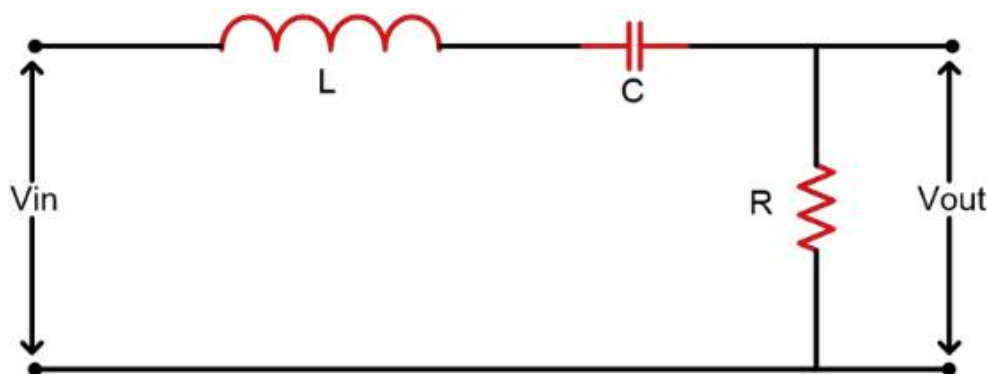

Circuit Diagram of RLC Band Pass Filter

A typical bandpass filter has two main parameters:

1. **Center Frequency ( $f_0$ ):** This is the midpoint or central frequency within the desired passband. It defines the frequency around which the filter allows maximum signal transmission.
2. **Bandwidth (BW):** The bandwidth is the range of frequencies that the filter permits to pass through. It is usually specified as the difference between the upper and lower -3 dB cutoff frequencies ( $f_1$  and  $f_2$ ), where the signal power is reduced to half (-3 dB) of its maximum value. In other words, the bandwidth defines how wide the passband is.

### **Band Pass Filter Applications:**

The application of band pass filter is as follows,

- Band pass filters are widely used in audio amplifier circuits. For example, the speaker is used to play only a desired range of frequencies and ignore the rest of the frequencies.
- It is used optics like LASER, LIDARS, etc.
- These filters are used in a communication system for choosing the signals with a particular bandwidth.
- It is used in audio signal processing.
- It is also used to optimize the signal to noise ratio and sensitivity of the receiver.

\*\*\*\*\*