



**ROHINI** COLLEGE OF ENGINEERING & TECHNOLOGY

Near Anjugramam Junction, Kanyakumari Main Road, Palkulam, Variyoor P.O - 629401  
Kanyakumari Dist, Tamilnadu., E-mail : [admissions@rcet.org.in](mailto:admissions@rcet.org.in), Website : [www.rcet.org.in](http://www.rcet.org.in)

**DEPARTMENT OF MECHANICAL ENGINEERING**



# **ME3491 THEORY OF MACHINES**

**COURSE MATERIAL**

## UNIT I KINEMATICS OF MECHANISMS

### 1.1 Introduction:

Link or Element, Pairing of Elements with degrees of freedom, Grubler's criterion (without derivation), Kinematic chain, Mechanism, Mobility of Mechanism, Inversions, Machine.

#### 1.1.1 Kinematic Chains and Inversions:

Kinematic chain with three lower pairs, Four bar chain, Single slider crank chain and Double slider crank chain and their inversions.

#### 1.1.2 Terminology and Definitions-Degree of Freedom, Mobility

- **Kinematics:** The study of motion (position, velocity, acceleration). A major goal of understanding kinematics is to develop the ability to design a system that will satisfy specified motion requirements. This will be the emphasis of this class.
- **Kinetics:** The effect of forces on moving bodies. Good kinematic design should produce good kinetics.
- **Mechanism:** A system design to transmit motion. (low forces)
- **Machine:** A system designed to transmit motion and energy. (forces involved)
- **Basic Mechanisms:** Includes geared systems, cam-follower systems and linkages (rigid links connected by sliding or rotating joints). A mechanism has multiple moving parts (for example, a simple hinged door does not qualify as a mechanism).

#### 1.1.3 Key concepts:

- **Degrees of freedom:** The number of inputs required to completely control a system.  
**Examples:** A simple rotating link. A two-link system. A four-bar linkage. A five-bar linkage.
- **Types of motion:** Mechanisms may produce motions that are pure rotation, pure translation, or a combination of the two. We reduce the degrees of freedom of a mechanism by restraining the ability of the mechanism to move in translation (x-y directions for a 2D mechanism) or in rotation (about the z-axis for a 2-D mechanism).
- **Link:** A rigid body with two or more nodes (joints) that are used to connect to other rigid bodies. (WM examples: binary link, ternary link (3 joints), quaternary link (4 joints))
- **Joint:** A connection between two links that allows motion between the links. The motion allowed may be rotational (revolute joint), translational (sliding or prismatic joint), or a combination of the two (roll-slide joint).
- **Kinematic chain:** An assembly of links and joints used to coordinate an output motion with an input motion.
- **Link or element:**

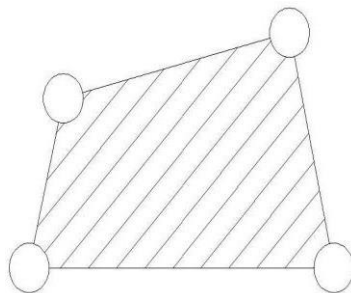

A mechanism is made of a number of resistant bodies out of which some may have motions relative to the others. A resistant body or a group of resistant bodies with rigid connections preventing their relative movement is known as a link.

A link may also be defined as a member or a combination of members of a mechanism, connecting other members and having motion relative to them, thus a link may consist of one or more resistant bodies. A link is also known as Kinematic link or an element.

Links can be classified into 1) Binary, 2) Ternary, 3) Quaternary, etc.

#### □ **Kinematic Pair:**

A Kinematic Pair or simply a pair is a joint of two links having relative motion between them.

#### **1.1.4 Types of Kinematic Pairs:**

Kinematic pairs can be classified according to

- i) Nature of contact.
- ii) Nature of mechanical constraint.
- iii) Nature of relative motion.

##### **i) Kinematic pairs according to nature of contact:**

a) Lower Pair: A pair of links having surface or area contact between the members is known as a lower pair. The contact surfaces of the two links are similar.

Examples: Nut turning on a screw, shaft rotating in a bearing, all pairs of a slider-crank mechanism, universal joint.

b) Higher Pair: When a pair has a point or line contact between the links, it is known as a higher pair. The contact surfaces of the two links are dissimilar.

Examples: Wheel rolling on a surface cam and follower pair, tooth gears, ball and roller bearings, etc.

##### **ii) Kinematic pairs according to nature of mechanical constraint.**

a) Closed pair: When the elements of a pair are held together mechanically, it is known as a closed pair. The contact between the two can only be broken only by the destruction of at least one of the members. All the lower pairs and some of the higher pairs are closed pairs.

b) Unclosed pair: When two links of a pair are in contact either due to force of gravity or some spring action, they constitute an unclosed pair. In this the links are not held together mechanically. Ex.: Cam and follower pair.

##### **iii) Kinematic pairs according to nature of relative motion.**

a) Sliding pair: If two links have a sliding motion relative to each other, they form a sliding pair. A rectangular rod in a rectangular hole in a prism is an example of a sliding pair.

b) Turning Pair: When on link has a turning or revolving motion relative to the other, they constitute a turning pair or revolving pair.

c) Rolling pair: When the links of a pair have a rolling motion relative to each other, they form a rolling pair. A rolling wheel on a flat surface, ball and roller bearings, etc are some of the examples for a Rolling pair.

d) Screw pair (Helical Pair): if two mating links have a turning as well as sliding motion between them, they form a screw pair. This is achieved by cutting matching threads on the two links.

The lead screw and the nut of a lathe is a screw Pair

e) Spherical pair: When one link in the form of a sphere turns inside a fixed link, it is a spherical pair. The ball and socket joint is a spherical pair.

#### **1.2 Degrees of Freedom:**

An unconstrained rigid body moving in space can describe the following independent motions.

1. Translational Motions along any three mutually perpendicular axes x, y and z,
2. Rotational motions along these axes.

To find the number of degrees of freedom for a plane mechanism we have an equation known as

**Grubler's equation and is given by  $F = 3(n - 1) - 2j_1 - j_2$**

$F$  = Mobility or number of degrees of freedom,  $n$  = Number of links including frame.  
 $J_1$  = Joints with single (one) degree of freedom,  $J_2$  = Joints with two degrees of freedom.  
 If  $F > 0$ , results in a mechanism with „ $F$ “ degrees of freedom.  
 $F = 0$ , results in a statically determinate structure.  
 $F < 0$ , results in a statically indeterminate structure.

### 1.2.1 Kinematic Chain:

A Kinematic chain is an assembly of links in which the relative motions of the links is possible and the motion of each relative to the others is definite (fig. a, b, and c.)

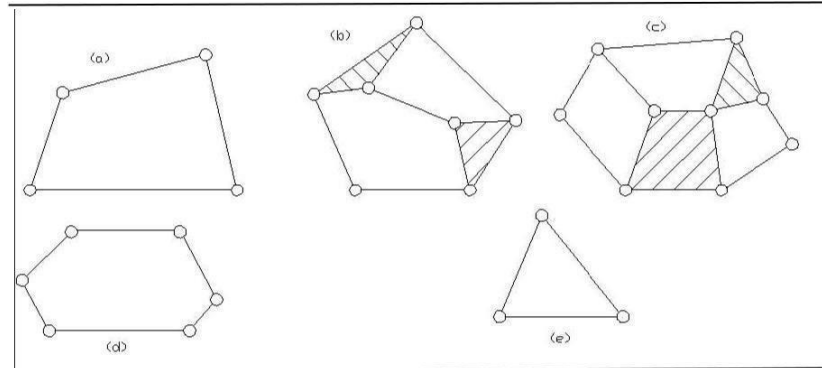

In case, the motion of a link results in indefinite motions of other links, it is a non-kinematic chain. However, some authors prefer to call all chains having relative motions of the links as kinematic chains.

### 1.2.2 Linkage, Mechanism and structure:

- A linkage is obtained if one of the links of kinematic chain is fixed to the ground. If motion of each link results in definite motion of the others, the linkage is known as mechanism.
- If one of the links of a redundant chain is fixed, it is known as a structure.

**The three main types of constrained motion in kinematic pair are,**

**1. Completely constrained motion:** If the motion between a pair of links is limited to a definite direction, then it is completely constrained motion.

**2. Incompletely Constrained motion :** If the motion between a pair of links is not confined to a definite direction, then it is incompletely constrained motion

**3. Successfully constrained motion or Partially constrained motion:** If the motion in a definite direction is not brought about by itself but by some other means, then it is known as successfully constrained motion.

### Machine:

It is a combination of resistant bodies with successfully constrained motion which is used to transmit or t

### 1.3. Kutzbach criterion, Grashoff's law

**Kutzbach criterion:**

- **Fundamental Equation for 2-D Mechanisms:**  $M = 3(L - 1) - 2J_1 - J_2$

**Can we intuitively derive Kutzbach's modification of Grubler's equation?** Consider a rigid link constrained to move in a plane.

#### 1.3.1 Grashoff's law:

- **Grashoff 4-bar linkage:** A linkage that contains one or more links capable of undergoing a full rotation. A linkage is Grashoff if:  $S + L < P + Q$  (where:  $S$  = shortest link length,  $L$  = longest,  $P$ ,  $Q$  = intermediate length links).
- **Non Grashoff 4 bar:** No link can rotate 360 if:  $S + L > P + Q$

## Inversions:

By fixing each link at a time we get as many mechanisms as the number of links, then each mechanism is called „Inversion“ of the original Kinematic Chain.

### Inversions of four bar chain mechanism:

There are three inversions: 1) Beam Engine or Crank and lever mechanism. 2) Coupling rod of locomotive or double crank mechanism. 3) Watt's straight-line mechanism or double lever mechanism.

#### 1. Beam Engine: - 1<sup>st</sup> Inversion or 3<sup>rd</sup> Inversion

When the crank AB rotates about A, the link CE pivoted at D makes vertical reciprocating motion at end E. This is used to convert rotary motion to reciprocating motion and vice versa. It is also known as Crank and lever mechanism.

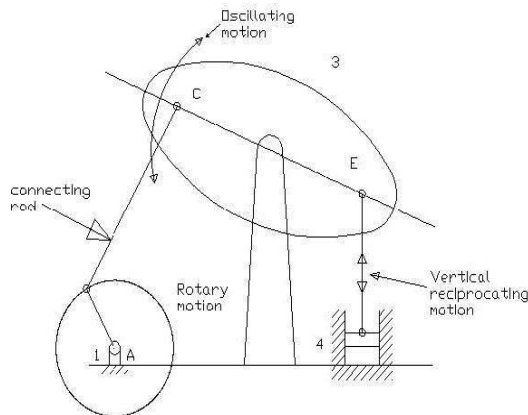

#### 2. Coupling rod of locomotive:

In this mechanism the length of link AD = length of link C. Also, length of link AB = length of link CD. When AB rotates about A, the crank DC rotates about D. this mechanism is used for coupling locomotive wheels. Since links AB and CD work as cranks, this mechanism is also known as double crank mechanism. This is shown in the figure below.

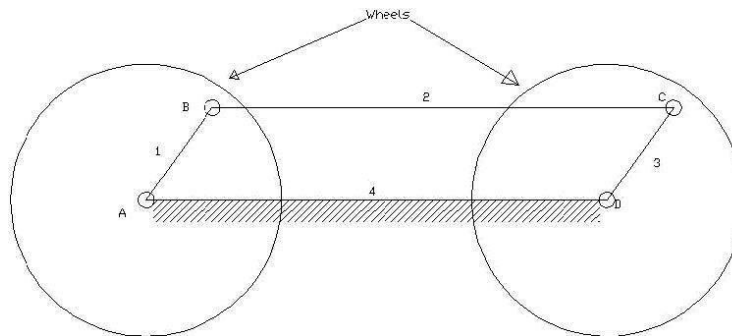

3. **Watt's straight-line mechanism or Double lever mechanism:** In this mechanism, the links AB & DE act as levers at the ends A & E of these levers are fixed. The AB & DE are parallel in the mean position of the mechanism and coupling rod BD is perpendicular to the levers AB & DE. On any small displacement of the mechanism the tracing point „C“ traces the shape of number „8“, a

portion of which will be approximately straight. Hence this is also an example for the approximate straight-line mechanism. This mechanism is shown below.

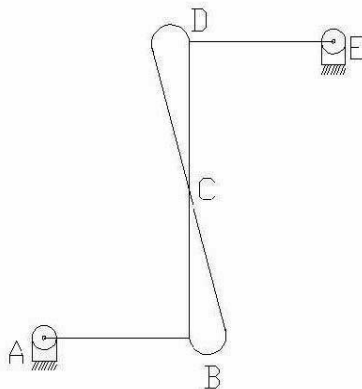

□ **2. Slider crank Chain:**

It is a four-bar chain having one sliding pair and three turning pairs. It is shown in the figure below the purpose of this mechanism is to convert rotary motion to reciprocating motion and vice versa. Inversions of a Slider crank chain:

**There are four inversions in a single slider chain mechanism. They are:**

**1. Reciprocating engine mechanism:**

In the first inversion, the link 1 i.e., the cylinder and the frame are kept fixed. The fig below shows a reciprocating engine.

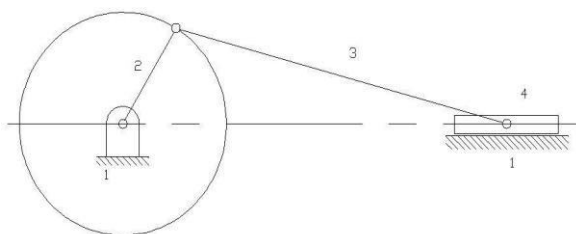

A slotted link 1 is fixed. When the crank 2 rotates about O, the sliding piston 4 reciprocates in the slotted link 1. This mechanism is used in steam engine, pumps, compressors, I.C. engines, etc.

**2. Crank and slotted lever mechanism:**

It is an application of second inversion. The crank and slotted lever mechanism is shown in figure below.

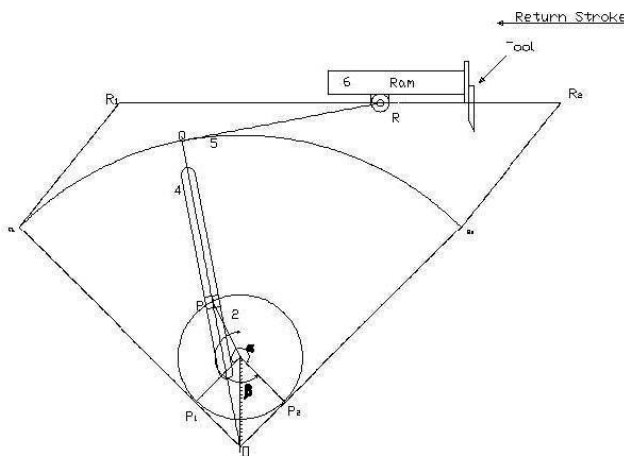

- In this mechanism link 3 is fixed. The slider (link 1) reciprocates in oscillating slotted lever (link 4) and crank (link 2) rotates. Link 5 connects link 4 to the ram (link 6).
- The ram with the cutting tool reciprocates perpendicular to the fixed link 3.
- The ram with the tool reverses its direction of motion when link 2 is perpendicular to link 4.
- Thus, the cutting stroke is executed during the rotation of the crank through angle  $\alpha$  and the return stroke is executed when the crank rotates through angle  $\beta$  or  $360 - \alpha$ . Therefore, when the crank rotates uniformly, we get

$$\frac{\text{Time to cutting}}{\text{Time of return}} = \frac{\alpha}{\beta} = \frac{\alpha}{360 - \alpha}$$

- This mechanism is used in shaping machines, slotting machines and in rotary engines.

#### 1.4.1 Whitworth quick return motion mechanism:

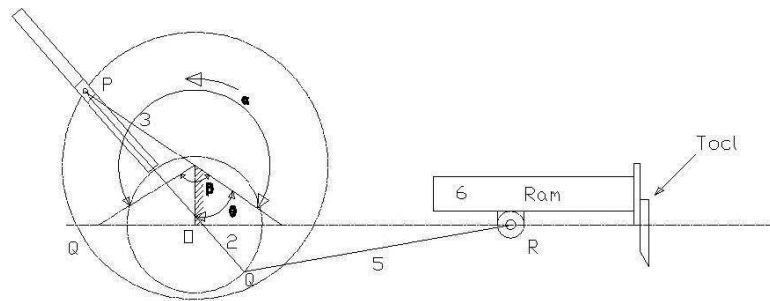

- Third inversion is obtained by fixing the crank i.e. link 2. Whitworth quick return mechanism is an application of third inversion.
- The crank OC is fixed and OQ rotates about O. The slider slides in the slotted link and generates a circle of radius CP. Link 5 connects the extension OQ provided on the opposite side of the link 1 to the ram (link 6).
- The rotary motion of P is taken to the ram R which reciprocates. The quick return motion mechanism is used in shapers and slotting machines.
- The angle covered during cutting stroke from P1 to P2 in counter clockwise direction is  $\alpha$  or  $360 - 2\theta$ . During the return stroke, the angle covered is  $2\theta$  or  $\beta$ .

#### 1. Rotary engine mechanism or Gnome Engine:

- Rotary engine mechanism or gnome engine is another application of third inversion. It is a rotary cylinder V – type internal combustion engine used as an aero – engine.
- The Gnome engine has generally seven cylinders in one plane. The crank OA is fixed and all the connecting rods from the pistons are connected to A.
- In this mechanism when the pistons reciprocate in the cylinders, the whole assembly of cylinders, pistons and connecting rods rotate about the axis O, where the entire mechanical power developed, is obtained in the form of rotation of the crank shaft. This mechanism is shown in the figure below.

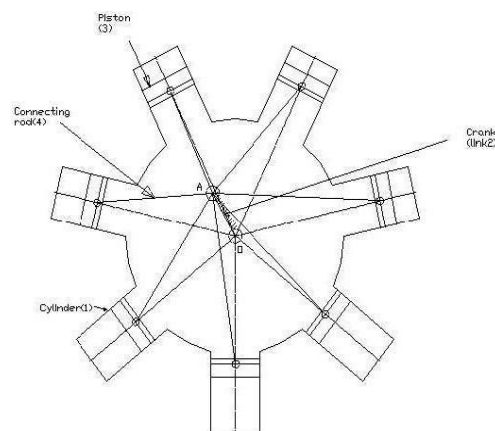

### Double Slider Crank Chain:

A four bar chain having two turning and two sliding pairs such that two pairs of the same kind are adjacent is known as double slider crank chain.

### 3 Inversions of Double slider Crank chain:

It consists of two sliding pairs and two turning pairs. They are three important inversions of double slider crank chain. 1) Elliptical trammel. 2) Scotch yoke mechanism. 3) Oldham's Coupling.

### 4. Elliptical Trammel:

This is an instrument for drawing ellipses. Here the slotted link is fixed. The sliding block P and Q in vertical and horizontal slots respectively. The end R generates an ellipse with the displacement of sliders P and Q.

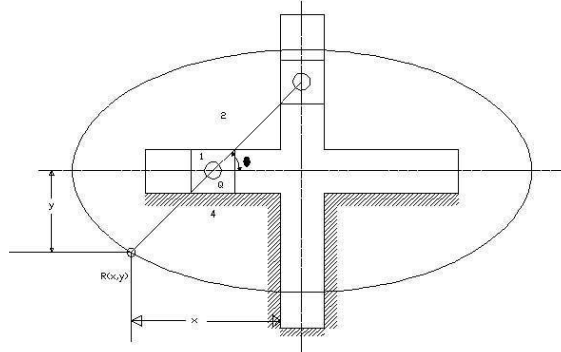

The co-ordinates of the point R are x and y. From the fig.  $\cos \theta = \frac{x}{PR}$  and  $\sin \theta = \frac{y}{QR}$

Squaring and adding (i) and (ii) we get  $x^2 + y^2 = PR^2 = QR^2 = r^2$

The equation is that of an ellipse, Hence the instrument traces an ellipse. Path traced by mid-point of it is an equation of circle with  $PR = QR =$  radius of a circle.

**5. Scotch yoke mechanism:** This mechanism, the slider P is fixed. When PQ rotates above P, the slider Q reciprocates in the vertical slot. The mechanism is used to convert rotary to reciprocating mechanism.

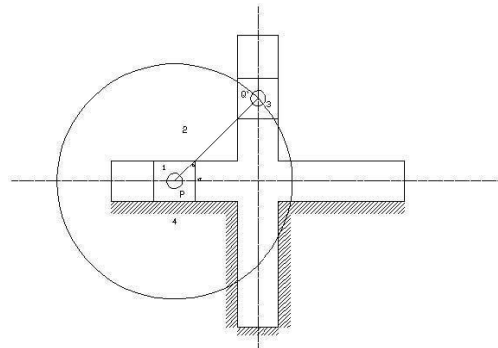

**5. Oldham's coupling:** The third inversion of obtained by fixing the link connecting the 2 blocks P & Q. If one block is turning through an angle, the frame and the other block will also turn through the same angle. It is shown in the figure below.

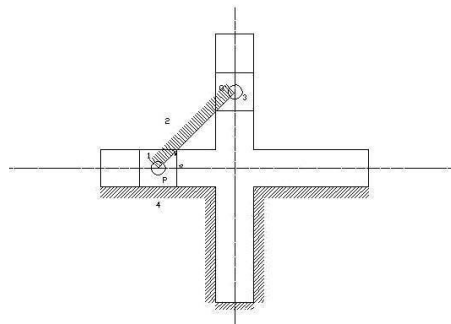

- An application of the third inversion of the double slider crank mechanism is Oldham's coupling shown in the figure. This coupling is used for connecting two parallel shafts when the distance between the shafts is small.



- The two shafts to be connected have flanges at their ends, secured by forging. Slots are cut in the flanges. These flanges form 1 and 3.
- An intermediate disc having tongues at right angles and opposite sides is fitted in between the flanges. The intermediate piece forms the link 4 which slides or reciprocates in flanges 1 & 3.
- The link two is fixed as shown. When flange 1 turns, the intermediate disc 4 must turn through the same angle and whatever angle 4 turns, the flange 3 must turn through the same angle.
- Hence 1, 4 & 3 must have the same angular velocity at every instant. If the distance between the axis of the shaft is  $x$ , it will be the diameter of the circle traced by the centre of the intermediate piece. The maximum sliding speed of each tongue along its slot is given by
  - $v = x\omega$  where,  $\omega$  = angular velocity of each shaft in rad/sec  $v$  = linear velocity in m/sec

### 1.6 Mechanical Advantage

The mechanical advantage (MA) is defined as the ratio of output torque to the input torque. (or) ratio of load to output.

#### Transmission angle.

The extreme values of the transmission angle occur when the crank lies along the line of frame.

### 1.7 Description of common mechanisms-Single, Double and offset slider mechanisms - Quick return mechanisms:

#### 1. Quick Return Motion Mechanisms:

Many times mechanisms are designed to perform repetitive operations. During these operations for a certain period the mechanisms will be under load known as working stroke and the remaining period is known as the return stroke, the mechanism returns to repeat the operation without load. The ratio of time of working stroke to that of the return stroke is known a time ratio.

Quick return mechanisms are used in machine tools to give a slow cutting stroke and a quick return stroke. The various quick return mechanisms commonly used are i) Whitworth ii) Drag link. iii) Crank and slotted lever mechanism

#### 2. Whitworth quick return mechanism:

- Whitworth quick return mechanism is an application of third inversion of the single slider crank chain. This mechanism is shown in the figure below.
- The crank OC is fixed and OQ rotates about O. The slider slides in the slotted link and generates a circle of radius CP. Link 5 connects the extension OQ provided on the opposite side of the link 1 to the ram (link 6). The rotary motion of P is taken to the ram R which reciprocates.
- The quick return motion mechanism is used in shapers and slotting machines.

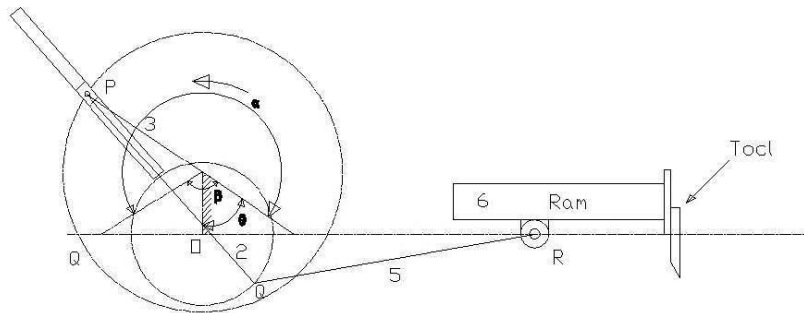

- The angle covered during cutting stroke from P1 to P2 in counter clockwise direction is  $\alpha$  or  $360 - 2\theta$ .
- During the return stroke, the angle covered is  $2\theta$  or  $\beta$ .

#### 3. Drag link mechanism:

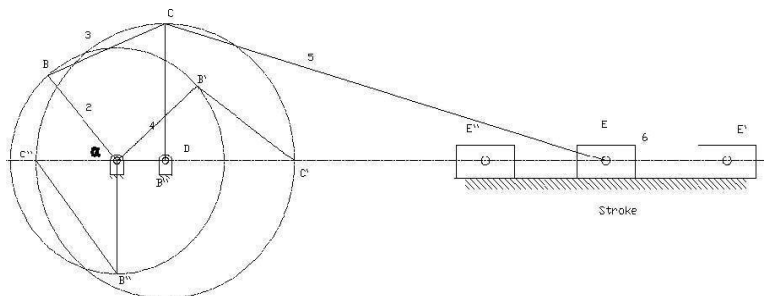

- This is four bar mechanism with double crank in which the shortest link is fixed. If the crank AB rotates at a uniform speed, the crank CD rotate at a non -uniform speed.
- This rotation of link CD is transformed to quick return reciprocatory motion of the ram E by the link CE as shown in figure.
- When the crank AB rotates through an angle  $\alpha$  in Counter clockwise direction during working stroke, the link CD rotates through  $180^\circ$ . We can observe that  $\alpha > \beta$ .
- Hence time of working stroke is  $\alpha / \beta$  times more or the return stroke is  $\alpha / \beta$  times quicker. Shortest link is always stationary link.
- Sum of the shortest and the longest links of the four links 1, 2, 3 and 4 are less than the sum of the other two. It is the necessary condition for the drag link quick return mechanism.

#### 4. Crank and slotted lever mechanism:

It is an application of second inversion. The crank and slotted lever mechanism is shown in figure below.

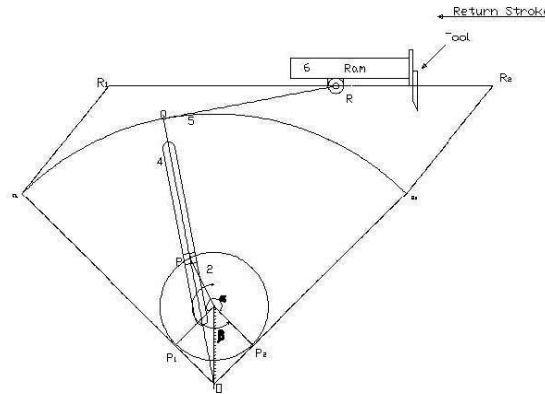

- In this mechanism link 3 is fixed. The slider (link 1) reciprocates in oscillating slotted lever (link 4) and crank (link 2) rotates. Link 5 connects link 4 to the ram (link 6).
- The ram with the cutting tool reciprocates perpendicular to the fixed link 3. The ram with the tool reverses its direction of motion when link 2 is perpendicular to link 4.
- Thus, the cutting stroke is executed during the rotation of the crank through angle  $\alpha$  and the return stroke is executed when the crank rotates through angle  $\beta$  or  $360 - \alpha$ . Therefore, when the crank rotates uniformly, we get,

#### 5. Ratchets and escapements - Indexing Mechanisms - Rocking Mechanisms:

##### Intermittent motion mechanism:

##### Ratchet and Pawl mechanism:

- This mechanism is used in producing intermittent rotary motion member. A ratchet and Pawl mechanism consist of a ratchet wheel 2 and a pawl 3 as shown in the figure.
- When the lever 4 carrying pawl is raised, the ratchet wheel rotates in the counter clock wise direction (driven by pawl). As the pawl lever is lowered the pawl slides over the ratchet teeth. One more pawl 5 is used to prevent the ratchet from reversing.
- Ratchets are used in feed mechanisms, lifting jacks, clocks, watches and counting devices.

6. **Geneva mechanism:** Geneva mechanism is an intermittent motion mechanism. It consists of a driving wheel D carrying a pin P which engages in a slot of follower F as shown in figure.

- During one quarter revolution of the driving plate, the Pin and follower remain in contact and hence the follower is turned by one quarter of a turn.
- During the remaining time of one revolution of the driver, the follower remains in rest locked in position by the circular arc.

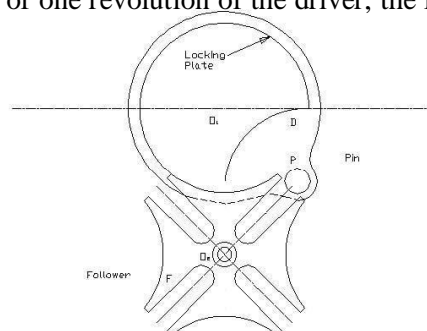

**7. Pantograph:** Pantograph is used to copy the curves in reduced or enlarged scales. Hence this mechanism finds its use in copying devices such as engraving or profiling machines.

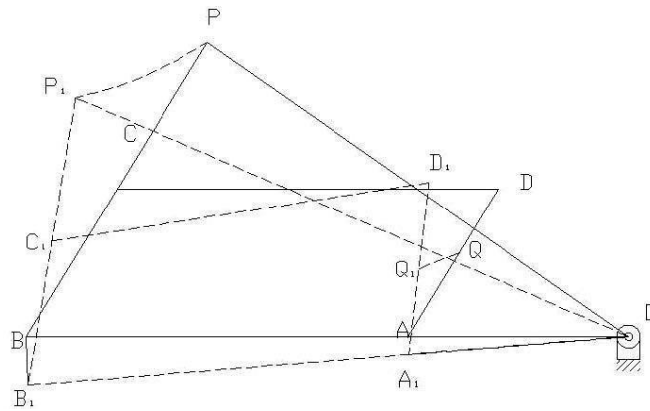

- This is a simple figure of a Pantograph. The links are pin jointed at A, B, C and D. AB is parallel to DC and AD is parallel to BC. Link BA is extended to fixed pin O. Q is a point on the link AD.
- If the motion of Q is to be enlarged then the link BC is extended to P such that O, Q and P are in a straight line. Then it can be shown that the points P and Q always move parallel and similar to each other over any path straight or curved.
- Their motions will be proportional to their distance from the fixed point. Let ABCD be the initial position. Suppose if point Q moves to Q1, then all the links and the joints will move to the new positions (such as A moves to A1, B moves to B1, C moves to C1, D moves to D1 and P to P1) and the new configuration of the mechanism is shown by dotted lines. The movement of Q (Q to Q1) will be enlarged to PP1 in a definite ratio.

### 8. Toggle Mechanism:

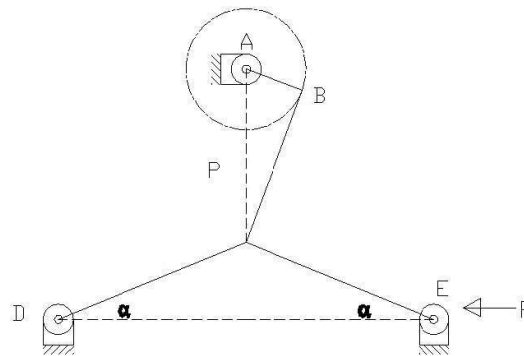

- In slider crank mechanism as the crank approaches one of its dead centre position, the slider approaches zero. The ratio of the crank movement to the slider movement approaching infinity is proportional to the mechanical advantage. This is the principle used in toggle mechanism.
- A toggle mechanism is used when large forces act through a short distance is required. The figure below shows a toggle mechanism. Links CD and CE are of same length. Resolving the forces at C vertically  **$F \sin \alpha = P \cos \alpha$**
- Therefore,  $F = P \cdot \frac{\cos \alpha}{\sin \alpha} = P \cdot \cot \alpha$ . Thus for the given value of P, as the links CD and CE approaches collinear position ( $\alpha \rightarrow 0$ ), the force F rises rapidly.

### 9. Hooke's joint:

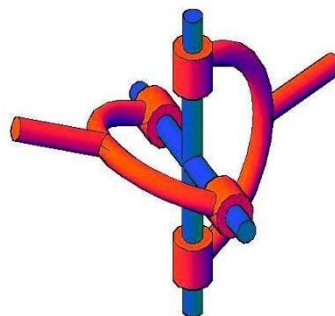

- Hooke's joint used to connect two parallel intersecting shafts as shown in figure. This can also be used for shaft with angular misalignment where flexible coupling does not serve the purpose.
- Hence Hooke's joint is a means of connecting two rotating shafts whose axes lie in the same plane and their directions making a small angle with each other.
- It is commonly known as Universal joint. In Europe it is called as Cardan joint.

### 10. Ackermann steering gear mechanism:

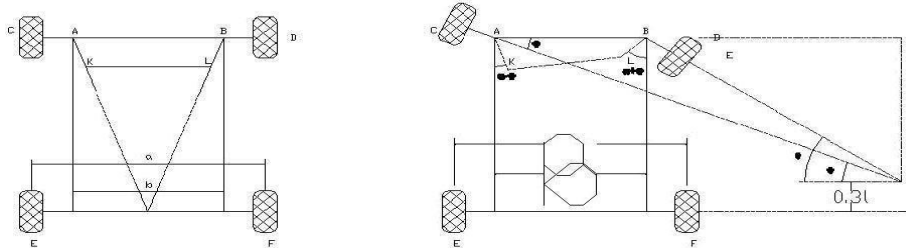

- This mechanism is made of only turning pairs and is made of only turning pairs wear and tear of the parts is less and cheaper in manufacturing.
- The cross-link KL connects two short axles AC and BD of the front wheels through the short links AK and BL which forms bell crank levers CAK and DBL respectively as shown in fig, the longer links AB and KL are parallel and the shorter links AK and BL are inclined at an angle  $\alpha$ .
- When the vehicles steer to the right as shown in the figure, the short link BL is turned so as to increase  $\alpha$ , whereas the link LK causes the other short link AK to turn so as to reduce  $\alpha$ . The fundamental equation for correct steering is,

$$\text{Cot}\Phi - \text{Cos}\theta = b / l$$

- In the above arrangement it is clear that the angle  $\Phi$  through which AK turns is less than the angle  $\theta$  through which the BL turns and therefore the left front axle turns through a smaller angle than the right front axle. For different angle of turn  $\theta$ , the corresponding value of  $\Phi$  and  $(\text{Cot}\Phi - \text{Cos}\theta)$  are noted.
- This is done by actually drawing the mechanism to a scale or by calculations. Therefore, for different value of the corresponding value of and are tabulated.

#### Three correct steering positions will be:

- 1) When moving straight.
- 2) When moving one correct angle to the right corresponding to the link ratio AK/AB and angle  $\alpha$ .
- 3) Similar position when moving to the left. **In all other positions pure rolling is not obtainable.**

#### ELLIPTICAL TRAMMEL

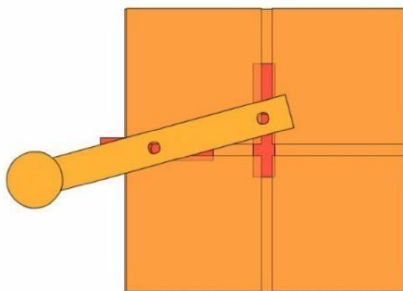

#### PISTON ARRANGEMENT

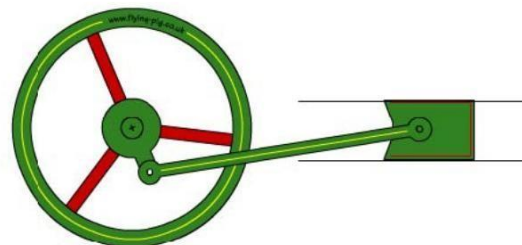

**ELLIPTICAL TRAMMEL:** This fascinating mechanism converts rotary motion to reciprocating motion in two axis. Notice that the handle traces out an ellipse rather than a circle. A similar mechanism is used in ellipse drawing tools.

**PISTON ARRANGEMENT:** This mechanism is used to convert between rotary motion and reciprocating motion, it works either way. Notice how the speed of the piston changes. The piston starts from one end, and increases its speed. It reaches maximum speed in the middle of its travel then gradually slows down until it reaches the end of its travel.

### RACK AND PINION

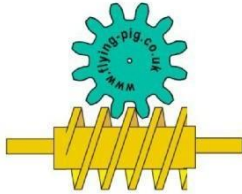

### RATCHET

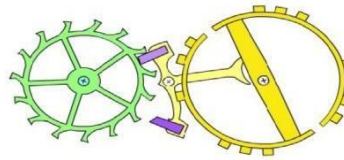

**RACK AND PINION:** The rack and pinion is used to convert between rotary and linear motion. The rack is the flat, toothed part, the pinion is the gear.

- Rack and pinion can convert from rotary to linear or from linear to rotary. The diameter of the gear determines the speed that the rack moves as the pinion turns.
- Rack and pinions are commonly used in the steering system of cars to convert the rotary motion of the steering wheel to the side to side motion in the wheels. Rack and pinion gears give a positive motion especially compared to the friction drive of a wheel in tarmac.
- In the rack and pinion railway a central rack between the two rails engages with a pinion on the engine allowing the train to be pulled up very steep slopes.

**RATCHET:** The ratchet can be used to move a toothed wheel one tooth at a time. The part used to move the ratchet is known as the pawl.

- The ratchet can be used as a way of gearing down motion. By its nature motion created by a ratchet is intermittent. By using two pawls simultaneously this intermittent effect can be almost, but not quite, removed.
- Ratchets are also used to ensure that motion only occurs in only one direction, useful for winding gear which must not be allowed to drop. Ratchets are also used in the freewheel mechanism of a bicycle.

### WORM GEAR



### WATCH ESCAPEMENT



## 1.8 Straight line generators, Design of Crank-rocker Mechanisms:

### □ Straight Line Motion Mechanisms:

The easiest way to generate a straight-line motion is by using a sliding pair but in precision machines sliding pairs are not preferred because of wear and tear. Hence in such cases different methods are used to generate straight line motion mechanisms:

#### 1. Exact straight-line motion mechanism.

a. Peaucellier mechanism, b. Hart mechanism, c. Scott Russell mechanism

#### 2. Approximate straight-line motion mechanisms

a. Watt mechanism, b. Grasshopper's mechanism, c. Robert's mechanism, d. Tchebicheff's mechanism

#### a. Peaucillier mechanism:

The pin Q is constrained to move long the circumference of a circle by means of the link OQ. The link OQ and the fixed link are equal in length. The pins P and Q are on opposite corners of a four-bar chain which has all four links QC, CP, PB and BQ of equal length to the fixed pin A. i.e., link AB = link AC. The product AQ x AP

remain constant as the link OQ rotates may be proved as follows: Join BC to bisect PQ at F; then, from the right angled triangles AFB, BFP, we have  $AB=AF+FB$  and  $BP=BF+FP$ . Subtracting,  $AB-BP= AF-FP=(AF-FP) (AF+FP) = AQ \times AP$ . Since AB and BP are links of a constant length, the product  $AQ \times AP$  is constant. Therefore, the point P traces out a straight path normal to AR.

**b. Robert’s mechanism:**

This is also a four bar chain. The link PQ and RS are of equal length and the tracing pint „O“ is rigidly attached to the link QR on a line which bisects QR at right angles. The best position for O may be found by making use of the instantaneous centre of QR. The path of O is clearly approximately horizontal in the Robert’s mechanism.

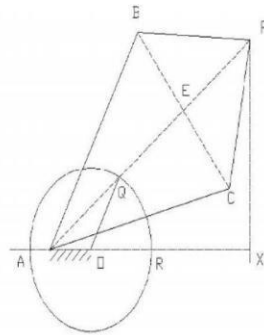

**a. Peaucillier mechanism**

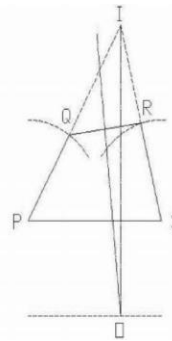

**b. Hart mechanism**