

**Fm Capture Effect:**

A phenomenon, associated with FM reception, in which only the stronger of two signals at or near the same frequency will be demodulated. The complete suppression of the weaker signal occurs at the receiver limiter, where it is treated as noise and rejected. When both signals are nearly equal in strength, or are fading independently, the receiver may switch from one to the other.

In the frequency modulation, the signal can be affected by another frequency modulated signal whose frequency content is close to the carrier frequency of the desired FM wave. The receiver may lock such an interference signal and suppress the desired FM wave when interference signal is stronger than the desired signal. When the strength of the desired signal and interference signal are nearly equal, the receiver fluctuates back and forth between them, i.e., receiver locks interference signal for some times and desired signal for some time and this goes on randomly. This phenomenon is known as the capture effect.

**Pre-Emphasis & De-Emphasis:**

Pre-emphasis refers to boosting the relative amplitudes of the modulating voltage for

**1. Pre-Emphasis Circuit:**

At the transmitter, the modulating signal is passed through a simple network which amplifies the high frequency, components more than the low-frequency components. The simplest form of such a circuit is a simple high pass filter of the type shown in fig (a). Specification dictate a time constant of 75 microseconds ( $\mu\text{s}$ ) where  $t = RC$ . Any combination of resistor and capacitor (or resistor and inductor) giving this time constant will be satisfactory. Such a circuit has a cutoff frequency  $f_{co}$  of 2122 Hz. This means that frequencies higher than 2122 Hz will be linearly enhanced. The output amplitude increases with frequency at a rate of 6 dB per octave. The pre-emphasis curve is shown in Figure 4.6.1 & 4.6.2. This pre-emphasis

circuit increases the energy content of the higher-frequency signals so that they will tend to become stronger than the high frequency noise components. This improves the signal to noise ratio and increases intelligibility and fidelity.

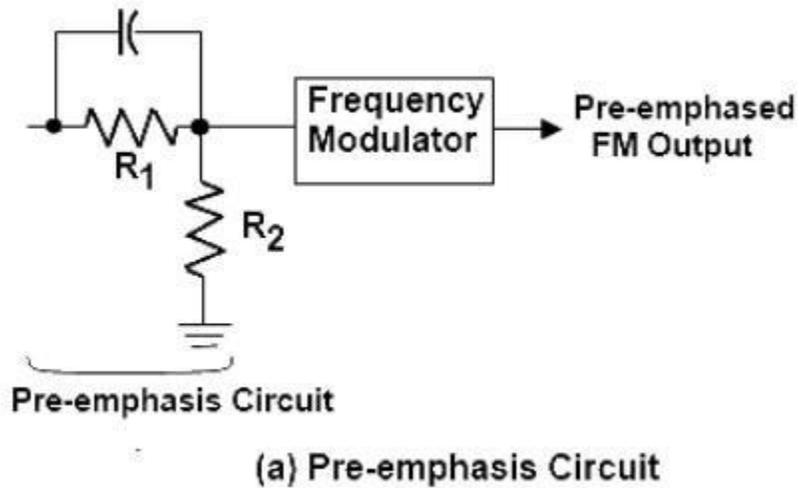

Figure 4.6.1 Pre Emphasis Circuit ,  
Diagram Source Brain Kart

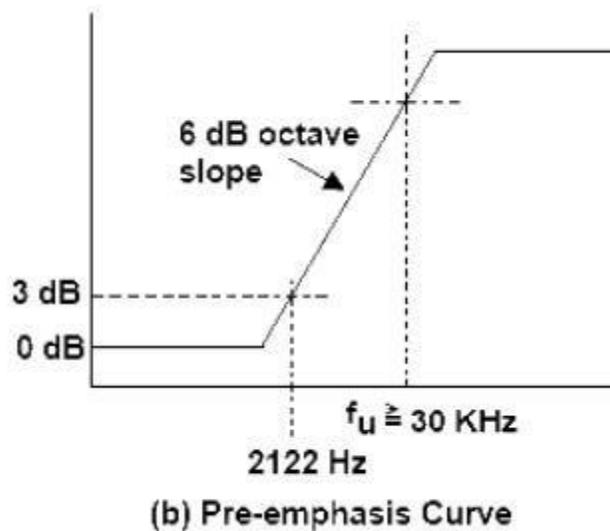
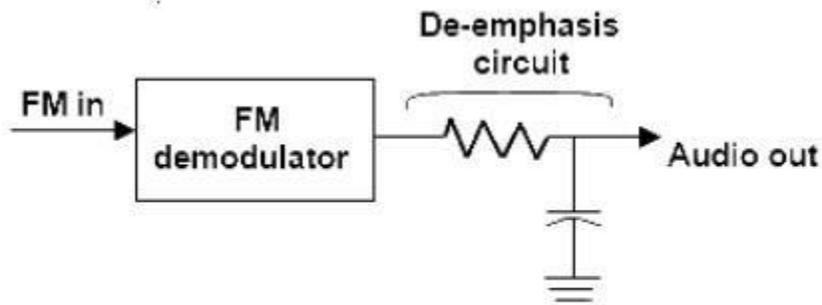

Figure 4.6.2 Pre Emphasis Curve  
Diagram Source Brain Kart

**De-Emphasis Circuit:**

Its higher audio frequencies from 2 to approximately 15 KHz. De-emphasis means attenuating those frequencies by the amount by which they are boosted. However pre-emphasis is done at the transmitter and the de-emphasis is done in the receiver. The purpose is to improve the signal-to-noise ratio for FM reception. A time constant of  $75\mu\text{s}$  is specified in the RC or L/Z network for pre-emphasis and de-emphasis shown in the figure 4.6.3 & 4.6.4



**(c) De-emphasis circuit**

**Figure 4.6.3 De Emphasis Circuit**

*Diagram Source Brain Kart*

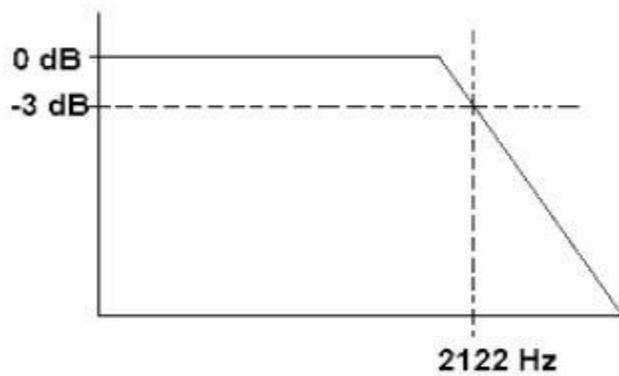

**(d) De-emphasis Curve**

**Figure 4.6.4 De Emphasis Curve**

*Diagram Source Brain Kart*

**Fm Threshold Effect:**

In an FM receiver, the effect produced when the desired-signal gain begins to limit the desired signal, and thus noise limiting (suppression). Note: FM threshold effect occurs at (and above) the point at which the FM signal-to-noise improvement is measured. The output signal to noise ratio of FM receiver is valid only if the carrier to noise ratio is measured at the discriminator input is high compared to unity. It is observed that as the input noise is increased so that the carrier to noise ratio decreased, the FM receiver breaks. At first individual clicks are heard in the receiver output and as the carrier to noise ratio decreases still further, the clicks rapidly merge in to a crackling or sputtering sound. Near the break point eqn 8.50 begins to fail predicting values of output SNR larger than the actual ones. This phenomenon is known as the threshold effect. The threshold effect is defined as the minimum carrier to noise ratio that gives the output SNR not less than the value predicted by the usual signal to noise formula assuming a small noise power. For a qualitative discussion of the FM threshold effect, Consider, when there is no signal present, so that the carrier is unmodulated. Then the composite signal at the frequency discriminator input is

$$x(t) = [A_c + n_I(t)] \cos 2\pi f_c t - n_Q(t) \sin 2\pi f_c t$$

Where  $n_I(t)$  and  $n_Q(t)$  are inphase and quadrature component of the narrow band noise  $n(t)$  with respect to carrier wave  $A_c \cos 2\pi f_c t$ . The phasor diagram of fig 8.17 below shows the phase relations b/n the various components of  $x(t)$  in eqn (1). This effect is shown in fig below, this calculation is based on the following two assumptions:

1. The output signal is taken as the receiver output measured in the absence of noise. The average output signal power is calculated for a sinusoidal modulation that

produces a frequency deviation  $I$  equal to  $1/2$  of the IF filter bandwidth  $B$ , The carrier is thus enabled to swing back and forth across the entire IF band.

2. The average output noise power is calculated when there is no signal present, i.e., the carrier is unmodulated, with no restriction placed on the value of the carrier to noise ratio.

### Assumptions:

- Single-tone modulation, ie:  $m(t) = A_m \cos(2\pi f_m t)$
- The message bandwidth  $W = f_m$ ;
- For the AM system,  $\mu = 1$ ;
- For the FM system,  $\beta = 5$  (which is what is used in commercial FM transmission, with  $\Delta f = 75$  kHz, and  $W = 15$  kHz).

### Noise Characterization - Application & Its Uses:

- Tape Noise reduction.
- PINK Noise or  $1/f$  noise.
- Noise masking and baby sleep

