

## 4.2 BIPOLAR JUNCTION TRANSISTOR

In common emitter configuration, base is the input terminal, collector is the output terminal and emitter is the common terminal for both input and output. That means the base terminal and common emitter terminal are known as input terminals whereas collector terminal and common emitter terminal are known as output terminals.

In common emitter configuration, the emitter terminal is grounded so the common emitter configuration is also known as grounded emitter configuration. Sometimes common emitter configuration is also referred to as CE configuration, common emitter amplifier, or CE amplifier. The common emitter (CE) configuration is the most widely used transistor configuration.

The common emitter (CE) amplifiers are used when large current gain is needed.

The input signal is applied between the base and emitter terminals while the output signal is taken between the collector and emitter terminals. Thus, the emitter terminal of a transistor is common for both input and output and hence it is named as common emitter configuration.

The supply voltage between base and emitter is denoted by  $V_{BE}$  while the supply voltage between collector and emitter is denoted by  $V_{CE}$ .

In common emitter (CE) configuration, input current or base current is denoted by  $I_B$  and output current or collector current is denoted by  $I_C$ .

The common emitter amplifier has medium input and output impedance levels. So, the current gain and voltage gain of the common emitter amplifier is medium. However, the power gain is high.

To fully describe the behavior of a transistor with CE configuration, we need two set of characteristics – input characteristics and output characteristics.

OBSERVE OPTIMIZE OUTSPREAD

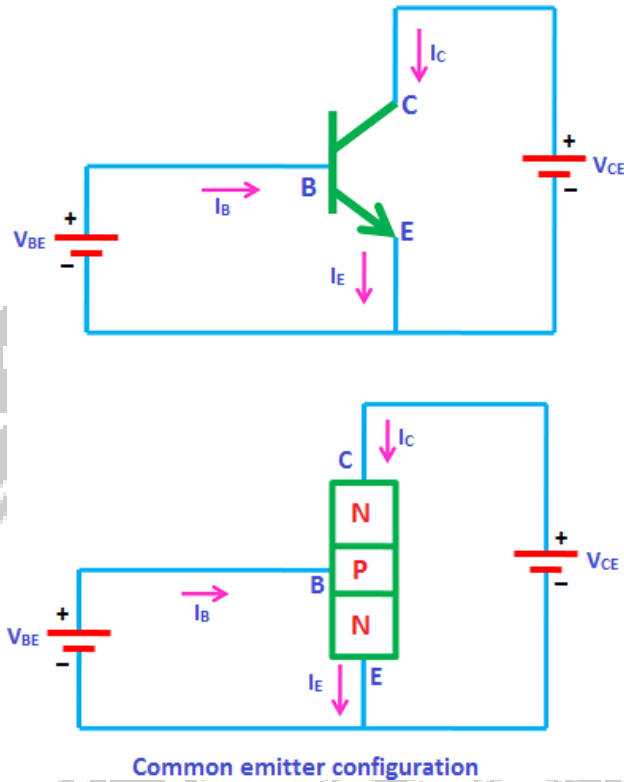

### Input characteristics

The input characteristics describe the relationship between input current or base current ( $I_B$ ) and input voltage or base-emitter voltage ( $V_{BE}$ ).

First, draw a vertical line and a horizontal line. The vertical line represents y-axis and horizontal line represents x-axis. The input current or base current ( $I_B$ ) is taken along y-axis (vertical line) and the input voltage ( $V_{BE}$ ) is taken along x-axis (horizontal line).

To determine the input characteristics, the output voltage  $V_{CE}$  is kept constant at zero volts and the input voltage  $V_{BE}$  is increased from zero volts to different voltage levels. For each voltage level of input voltage ( $V_{BE}$ ), the corresponding input current ( $I_B$ ) is recorded.

OBSERVE OPTIMIZE OUTSPREAD

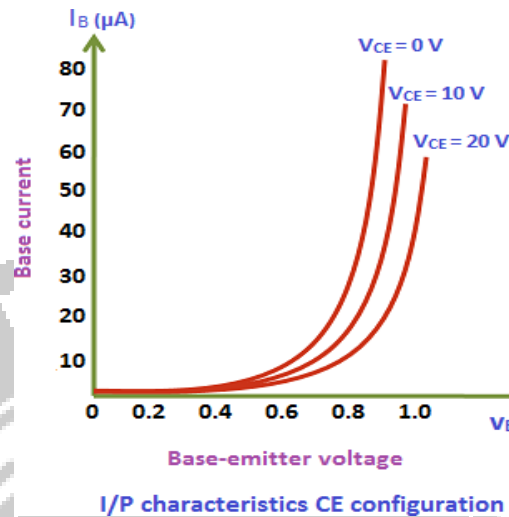

A curve is then drawn between input current  $I_B$  and input voltage  $V_{BE}$  at constant output voltage  $V_{CE}$  (0volts).

Next, the output voltage ( $V_{CE}$ ) is increased from zero volts to certain voltage level (10 volts) and the output voltage ( $V_{CE}$ ) is kept constant at 10 volts. While increasing the output voltage ( $V_{CE}$ ), the input voltage ( $V_{BE}$ ) is kept constant at zero volts. After we kept the output voltage ( $V_{CE}$ ) constant at 10 volts, the input voltage  $V_{BE}$  is increased from zero volts to different voltage levels. For each voltage level of input voltage ( $V_{BE}$ ), the corresponding input current ( $I_B$ ) is recorded.

A curve is then drawn between input current  $I_B$  and input voltage  $V_{BE}$  at constant output voltage  $V_{CE}$  (10volts).

This process is repeated for higher fixed values of output voltage ( $V_{CE}$ ).

When output voltage ( $V_{CE}$ ) is at zero volts and emitter-base junction is forward biased by input voltage ( $V_{BE}$ ), the emitter-base junction acts like a normal p-n junction diode. So the input characteristics of the CE configuration is same as the characteristics of a normal pn junction diode.

The cut in voltage of a silicon transistor is 0.7 volts and germanium transistor is 0.3 volts. In our case, it is a silicon transistor. So, from the above graph, we can see that after 0.7 volts, a small increase in input voltage ( $V_{BE}$ ) will rapidly increases the input current ( $I_B$ ).

In common emitter (CE) configuration, the input current ( $I_B$ ) is very small as compared to the input current ( $I_E$ ) in common base (CB) configuration. The input current in CE configuration is measured in microamperes ( $\mu A$ ) whereas the input current in CB configuration is measured in milliamperes (mA).

In common emitter (CE) configuration, the input current ( $I_B$ ) is produced in the base region which is lightly doped and has small width. So, the base region produces only a small input current ( $I_B$ ). On the other hand, in common base (CB) configuration, the input current ( $I_E$ ) is produced in the emitter region which is heavily doped and has large width. So, the emitter region produces a large input current

(I<sub>E</sub>). Therefore, the input current (I<sub>B</sub>) produced in the common emitter (CE) configuration is small as compared to the common base (CB) configuration.



Due to forward bias, the emitter-base junction acts as a forward biased diode and due to reverse bias, the collector-base junction acts as a reverse biased diode.

Therefore, the width of the depletion region at the emitter-base junction is very small whereas the width of the depletion region at the collector-base junction is very large.

If the output voltage  $V_{CE}$  applied to the collector-base junction is further increased, the depletion region width further increases. The base region is lightly doped as compared to the collector region. So the depletion region penetrates more into the base region and less into the collector region. As a result, the width of the base region decreases which in turn reduces the input current ( $I_B$ ) produced in the base region.

From the above characteristics, we can see that for higher fixed values of output voltage  $V_{CE}$ , the curve shifts to the right side. This is because for higher fixed values of output voltage, the cut in voltage is increased above 0.7 volts. Therefore, to overcome this cut in voltage, more input voltage  $V_{BE}$  is needed than previous case.

**Output characteristics**

The output characteristics describe the relationship between output current ( $I_C$ ) and output voltage ( $V_{CE}$ ).

First, draw a vertical line and a horizontal line. The vertical line represents y-axis and horizontal line represents x-axis. The output current or collector current ( $I_C$ ) is taken along y- axis (vertical line) and the output voltage ( $V_{CE}$ ) is taken along x-axis (horizontal line).

To determine the output characteristics, the input current or base current  $I_B$  is kept constant at  $0 \mu A$  and the output voltage  $V_{CE}$  is increased from zero volts to different voltage levels. output voltage,

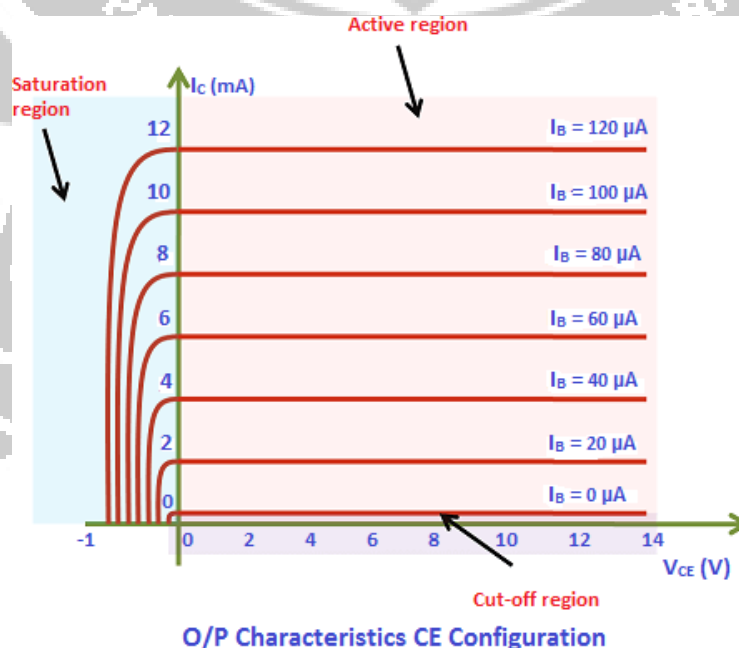

A curve is then drawn between output current  $I_C$  and output voltage  $V_{CE}$  at constant input current  $I_B(0\mu A)$ .

When the base current or input current  $I_B = 0 \mu A$ , the transistor operates in the cut-off region. In this region, both junctions are reverse biased.

Next, the input current ( $I_B$ ) is increased from  $0 \mu A$  to  $20 \mu A$  by adjusting the input voltage ( $V_{BE}$ ). The input current ( $I_B$ ) is kept constant at  $20 \mu A$ .

A curve is then drawn between output current  $I_C$  and output voltage  $V_{CE}$  at constant input current  $I_B(20 \mu A)$ . This region is known as the active region of a transistor. In this region, emitter-base junction is forward biased and the collector-base junction is reverse biased.

This steps are repeated for higher fixed values of input current  $I_B$  (I.e.  $40 \mu A, 60 \mu A, 80 \mu A$  and so on).

When output voltage  $V_{CE}$  is reduced to a small value ( $0.2 V$ ), the collector-base junction becomes forward biased. This is because the output voltage  $V_{CE}$  has less effect on collector-base junction than input voltage  $V_{BE}$ .

As we know that the emitter-base junction is already forward biased. Therefore, when both the junctions are forward biased, the transistor operates in the saturation region. In this region, a small increase in output voltage  $V_{CE}$  will rapidly increases the output current  $I_C$ .

