

## HYDRAULICS AND PNEUMATICS

### Chapter – 2

#### UNIT II HYDRAULIC ACTUATORS AND CONTROL COMPONENTS

Hydraulic motors – Control Components : Hydraulic control valves configuration, Construction and Operation.

#### **HYDRAULIC MOTORS:**

A hydraulic motor converts fluid power into mechanical power in the form of rotational motion. Motors perform the opposite function of the pump, which converts mechanical power from an electric motor or engine into fluid power. Motors take pump flow and pressure as their input and output rotational motion and torque. Motor displacement is the volume. Pump displacement is the volume of the pump outputs per revolution of the pump shaft, a similar concept. Like pump motors can be fixed or variable displacement. Increasing the displacement of a motor decreases its speed because it requires more fluid to turn it each revolution. Increasing displacement increases torque output because more area within the motor is subjected to pressure. Decreasing motor displacement increases speed and decreases torque.

Hydraulic motors are most commonly gear, vane or piston type. All have a construction similar to the hydraulic pump of the same type. They also have similar properties. Gear motors are the least efficient, most dirt tolerant and have the lowest pressure ratings of the three. Piston motors are the most efficient, least dirt tolerant and have the highest pressure ratings. Vane and piston motors can be fixed or variable displacement like vane and piston pumps. Gear motors like gear pump are not available with variable displacement.

#### **GEAR MOTOR:**

The operation of gear motor is shown in the figure. One of the gears

is keyed to an output shaft, while the other is simply an idler gear. Pump flow and pressure are sent to the inlet port of the motor. The pressure is then applied to the gear teeth, causing the gears and the output shaft to rotate. The pressure builds until enough torque is generated to rotate the output shaft against the load. Most gear motors are bi-directional the direction of rotation can be reversed by simply reversing the direction of flow.

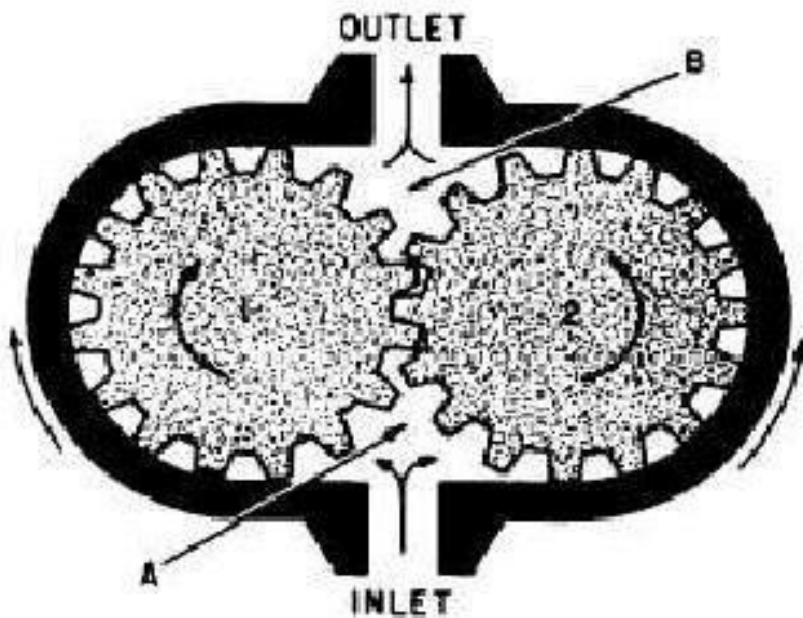

### VANE MOTORS:

In this type of motors the pump flow and pressure are applied to the vanes and the output shaft is rotated. The figure shows the balanced vane type motor. Recall from the discussion on vane pumps that balanced means that pressure is applied on both sides of the shaft resulting in no net force on the bearings.

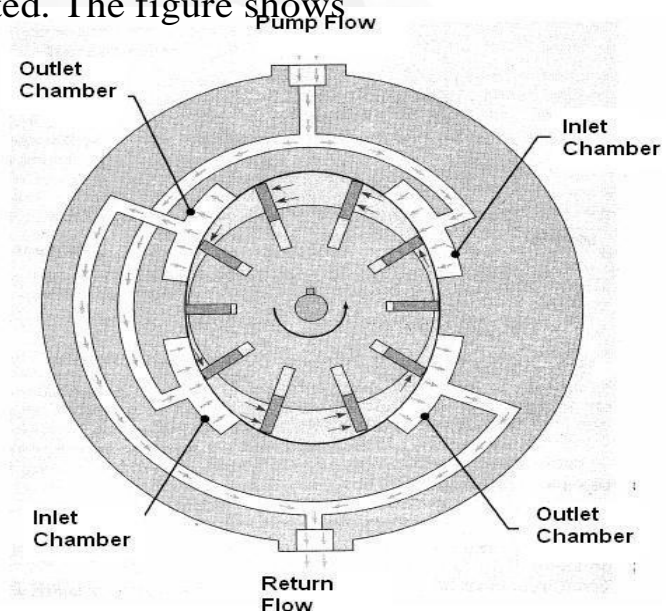

This increases the maximum operating pressure and drive speed at which the motor can operate. The vanes extend and retract twice per revolution of the rotor, which necessitates the use of two inlet and two outlet chambers. These chambers are combined into one common inlet and one common outlet within the motor housing. Most of the vane motors are bidirectional.

### PISTON TYPE MOTORS:

Piston motor develops an output torque at its shaft by allowing hydraulic pressure to act on pistons. Piston designs may be either axial piston type or radial piston type.

#### AXIAL PISTON MOTORS:

**Swash plate or bent axis type:** It consists of a port plate, cylinder barrel, pistons, shoe plate, swash plate and a shaft. The arrangement is similar to a swash plate type pump. When fluid pressure acts on a piston, a force is developed which pushes the piston out and causes the piston shoe to slide across the swash plate surface. As the piston shoe slides, it develops a torque attached to the barrel.

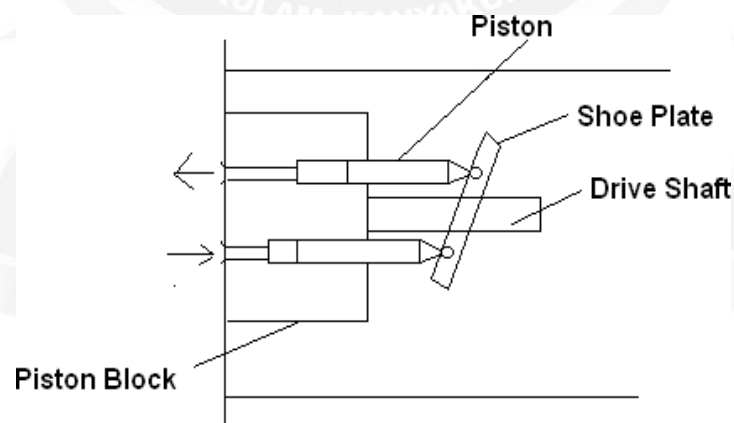

Swash Plate Type

The amount of torque depends on the angle of slide caused by the swash plate and the pressure in the system. Since the swash plate angle controls the stroke in pistons of an axial piston motor, changing the angle will alter

the stroke and motor displacement. The operating principle of an **bent axis motor** is similar to swash plate type. The angle of the cylinder block assembly with respect to drive shaft determines the stroke or motor displacement. Both these motors are used in high speed application only.

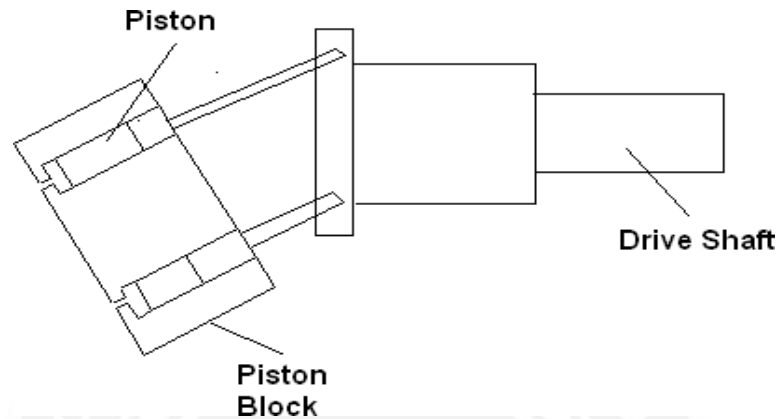

Bent Axis Type

**SEMI ROTARY ACTUATORS:**

These are used to convert fluid pressure energy into torque which turns through an angle limited by the design of the actuator. With the majority of designs, the angle of rotation is within 360 degrees although it is possible to considerably exceed this when using piston operated actuators.

**VANE TYPE ACTUATORS:**

Vane type semi rotary actuator consists of one or two vanes connected to an output shaft which rotates when hydraulic pressure is

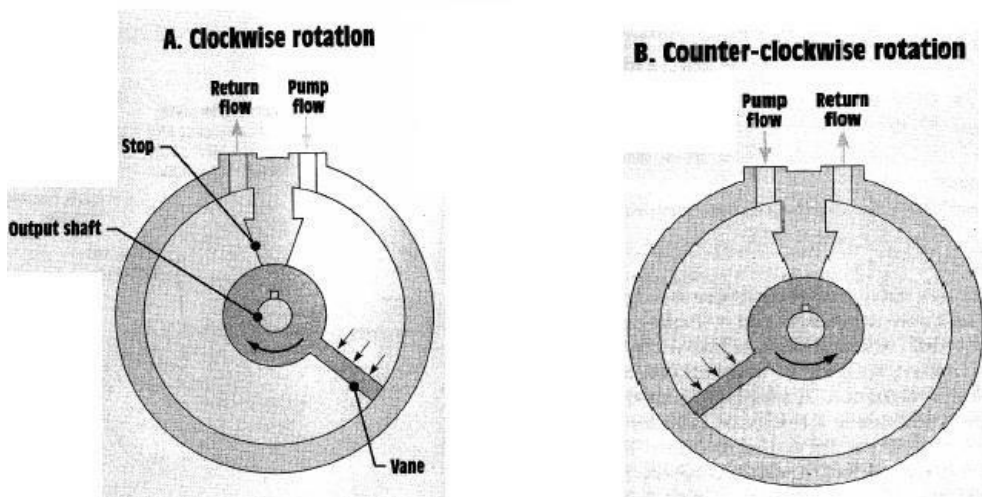

applied to one side of the vanes. A single vane is limited to 280° rotation

and a double vane unit to approximately 100°. Power in a two vane design is doubled.

There will always be some internal fluid leakage across the vanes and these increases with the operating pressure as the viscosity of the working fluid decreases. This causes problems where a smooth speed control of the rotary motion is required. So, for the applications of vane type actuators, the manufacturer's recommendations regarding the operating pressure and type of fluid must be followed.

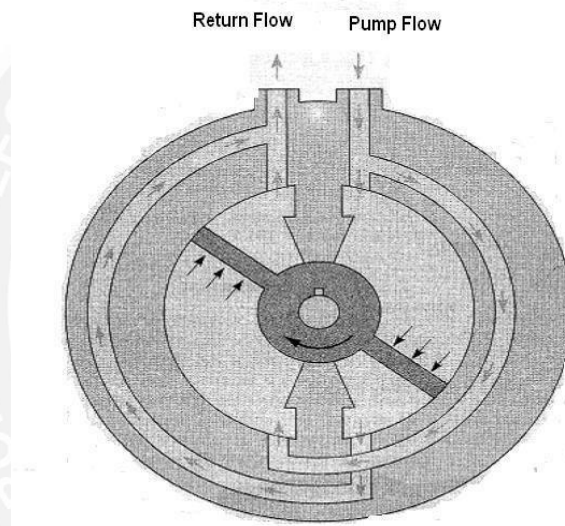

Double Vane Semi Rotary Actuators

The maximum torque obtainable from the currently available single vane unit is approximately  $40 \times 10^3$  Nm and for double vane unit is  $80 \times 10^3$  Nm.

#### **PISTON TYPE SEMI ROTARY ACTUATORS:**

##### **RACK AND PINION SEMI ROTARY ACTUATOR:**

In this design, the cylinder drives a pinion gear and the rack is an integral part of the piston rod. The angle of rotation depends upon the stroke of the cylinder, rack and the pitch circle diameter of the pinion. The start and finish of the stroke is adjusted by means of an internal stop. The output torque available from the rack and pinion type is in an excess of  $80 \times 10^3$  Nm at a pressure of 210 bar.

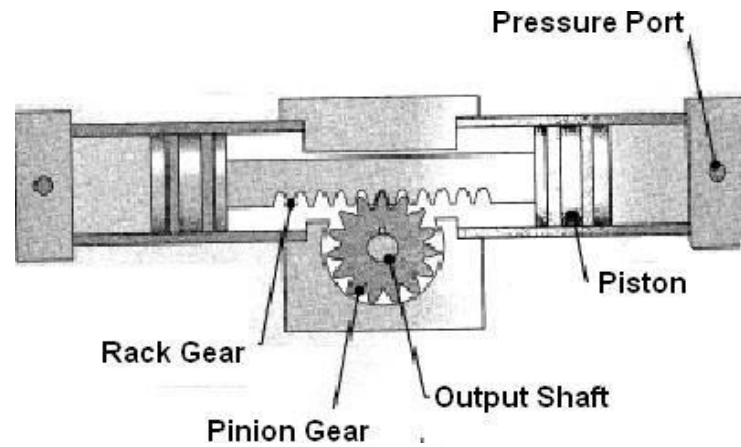

**LEVER ARM SEMI ROTARY ACTUATOR:**

A double

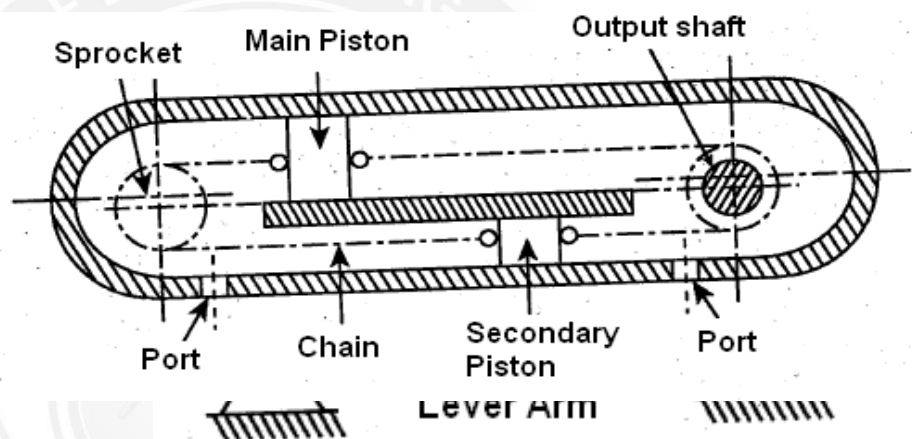

acting cylinder can be made to generate rotary motion by using a lever arm. The angle of rotation

will be less than 180°. The output is the product of {Piston thrust x Sin φ x length of lever}.

**CHAIN AND SPROCKET SEMI ROTARY ACTUATOR:**

In this design an endless chain and sprocket is used and it is suitable for multi revolution applications. The chain is anchored to two pistons, one large and the other small, which when in their respective bores, separate the halves of the unit. The large cylinder is the power cylinder and the

small cylinder is the chain return or seal cylinder.

The idler is automatically a tensioned one, so a constant tension is maintained. Pressure is applied to one port of the actuator. The larger piston moves away from the port due to the differential area of the two pistons. Movement of the larger piston pulls the chain, causing the sprocket and output shaft to rotate.

### HELICAL SCREW SEMI ROTARY ACTUATOR:

This type consists of a cylinder in which the piston is prevented from rotating by guide rods. The piston rod and the piston contain a helical groove and they mate together analogous to a screw and a nut. As the piston is driven along the barrel, it causes the rod to rotate.

Because of the difficulty in providing a hydraulic seal between the piston and rod, this design is limited to low pressure applications. The self locking helix angle of the piston and rod eliminate the possibility of external torque causing any rotary movement of the piston rod.

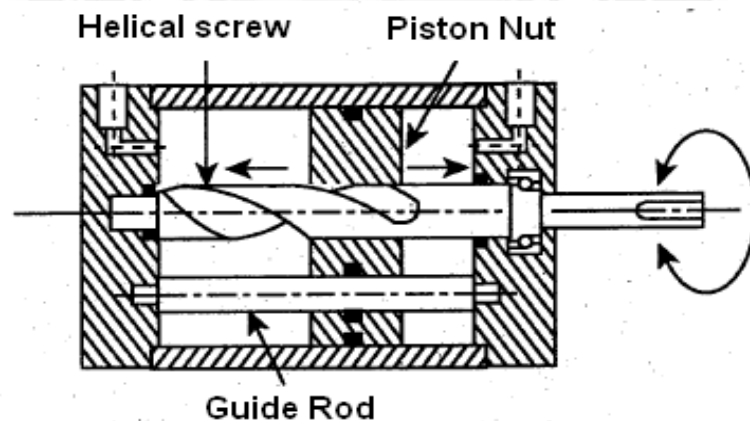

### CONTROL VALVES

In a hydraulic system, the hydraulic energy available from a pump is converted into motion and force by means of an actuator. The control of these mechanical outputs (motion and force) is one of the most important functions in a hydraulic system. The proper selection of control selection ensures the desired output and safe function of the system. In order to control the hydraulic outputs, different types of control valves are required. It is important to know various types of control valves and their functions. This

not only helps to design a proper hydraulic system but also helps to discover the innovative ways to improve the existing systems. In this lecture and next few lectures, various types of valves will be discussed.

There are basically three types of valves employed in hydraulic systems:

1. Directional control valves
2. Flow control valves
3. Pressure control valves

## FLOW CONTROL VALVES

In practice, the speed of actuator is very important in terms of the desired output and needs to be controlled. The speed of actuator can be controlled by regulating the fluid flow. A flow control valve can regulate the flow or pressure of the fluid. The fluid flow is controlled by varying area of the valve opening through which fluid passes. The fluid flow can be decreased by reducing the area of the valve opening and it can be increased by increasing the area of the valve opening. A very common example to the fluid flow control valve is the household tap. The pressure adjustment screw varies the fluid flow area in the pipe to control the discharge rate.

The pressure drop across the valve may keep on fluctuating. In general, the hydraulic systems have a pressure compensating pump. The inlet pressure remains almost constant but the outlet pressure keeps on fluctuating depending on the external load. It creates fluctuating pressure drop. Thus, the ordinary flow control valve will not be able to maintain a constant fluid flow. A pressure compensated flow control valve maintains the constant flow throughout the movement of a spool, which shifts its position depending on the pressure. Flow control valves can also be affected by temperature changes. It is because the viscosity of the fluid changes with temperature. Therefore, the advanced flow control valves often have

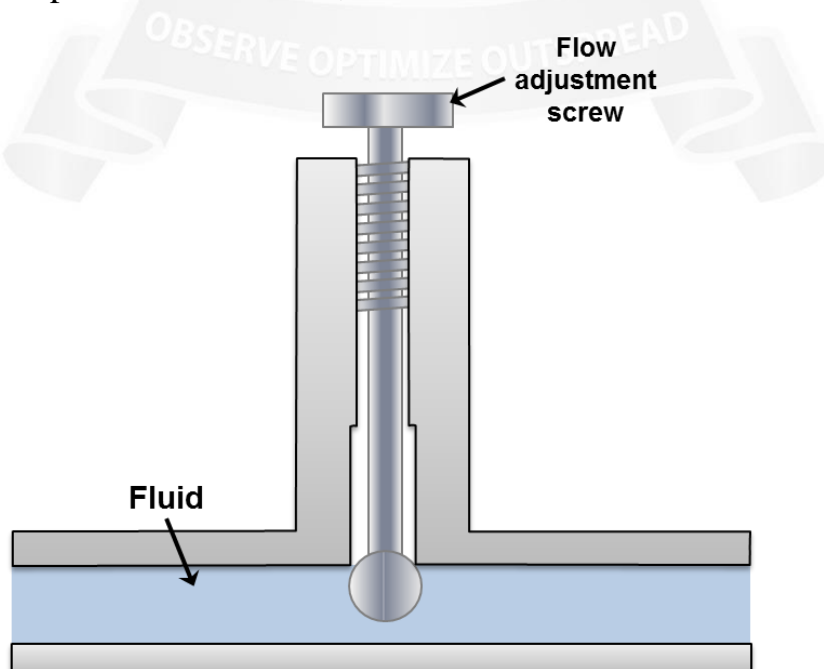



the temperature compensation. The temperature compensation is achieved by the thermal expansion of a rod, which compensates for the increased coefficient of discharge due to decreasing viscosity with temperature.

## PLUG VALVE

The plug valve is quite commonly used valve. It is also termed as glove valve. Schematic of plug or glove valve is shown in Figure 5.5.12. This valve has a plug which can be adjusted in vertical direction by setting flow adjustment screw. The adjustment of plug alters the orifice size between plug and valve seat. Thus the adjustment of plug controls the fluid flow in the pipeline. The characteristics of these valves can be accurately predetermined by machining the taper of the plug. The typical example of plug valve is stopcock that is used in laboratory glassware. The valve body is made of glass or teflon. The plug can be made of plastic or glass. Special glass stopcocks are made for vacuum applications. Stopcock grease is used in high vacuum applications to make the stopcock air-tight.

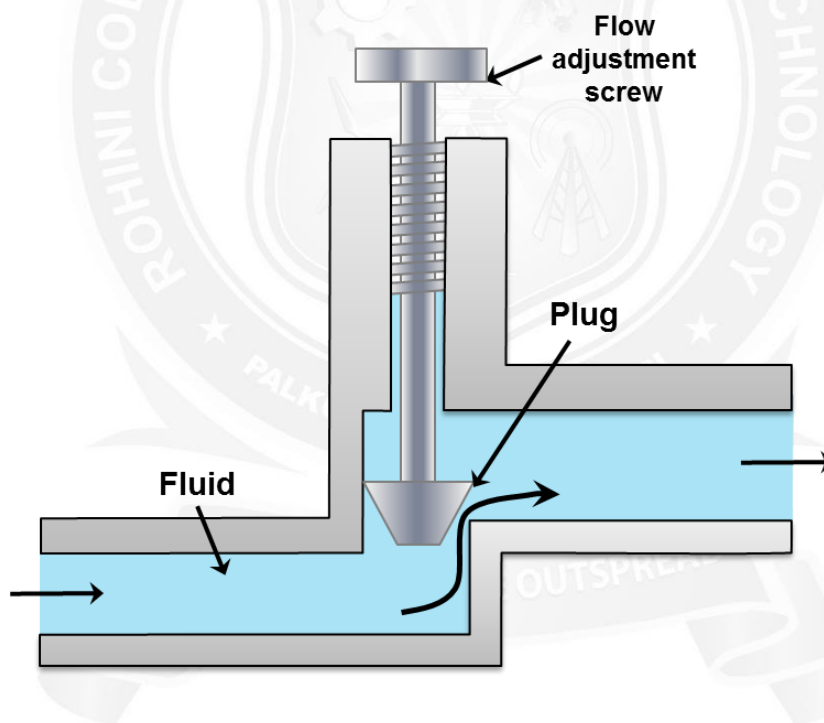

## BUTTERFLY VALVE

A butterfly valve is shown in Figure. It consists of a disc which can rotate inside the pipe. The angle of disc determines the restriction. Butterfly valve can

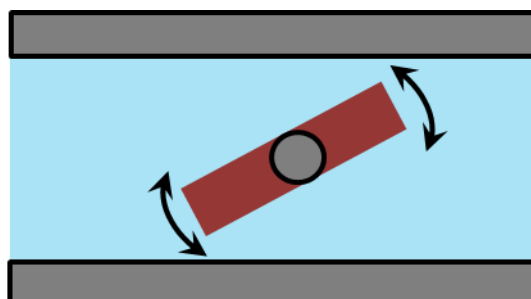

be made to any size and is widely used to control the flow of gas. These valves have many types which have for different pressure ranges and applications. The resilient butterfly valve uses the flexibility of rubber and has the lowest pressure rating. The high performance butterfly valves have a slight offset in the way the disc is positioned. It increases its sealing ability and decreases the wear. For high-pressure systems, the triple offset butterfly valve is suitable which makes use of a metal seat and is therefore able to withstand high pressure. It has higher risk of leakage on the shut-off position and suffer from the dynamic torque effect. Butterfly valves are favored because of their lower cost and lighter weight. The disc is always present in the flow therefore a pressure drop is induced regardless of the valve position.

## BALL VALVE

This type of flow control valve uses a ball rotated inside a machined seat. It has very less leakage in its shut-off condition. These valves are durable and usually work perfectly for many years. They are excellent choice for shutoff applications. They do not offer fine control which may be necessary in throttling applications. These valves are widely used in industries because of their versatility, high supporting pressures (up to 1000 bar) and temperatures (up to 250°C). They are easy to repair and operate.

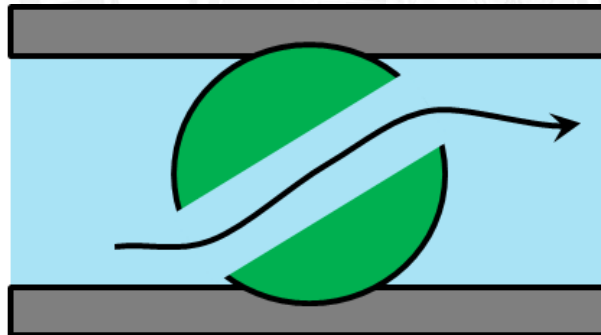

## BALANCED VALVE

It comprises of two plugs and two seats. The opposite flow gives little dynamic reaction onto the actuator shaft. It results in the negligible dynamic torque effect. However, the leakage is more in these kind of valves because the manufacturing tolerance can cause one plug to seat before the other. The pressure-balanced valves are used in the houses. They provide water at nearly constant temperature to a shower or bathtub despite of pressure fluctuations in either the hot or cold supply lines.

