

5.4 CONSTRUCTION AND WORKING PRINCIPLE OF A MOVING IRON INSTRUMENT:

Classification of Moving Iron Instruments

Moving iron instruments are of two types

- (i) Attraction type. (ii) Repulsion type.

Attraction Type

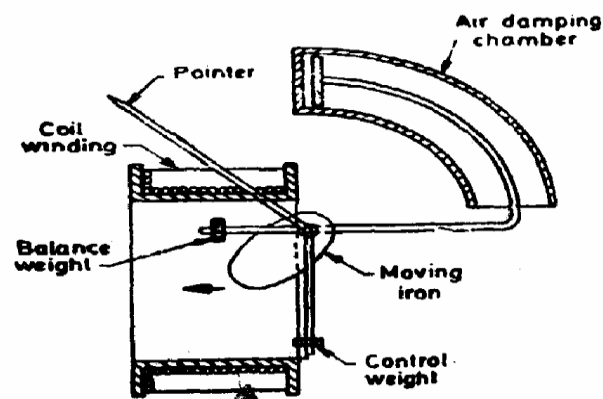

- The coil is flat and has a narrow slot like opening.
- The moving iron is a flat disc or a sector eccentrically mounted.
- When the current flows through the coil, a magnetic field is produced and the moving iron moves from the weaker field outside the coil to the stronger field inside it or in other words the moving iron is attracted in.
- The controlling torque is providing by springs but gravity control can be used for panel type of instruments which are vertically mounted.
- Damping is provided by air friction with the help of a light aluminium piston (attached to the moving system) which move in a fixed chamber closed at one end as shown in Fig. or with the

help of a vane (attached to the moving system) which moves in a fixed sector shaped chamber as shown.

Repulsion Type

In the repulsion type, there are two vanes inside the coil one fixed and other movable. These are similarly magnetized when the current flows through the coil and there is a force of repulsion between the two vanes resulting in the movement of the moving vane. Two different designs are in common use.

(I) Radial Vane Type

In this type, the vanes are radial strips of iron.

The strips are placed within the coil as shown in Fig.

The fixed vane is attached to the coil and the movable one to the spindle of the instrument.

(a) Radial vane type (b) Co-axial vane type

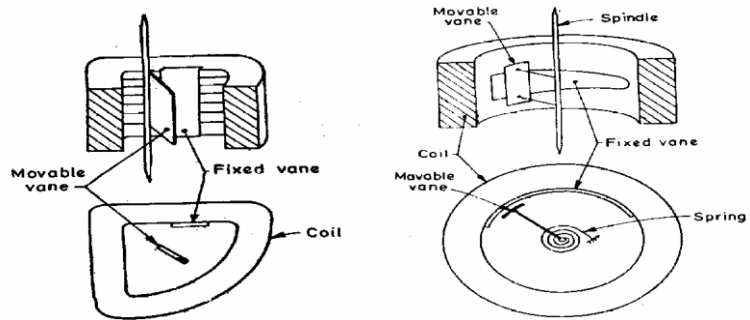

(ii) Co-axial Vane Type

- In this type of instrument, the fixed and moving vanes are sections of co axial cylinders as shown in Fig.
- The controlling torque is provided by springs. Gravity control can also be used in vertically mounted instruments.
- The damping torque is produced by air friction as in attraction type instruments.
- The operating magnetic field in moving iron instruments is very weak and therefore eddy current damping is not used in them as introduction of a permanent magnet required for eddy current damping would destroy the operating magnetic

field.

- It is clear that whatever may be the direction of the current in the coil of the instrument, the iron vanes are so magnetized that there is always a force of attraction in the attraction type and repulsion in the repulsion type of instruments.
- Thus moving iron instruments are unpolarised instruments i.e., they are independent of the direction in which the current passes.
- Therefore, these instruments can be used on both ac. and d.c.

Torque Equation of Moving Iron Instrument:

An expression for the torque moving iron instrument may be derived by considering the energy relations when there is a small increment in current supplied to the instrument. When this happens there will be a small deflection $d\phi$ a mechanical work will be done. Let T_d be the deflecting torque.

Mechanical work done = $T_d \cdot d\phi$

Alongside there will be a change in the energy stored in the magnetic field owing to change in inductance. Suppose the initial current is I , the instrument inductance L and the deflection ϕ . If the current is increased by dI then the deflection changes by $d\phi$ and the inductance by dL . In order to affect a small increment the current there must be an increase in the applied voltage given by Hence

OBSERVE OPTIMIZE OUTSPREAD

$$e = \frac{d}{dt} (LI) = I \frac{dL}{dt} + L \frac{dI}{dt}$$

The electrical energy supplied $eI dt = I^2 dL + IL dI$

The stored energy changes from $= \frac{1}{2} I^2 L$ to $\frac{1}{2} (I + dI)^2 (L + dL)$.

Hence the change in stored energy $\frac{1}{2} (I^2 + 2IdI + dI^2) (L + dL) - \frac{1}{2} I^2 L$.

Neglecting second and higher order terms in small quantities this becomes $IL dI + \frac{1}{2} I^2 dL$

From the principle of the conservation of energy,

Electrical energy supplied = increase in stored energy + mechanical work done

$$I^2 dL + IL dI = IL dI = \frac{1}{2} I^2 dL + T_d d\theta$$

Thus

$$T_d d\theta = \frac{1}{2} I^2 dL$$

or Deflecting torque

$$T_d = \frac{1}{2} I^2 \frac{dL}{d\theta}$$

T is in newton-metre, I in ampere, L in henry, and θ in radian.

The moving system is provided with control springs and it turns the deflecting torque T_d is balanced by the controlling torque $T_c = K\theta$

where K = control spring constant ; Nm/rad, θ = deflection ; rad.

At equilibrium (or final steady) position, $T_c = T_d$ or $K\theta = \frac{1}{2} I^2 \frac{dL}{d\theta}$

\therefore Deflection

$$\theta = \frac{1}{2} \frac{I^2}{K} \frac{dL}{d\theta}$$

Hence the deflection is proportional to square of the rms value of the operating current. The deflecting torque is, therefore, unidirectional (acts in the same direction) whatever may be the polarity of the current.