

2.1 Analog and Digital Data Conversion

The natural state of audio and video signals is analog. When digital technology was not yet around, they are recorded or played back in analog devices like vinyl discs and cassette tapes. The storage capacity of these devices is limited and doing multiple runs of re-recording and editing produced poor signal quality. Developments in digital technology like the CD, DVD, Blu-ray, flash devices and other memory devices addressed these problems.

For these devices to be used, the analog signals are first converted to digital signals using analog to digital conversion (ADC). For the recorded audio and video signals to be heard and viewed again, the reverse process of digital to analog conversion (DAC) is used. ADC and DAC are also used in interfacing digital circuits to analog systems. Typical applications are control and monitoring of temperature, water level, pressure and other real-world data.

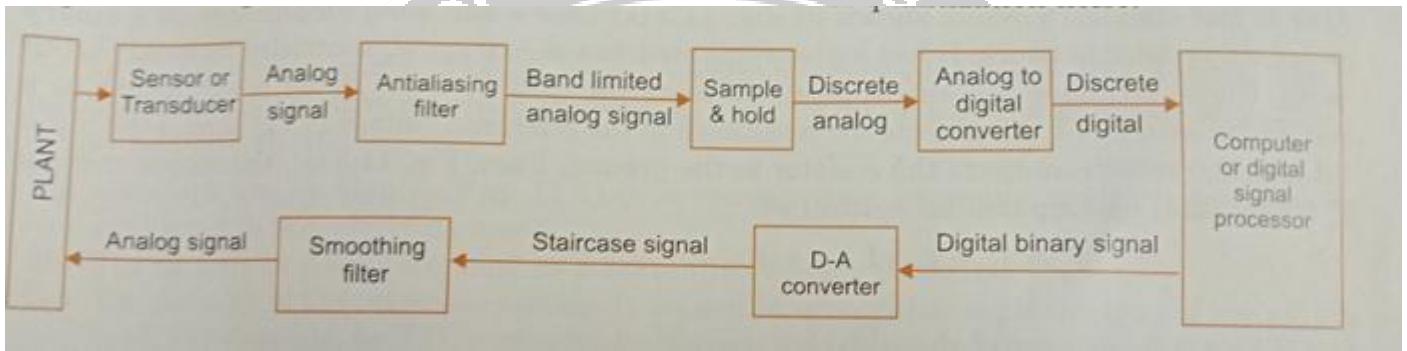

Fig 1 Circuit showing application of A/D and D/A converter(source: D.Roy Choudhry, Shail Jain, —Linear Integrated Circuits, New Age International Pvt. Ltd., 2018, Fifth Edition.)

Fig 1. ,highlights a typical application within which A/D and D/A conversion is used.The analog signal obtained from the transducer is band limited by antialiasing filter.The signal is then sampled at a frequency rate more than twice the maximum frequency of the band limited signal.The sampled signal has to be held constant while conversion is taking place in A/D converter.This requires that ADC should be preceded by a sample and hold circuit.The ADC output is a sequence in binary digit.The micro-computer or digital signal processor performs the numerical calculations of the desired control algorithm.The D/A converter is to convert digital signal into analog and hence the function of DAC is exactly opposite to that of ADC.The D/A converter is usually operated at the same frequency as the ADC.The output of a D/A converter is commonly a staircase.This staircase-like digital output is passed through a smoothing filter to reduce the effect of quantization noise.

The scheme given in figure is used either in full or in part in applications such as digital audio recording and playback, computer, music and video synthesis, pulse code modulation transmission, data acquisition, digital multimeter, direct digital control, digital signal processing, microprocessor based instrumentation.

Both ADC and DAC are also known as data converters and are available in IC form.It may be mentioned here that for slowly varying signal, sometimes sample and hold circuit may be avoided without considerable error.

Basic D/A Conversion Techniques

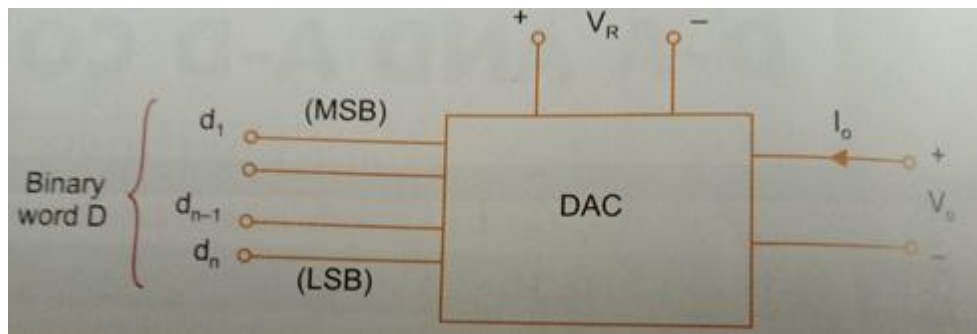

Fig 2.Schematic of a DAC(source: D.Roy Choudhry, Shail Jain, —Linear Integrated Circuits, New Age International Pvt. Ltd., 2018, Fifth Edition.)

Fig 2 shown above is the schematic of a DAC.The i/p is a n-bit binary word D.& is combined with a reference voltage V_R . To give an analog o/p signal.The o/p of a DAC can be either a voltage or current.For a voltage o/p DAC ,the D/A converter is mathematically described as

$$V_o = KV_{FS}(d_12^{-1} + d_22^{-2} + \dots + d_n2^{-n})$$

where, V_o = output voltage

V_{FS} = full scale output voltage

K = scaling factor usually adjusted to unity

$d_1, d_2, \dots, d_n = n$ –

bit binary fractional word with the decimal point located at the left

d_1 = MSB with a weight of $\frac{V_{FS}}{2}$

d_n = LSB with a weight of $\frac{V_{FS}}{2^n}$

Types of DAC

- Weighted Resistor DAC
- R-2R Ladder DAC
- Voltage mode R-2R Ladder D/A converter
- Inverted or Current mode R-2R Ladder D/A converter