



ROHINI

COLLEGE OF ENGINEERING AND TECHNOLOGY

Approved by AICTE and affiliated to Anna University Chennai (An ISO Certified Institution)

Accredited by NAAC with A+ Grade

DEPARTMENT OF BIOMEDICAL ENGINEERING

BM3491 Biomedical Instrumentation

UNIT-III BIOAMPLIFIERS

3.3 Isolation Amplifiers

3.3.1 Isolation amplifiers:

Some hospital patients are extraordinarily susceptible to electrical shock hazards. It is believed that 60-Hz ac currents small enough to be deemed harmless ordinarily may be lethal to a patient under certain circumstances.

An isolation amplifier can be defined as, an amplifier which doesn't have any conductive contact among input as well as output sections. Consequently, this amplifier gives ohmic isolation among the i/p & o/p terminals of the amplifier. This isolation must have less leakage as well as a high amount of dielectric breakdown voltage. The typical resistor and capacitor values of amplifier among the input & output terminals are resistor should have 10 Tera Ohms and capacitor should have 10 picofarads.

An isolation amplifier or a unity gain amplifier provides isolation from one fraction of the circuit to another fraction. So, the power cannot be drawn, used and wasted within the circuit. The main function of this amplifier is to increase the signal. The same input signal of the op-amp is passed out exactly from the op-amp as an output signal. These amplifiers are used to give an electrical safety barrier as well as isolation. These amplifiers protect the patients from the outflow of current. They crack electrical signal's ohmic continuity among input & output and isolated power supply can be provided for both the input and output. So, the low-level signals can be amplified.

These amplifiers are frequently used when there is extremely huge common-mode voltage disparity among input & output side. In this amplifier, the ohmic circuitry is not there from input ground to output ground.

Isolation Amplifier Design Methods

There are three kinds of design methods are used in isolation amplifiers which include the following.

- Transformer Isolation
- Optical Isolation
- Capacitive Isolation

1). Transformer Isolation

This type of isolation uses two signals like PWM or frequency modulated. Internally, this amplifier includes 20 KHz oscillator, rectifier, filter, and transformer to give supply to every isolated stage.

- The rectifier is used as an input to the main op-amp.
- Transformer links the supply.
- The oscillator is used as an input to the secondary op-amp.
- An LPF is used for removing the components of other frequency.

The advantages of transformer isolation mainly include high CMRR, linearity, and accuracy.

The applications of transformer isolation mainly include medical, nuclear and industrial.

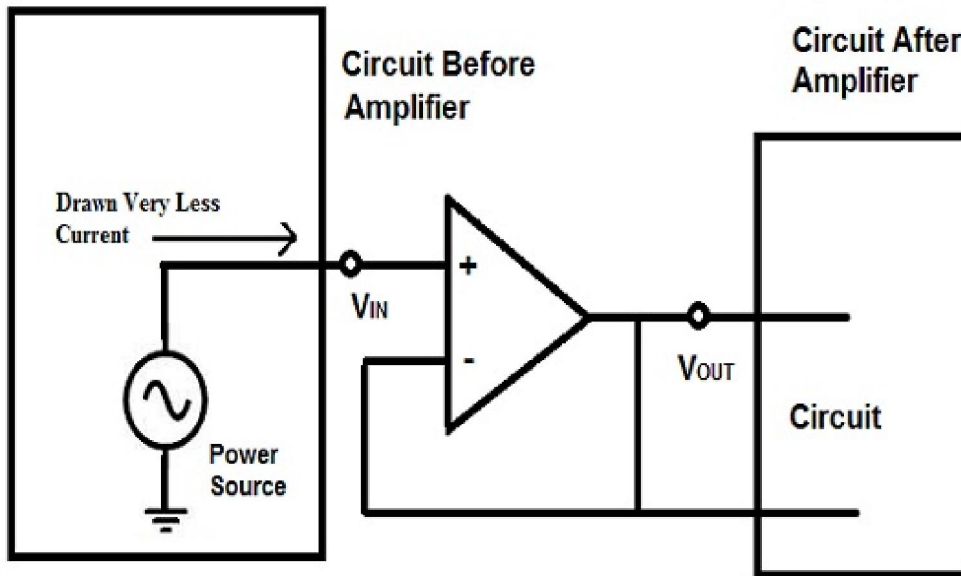

Therefore, an op-amp does not draw a significant quantity of current from the power source. So, in practice, there is no current will be drawn as well as transferred from one portion to another portion of the circuit. Therefore, this amplifier works as an isolation device.

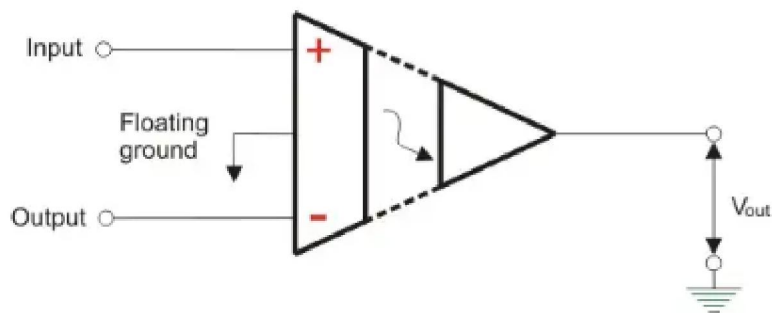

Symbol of Isolation Amplifier

When the input impedance of an op-amp is low then it draws a vast amount of current. Ohms law states that, if load impedance has less resistance, then it draws huge current by the source of power so that high disturbances can be caused, and this is

quite opposite to isolation. Here, isolation amplifier works like a buffer and they do not strengthen signals although provide to isolate divisions of circuits.

Isolation Amplifier Applications

- i. These amplifiers are normally used in applications like signal conditioning. This may utilize different bipolar, CMOS, & complementary bipolar amplifiers which include chopper, isolation, instrumentation amplifiers.
- ii. As several devices work by using low power sources otherwise batteries. Selecting an isolation amplifier for different applications mainly depends on the supply voltage characteristics of an amplifier.
- iii. Thus, this is all about Isolation amplifiers which can be used to isolate the signals like input & output electrically with inductive couplings. These amplifiers protect the electrical and electronic components from over voltages in different applications using numerous channels.

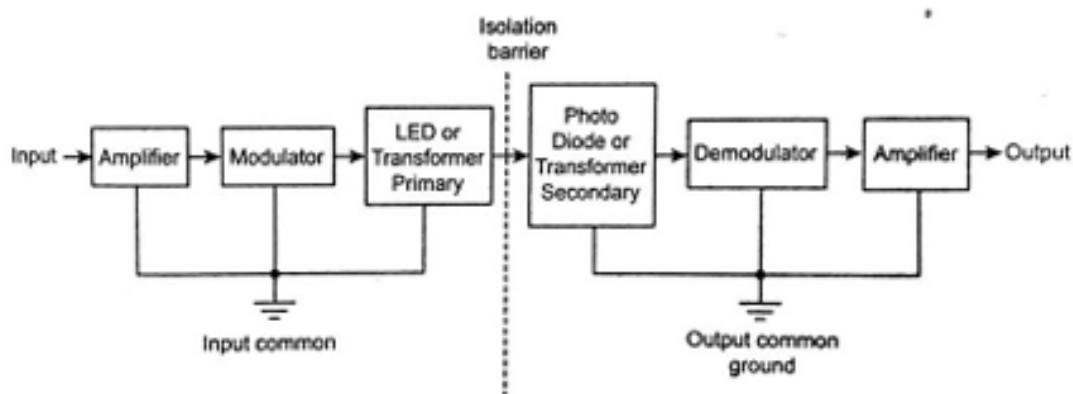

Block diagram of Isolation Amplifier

The electrical signals are obtained with electrodes. The signals received goes to the amplifier block, where signals amplification occurs. After amplification, the signal enters the modulation block. When either it goes to the isolation barrier, optical cable or transformer can be used. If in case of optical cable, modulator output travels to LED. The LED converts electrical signals into light energy. If the transformer acts as isolation barrier, modulator output connects the primary winding of the transformer. Energy from primary transformers to the secondary winding based on the mutual

induction principle. At the next stage, secondary output enters the demodulation block. Finally, the amplified demodulated signal is obtained.

ECG Isolation Amplifier: (Transformer Coupled)

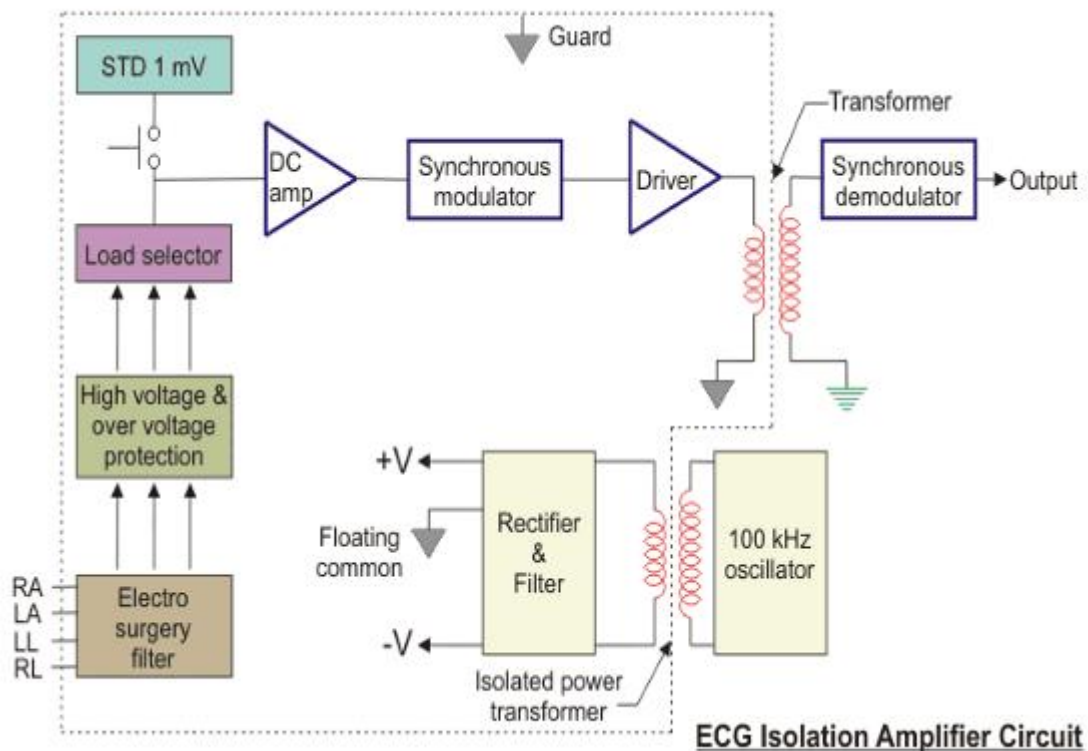

- i. The signals from the different leads are given to the low pass filter having a cut off frequency about 10kHz. This filtering reduces the interference caused by electro surgery and radio frequency emission.
- ii. The filter circuit is followed by high voltage and over voltage protection circuits so that the amplifier can withstand large voltages during defibrillation. Now the signals are fed into the lead selector switch which is used to device the required lead configuration and the output of lead selector is given to a dc amplifier.
- iii. The dc amplifier can also receive a standard dc voltage of 1mV through a push button for calibration purposes. The primary of an isolated low capacitance power transformer is connected with the 100KHz oscillator.

- iv. The secondary of that transformer along with the rectifier and filter circuits is used to obtain isolated power supply of $\pm 6V$ for operating the devices in the isolated portion of the circuit. The synchronous modulator modulates the ECG signal from the dc amplifier, at 100kHz in a linear manner. Another transformer is used to deliver the output from the driver of the modulator to the synchronous demodulator.
- v. The figure shows a block diagram of an isolation preamplifier used in modern electrocardiographs. Difference signals obtained from the right arm (RA), left arm (LA) and right leg (RL) is given to a low pass filter. Filtering is required on the input leads to reduce interference caused by electrosurgery and radio frequency emissions and sometimes from the 50kHz current used for respiration detection.
- vi. The filter usually has a cut off frequency higher than 10kHz. A multistage filter is needed to achieve a suitable reduction in high frequency signal. The filter circuit is followed by high voltage and over voltage protection circuits so that the amplifier can withstand large voltages during defibrillation.
- vii. However, the price of this protection is a relatively high amplifier noise level arising from the high resistance in each level. The oscillator frequency of 100kHz is chosen as a compromise so that reasonable size transformers could be used and that the switching time is not too fast, so that inexpensive transistors and logic circuitry can be utilized.
- viii. A square wave is utilized to minimize the power requirements of the driven transistors. Isolation of the patient preamplifier can also be obtained using an optical isolated.

2) Optical Isolation amplifier:

In this isolation, the I signal can be changed from biological to light signal with LED for further process. In this, the patient circuit is input circuit whereas the output circuit can be formed by a phototransistor. These circuits are operated with a battery. The i/p circuit changes the signal into the light as well as the o/p circuit changes the light back to the signal.

The advantages of optical isolation mainly include;

- By using this we can obtain amplitude and original frequency.
- It connects optically without the need of modulator otherwise demodulator.
- It improves the safety of the patient.

The applications of transformer isolation mainly include process control in industries, data acquisition, measurements of biomedical, monitoring of the patient, interface element, test equipment, controlling of SCR, etc.

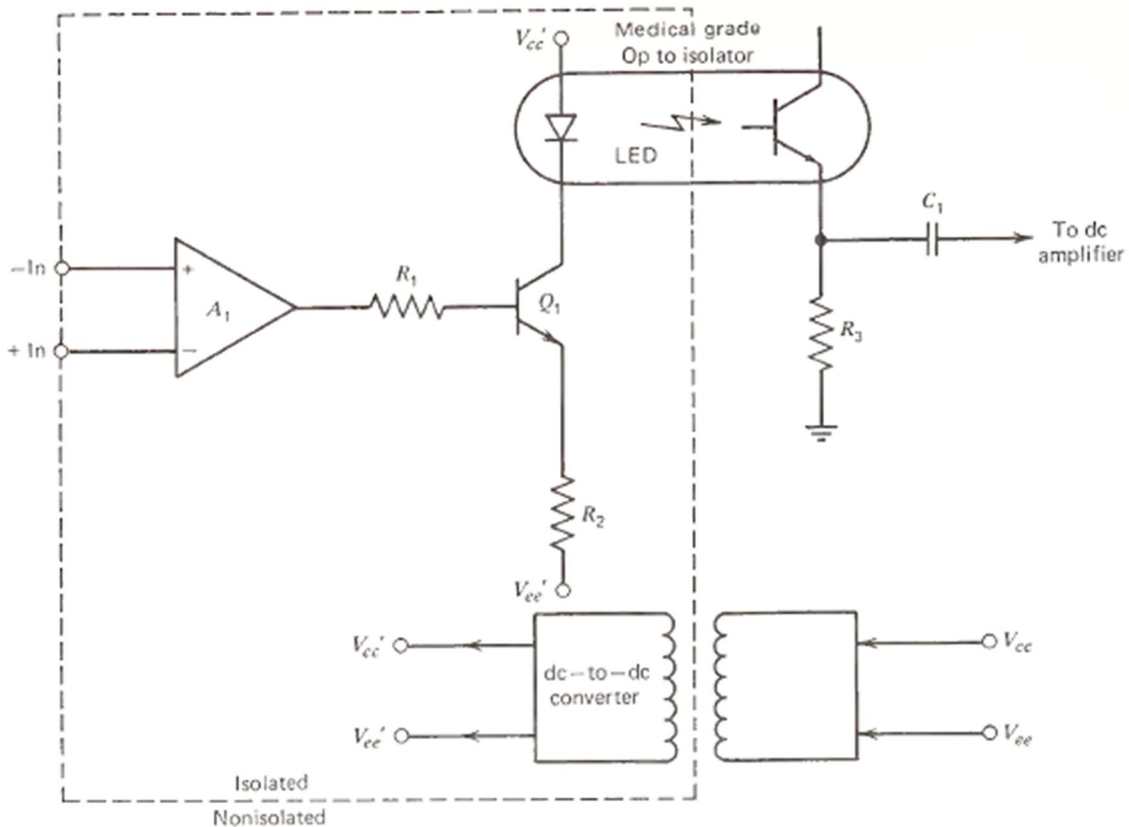

Optically coupled isolation amplifier

- ❑ This circuit uses the same dc to dc converter to power the isolated states as was used in other designs. This will keep A_1 isolated from the ac power mains but is not used in the signal coupling process.
- ❑ The LED in the opto isolator is driven by the output of isolated amplifier A_1 . Transistor Q_1 serves as a series switch to vary the light output of the LED proportional to the analog signal from A_1 .

- ❑ Transistor Q_1 ; normally passes sufficient collector current to bias the LED into a linear portion of its operating curve. The output of the phototransistor is ac coupled to the remaining amplifiers on the non-isolated side of the circuit, so that the offset condition created by LED bias is eliminated.

