

I PROJECTION OF SOLIDS PROBLEMS

Problem 1:

A cylinder 40 mm diameter and 50 mm axis is resting on one point of a base circle on VP while it's axis makes 45° with VP and FV of the axis 35° with HP. Draw its projections.

Solution Steps:

Resting on VP on one point of base, means inclined to VP:

1. Assume it standing on VP
2. It's FV will show True Shape of base & top(circle)
3. Draw 40mm dia. Circle as FV & taking 50 mm axis project TV. (a Rectangle)
4. Name all points as shown in illustration.
5. Draw 2nd TV making axis 45° to xy and project it's FV above xy.
6. Make visible lines dark and hidden dotted, as per the procedure.
7. Then construct remaining inclination with HP (FV of axis i.e. center line of view to xy as shown) & project final.

Solution:

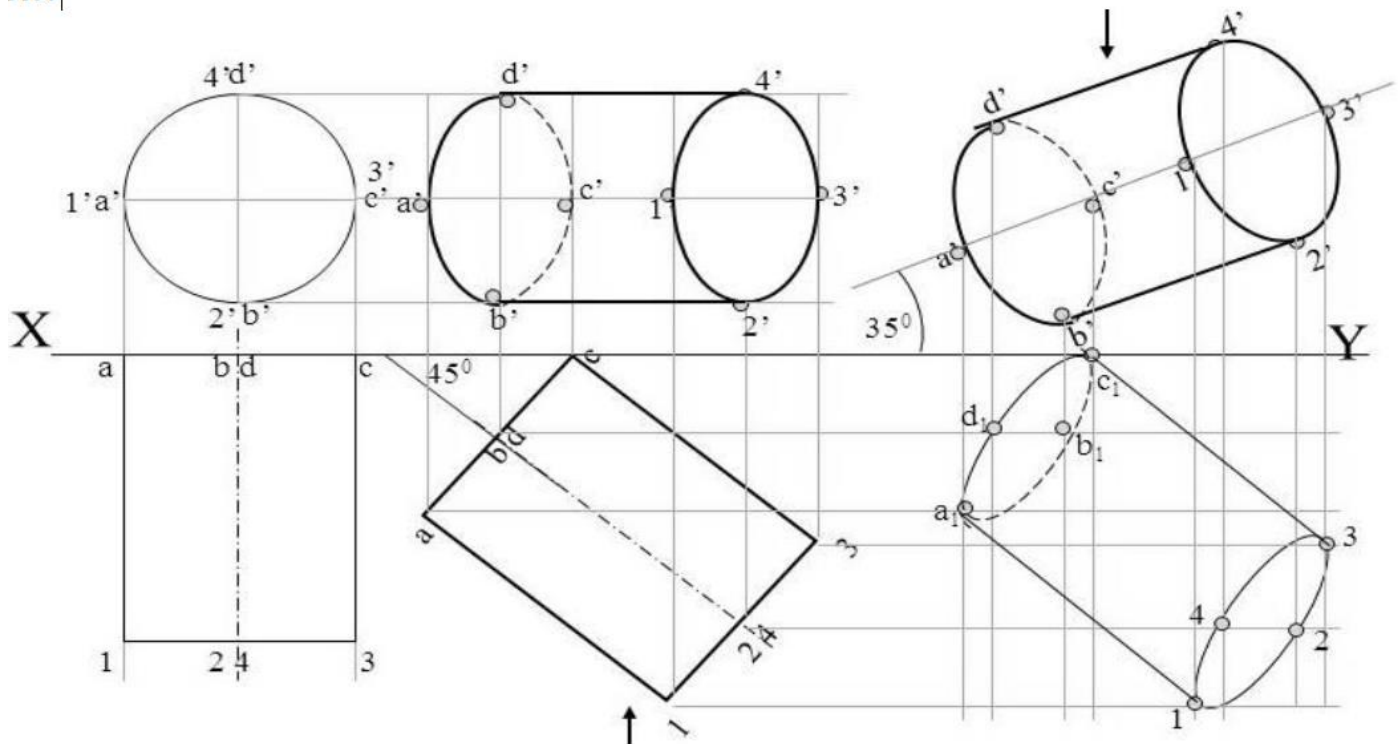

Tips &Shortcuts:

1.Axis inclined to HP and Parallel to VP have to solve in two stages

Stage(i) assume axis perpendicular to HP then draw Top and Front view

Stage(ii) Tilt the Front view according to given angle. Then project all the points will get Final Top view

2 Axis inclined to VP and Parallel to HP have to solve in two stages

Stage(i) assume axis perpendicular to VP then draw front and Top view

Stage(ii) Tilt the Top view according to given angle. Then project all the points will get Final Front view

