

MOMENT AREA METHOD

Fig. shows a beam AB carrying some type of loading, and hence subjected to bending moment as shown in Fig.3.18. Let the beam bent into AP₁Q₁B and due to the load acting on the beam A be a point of zero slope and zero deflection.

Consider an element PQ of small length dx at a distance of x from B. The corresponding points on the deflected beam are P₁Q₁. Let, R = Radius of curvature of deflected beam dθ = Angle included between the tangent P₁ and Q₁ M = Bending moment between P and Q dx = Length of PQ

θ = The angle in radians, included between the tangents drawn at the extremities of the beam i.e., at A and B facing the reference line.

From geometry of the bend up beam Section P₁Q₁, We have

$$P_1Q_1 = R \cdot d\theta$$

$$= dx \cdot dx = R \cdot d\theta$$

$$d\theta = \frac{dx}{R}$$

From bending moment equation.

$$\frac{M}{I} = \frac{E}{R}$$

Or

$$R = \frac{EI}{M}$$

Substituting R value in dθ equation,

$$d\theta = \frac{M}{EI} \cdot dx \quad \dots(i)$$

Since A is point of zero slope at B is obtained by integrating the above equation between the limits 0 and L.

$$\theta = \int_0^L \frac{M}{EI} dx$$

$$= \frac{1}{EI} \int_0^L M \cdot dx$$

We Know that M.dx represents the B.M diagram of length dx.

Hence $\int_0^L M \cdot dx$ is the area of B.M. diagram between A and B. ∴

slope θ = $\frac{1}{EI}$ X Area of B.M diagram between A and B

EI

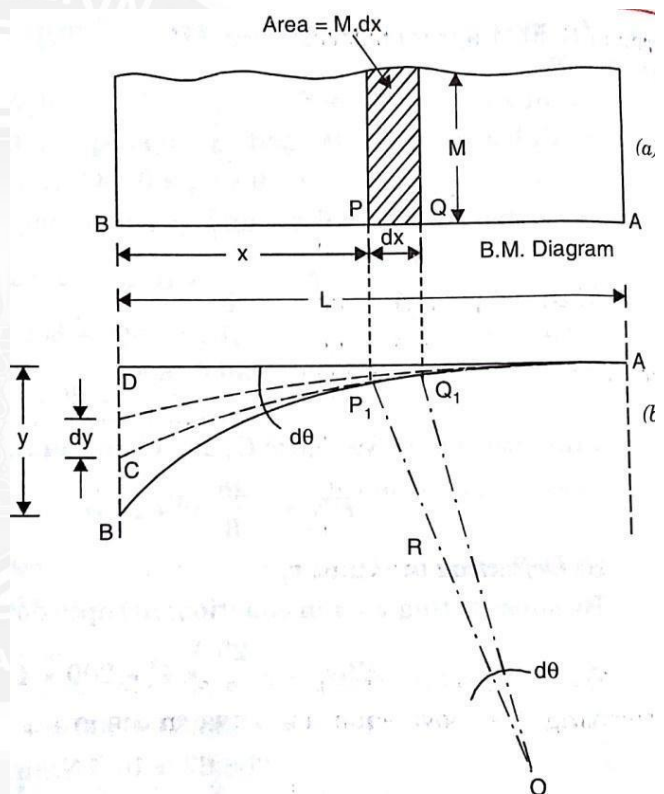

In case, slope at A is not zero, then “Total change of slope between B and A equals the area of B.M diagram between B and A divided by the flexural rigidity EI” . Deflection due to the bending of the portion PQ. $dy = x.d\theta$

Substituting the value of $d\theta$ in equation (i) we get,

$$dy = x \cdot \frac{M}{EI} dx$$

Since the deflection at A is assumed to be zero, the total deflection at B is obtained by integrating the above equation between the limits 0 and L.

$$\begin{aligned} y &= \int_0^L x \frac{M}{EI} dx \\ &= \frac{1}{EI} \int_0^L x \cdot M \cdot dx \end{aligned}$$

But $x.M.dx$ represents the moment of area of the BM diagram of length dx about B. This is equal to the total area of BM diagram multiplied by the distance of the C.G. of the BM diagram area from B.

$$\begin{aligned} y &= \frac{1}{EI} X \bar{x} \times \text{Area of B.M diagram} \\ &= \frac{A\bar{x}}{EI} \end{aligned}$$

Where,

A = Area of BM diagram

X = Distance of C.G of the area from B

In case the point A is not a point of zero slope and deflection

“ The deflection of B with respect to the tangent at A equal to B, the first moment area about B of the area of the B.M diagram between B and A”.

MOHR'S THEOREM 1:

The change of slope between any two points is equal to the net area of the B.M diagram between these points divided by EI

$$\text{Slope } (\theta) = \frac{\text{Area of Bending Moment Diagram}}{EI}$$

MOHR'S THEOREM 2:

The total deflection between any two points is equal to the net moment of area of BM diagram between these points divided by EI.

$$\text{Deflection (y)} = \frac{\text{Area of Bending Moment Diagram} \times \bar{x}}{EI}$$

4.4.3. MAXIMUM SLOPE AND DEFLECTION FOR THE CANTILEVER BEAM WITH A POINT LOAD AT FREE END.

A cantilever beam AB of length L fixed at end A free at end B carrying a point load W at the free end as shown in Fig.

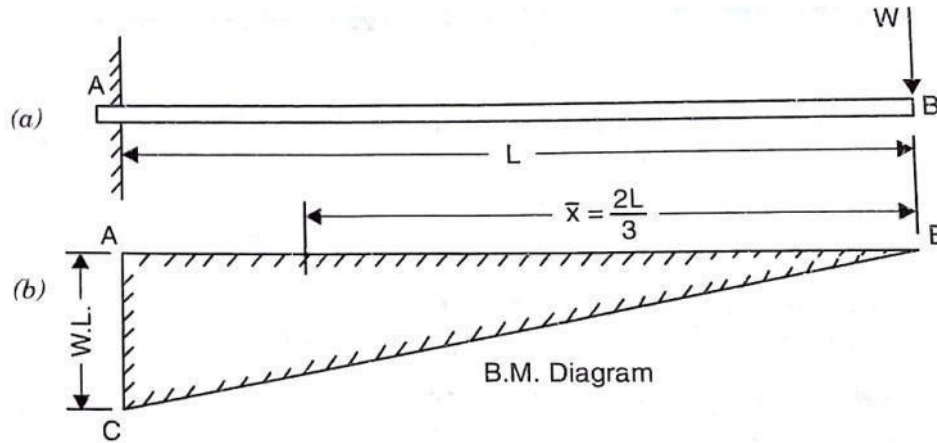

BM at the free end, $B = 0$

BM at the fixed end, $A = -W.L = -WL$

Let, y_B = deflection at end B with respect to A

θ_B = Slope at B

According to Mohr's Theorem I,

$$\text{Slope, } \theta_B = \frac{\text{Area of BM diagram between A and B}}{EI}$$

$$\text{Area of BM diagram} = \frac{1}{2} \cdot L \cdot WL = \frac{WL^2}{2}$$

\therefore Slope at free end $\theta_B = \frac{WL^2}{2EI}$

According to Mohr's Theorem II, Deflection

$$= \frac{A \bar{x}}{EI}$$

y_B 2

\bar{x} from B = $\frac{L}{3}$

$$\text{Deflection at free end } y_B = \frac{\frac{WL^2}{2} \times \frac{2L}{3}}{EI}$$

Deflection

at free end

$$y_B = \frac{WL^3}{3EI}$$

4.4.4. MAXIMUM SLOPE AND DEFLECTION FOR THE CANTILEVER BEAM CARRYING A UNIFORMLY DISTRIBUTED LOAD.

A cantilever beam AB of length L fixed at end A free at end B carrying a uniformly distributed load of w/unit length over the entire length as shown in Fig.

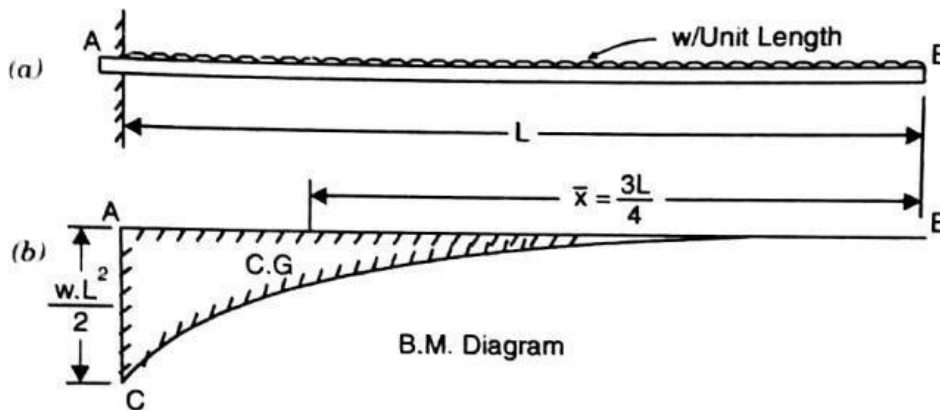

BM at the free end, $B = 0$

BM at the fixed end, $A = -W.L \cdot \frac{L}{2} = -\frac{WL^2}{2}$

Let, $y_B =$ deflection at end B with respect to A

$\theta_B =$ Slope at B

According to Mohr's Theorem I,

Slope, $\theta_B = \frac{\text{Area of BM diagram between A and B}}{EI}$

Area of BM diagram $= \frac{1}{3} \times L \times \frac{WL^2}{2} = \frac{WL^3}{6}$

\therefore Slope at free end $\theta_B = \frac{WL^3}{6EI}$

According to Mohr's Theorem II, Deflection

$y_B = \frac{A \bar{x}}{EI}$

\bar{x} from B $= \frac{3}{4}L$

Deflection $y_B = \frac{\frac{WL^3}{6} \times \frac{3L}{4}}{EI}$

$y_B = \frac{WL^4}{8EI}$

4.4.5. Maximum slope and Deflection for the Cantilever beam carrying a uniformly

distributed load upto a length 'a' from the fixed end.

A cantilever beam AB of length L fixed at end A free at end B carrying a uniformly distributed load of w/unit length up to a length of 'a' from the fixed end as shown in Fig.

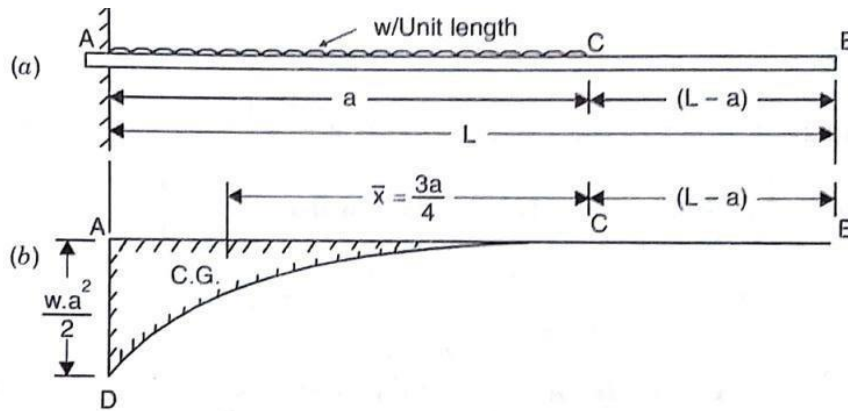

BM at the free end, $B = 0$ BM at C

= 0

BM at the fixed end, $A = -W.a.\frac{a}{2} = -\frac{Wa^2}{2}$

Let, $y_B =$ deflection at end B with respect to A $\theta_B =$ Slope at B

According to Mohr's Theorem I,

Slope, $\theta_B = \frac{\text{Area of BM diagram between A and B}}{EI}$

Area of BM diagram $= \frac{1}{3} \times a \times \frac{Wa^2}{2} = \frac{Wa^3}{6}$

\therefore Slope at free end $\theta_B = \frac{Wa^3}{6EI}$

According to Mohr's Theorem II, Deflection

$y_B = \frac{A \bar{x}}{EI}$

\bar{x} from B $= (L - a) + \frac{3}{4}a$

Deflection $y_B = \frac{\frac{Wa^3}{6} \times \left[(L - a) + \frac{3a}{4} \right]}{EI}$

Deflection at free end,

$y_B = \frac{Wa^3}{6EI} \left[(L - a) + \frac{3a}{4} \right]$

4.4.6. MAXIMUM SLOPE AND DEFLECTION FOR THE SIMPLY SUPPORTED BEAM WITH A CENTRAL POINT LOAD.

A Simply supported beam AB of length L carrying a point load W at the centre of the beam (i.e., at a point C) as shown in Fig.

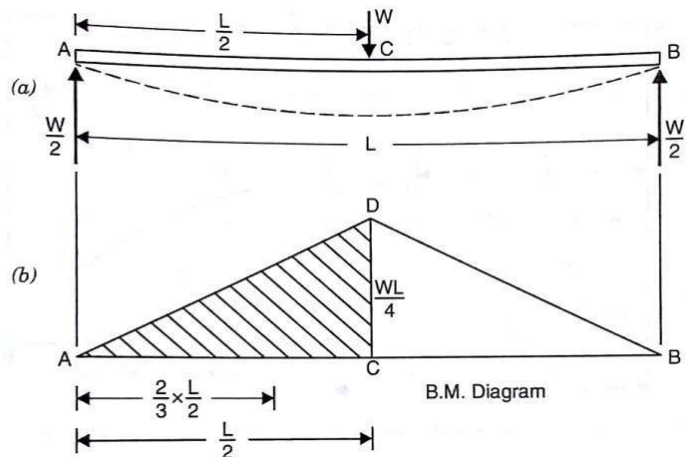

Since the beam is symmetrically loaded,

$$R_A = R_B = \frac{\text{Total load}}{2} = \frac{W}{2}$$

BM at the ends A and B = 0 (since A and B are simply supported ends)

$$\text{BM at Centre, } C = R_A \cdot \frac{L}{2} = \frac{W}{2} \cdot \frac{L}{2} = \frac{WL}{4}$$

Let, $y_c =$ deflection at the centre. $\theta_A = \theta_B =$

Slope at Supports. A and B.

According to Mohr's Theorem I,

$$\text{Slope, } \theta_A = \theta_B = \frac{\text{Area of BM diagram between A and C}}{EI}$$

$$\text{Area of BM diagram} = \frac{1}{2} \cdot \frac{L}{2} \cdot \frac{WL}{4} = \frac{WL^2}{16}$$

$$\therefore \text{Slope at Supports } \theta_A = \theta_B = \frac{WL^2}{16EI}$$

According to Mohr's Theorem II,

$$\text{Deflection at centre } y_c = \frac{A \bar{x}}{EI}$$

$$\bar{x} \text{ from A} = \frac{2L}{3} = \frac{2L}{6}$$

$$\text{Deflection } y_c = \frac{\frac{WL^2}{16} \times \frac{2L}{6}}{EI}$$

$$\text{Deflection at centre } y_c = \frac{WL^3}{48EI}$$

4.4.7. MAXIMUM SLOPE AND DEFLECTION FOR THE SIMPLY SUPPORTED BEAM WITH UNIFORMLY DISTRIBUTED LOAD.

A Simply supported beam AB of length L carrying a udl of w/unit length as shown in Fig.

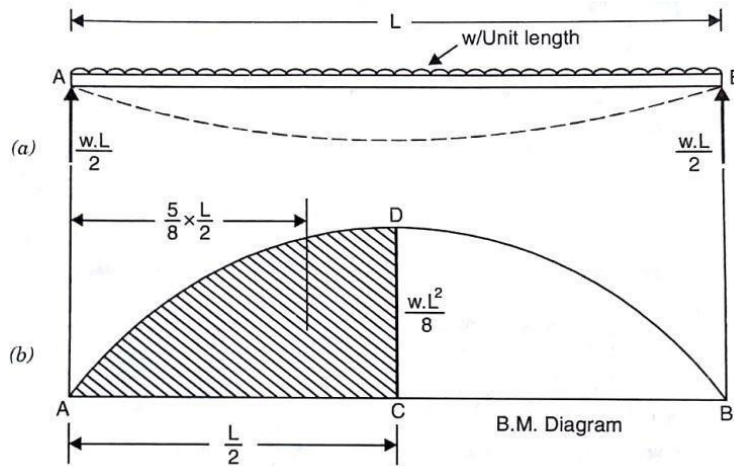

Since the beam is symmetrically loaded,

$$R_A = R_B = \frac{\text{Total load}}{2} = \frac{wL}{2}$$

BM at the ends A and B = 0 (since A and B are simply supported ends)

$$\text{BM at Centre, } C = R_A \cdot \frac{L}{2} - \frac{wL}{2} \cdot \frac{L}{4} = \frac{wL}{2} \cdot \frac{L}{2} - \frac{wL^2}{8} = \frac{wL^2}{8}$$

Let, y_c = deflection at the centre. C θ_A

= θ_B = Slope at Supports. A and B. According to Mohr's Theorem

I,

$$\text{Slope, } \theta_A = \theta_B = \frac{\text{Area of BM diagram between A and C}}{EI}$$

$$\text{Area of BM diagram} = \frac{2}{3} \cdot \frac{L}{2} \cdot \frac{wL^2}{8} = \frac{wL^3}{24}$$

$$\therefore \text{Slope at Supports } \theta_A = \theta_B = \frac{wL^3}{24EI}$$

According to Mohr's Theorem II,

$$\text{Deflection at centre } y_c = \frac{A \bar{x}}{EI}$$

$$\bar{x} \text{ from A} = \frac{5L}{8} = \frac{5L}{16}$$

$$\text{Deflection } y_c = \frac{\frac{wL^3}{24} \times \frac{5L}{16}}{EI}$$

$$\text{Deflection at centre } y_c = \frac{5wL^4}{384EI}$$

Example.3.4.1. A cantilever beam of 4m long carries a point load of 9kN at the free end and an UDL of 8kN/m over a length of 2m from the fixed end. Determine the maximum slope and deflection by area moment method. Take $E = 2.2 \times 10^5 \text{Mpa}$ and $I = 22.5 \times 10^6 \text{mm}^4$.

Given Data:

Span, $L = 4\text{m}$

Point load at free end $W = 9\text{KN}$

Udl, $w = 8\text{kN/m}$ over a length of 2m from the fixed end

Young's Modulus, $E = 2.2 \times 10^5 \text{Mpa}$
 $= 2.2 \times 10^5 \times 10^6 \text{pa}$
 $= 2.2 \times 10^5 \times 10^6 \text{N/m}^2$
 $= 2.2 \times 10^5 \times \frac{10^6}{10^6} = 2.2 \times 10^5 \text{N/mm}^2$

Moment of Inertia $I = 22.5 \times 10^6 \text{mm}^4$.

To Find

The maximum slope and deflection

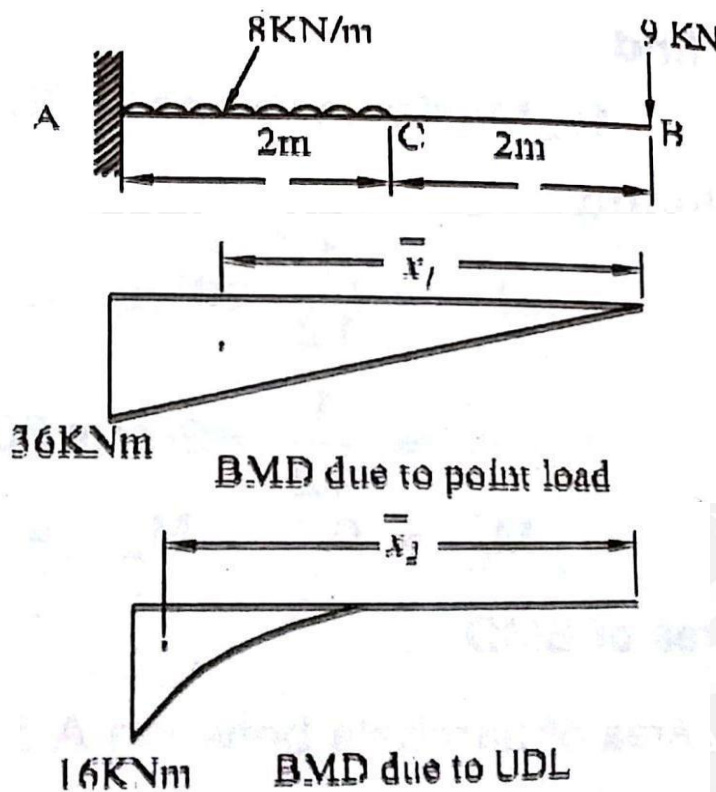

Solution Bending moments

Due to point load,

$$M_B = 0 \quad M_A = -9 \times 4 = -36\text{kNm}$$

Due to UDL

$$M_B = M_C = 0 \quad M_A = -8 \times 2 \times \frac{4}{2} = -16\text{ kNm}$$

Area of BMD

Area of BMD due to point load,

$$A^1 = \frac{1}{2} \times 4 \times 36$$

$$=72\text{kNm}^2 = 72 \times 10^9 \text{ Nmm}^2. \text{ Area of BMD}$$

due to UDL,

$$\begin{aligned} A_2 &= \frac{1}{3} \times 2 \times 16 \\ &= 10.67 \text{ kNm}^2 = 10.67 \times 10^9 \text{ Nmm}^2 \end{aligned}$$

Centroidal distances from free end

$$\begin{aligned} \bar{x}_1 &= \frac{2}{3} \times 4 = 2.67\text{m} = 2.67 \times 10^3 \text{ mm} \\ \bar{x}_2 &= 2 + \frac{3}{4} \times 2 = 3.5\text{m} = 3.5 \times 10^3 \text{ mm} \end{aligned}$$

Maximum slope

Applying Mohr's Theorem I

Maximum slope at free end,

$$\begin{aligned} \theta_B &= \frac{\text{Area of BMD}}{EI} = \frac{A_1 + A_2}{EI} \\ &= \frac{(72 + 10.67) \times 10^9}{(2.2 \times 10^5 \times 22.5 \times 10^6)} \end{aligned}$$

= **0.0167 radians Maximum Deflection**

Applying Mohr's Theorem II

Maximum Deflection at free end,

$$\begin{aligned} y_B &= \frac{(\text{Area of BMD}) \bar{x}}{EI} \\ &= \frac{A_1 \bar{x}_1 + A_2 \bar{x}_2}{EI} \\ &= \frac{(72 \times 10^9 \times 2.67 \times 10^3) + (10.67 \times 10^9 \times 3.5 \times 10^3)}{(2.2 \times 10^5 \times 22.5 \times 10^6)} \\ &= \mathbf{46.38\text{mm}.} \end{aligned}$$

Example.3.4.2. A Cantilever of 4m span carries a UDL of 20 kN/m run spread over its entire length. In addition to UDL it carries a concentrated load of 30 kN at the free end.

Calculate the slope and deflection at the free end by moment area method. Take $E = 2 \times 10^5 \text{ N/mm}^2$ and $I = 8 \times 10^7 \text{ mm}^4$.

Given Data:

Span,	$L = 4\text{m}$
Udl,	$w = 20\text{kN/m}$ Point load at
free end	$W = 30\text{KN}$
Young's Modulus,	$E = 2 \times 10^5 \text{ N/mm}^2$

Moment of Inertia $I = 8 \times 10^7 \text{ mm}^4$.

To Find

The maximum slope and deflection

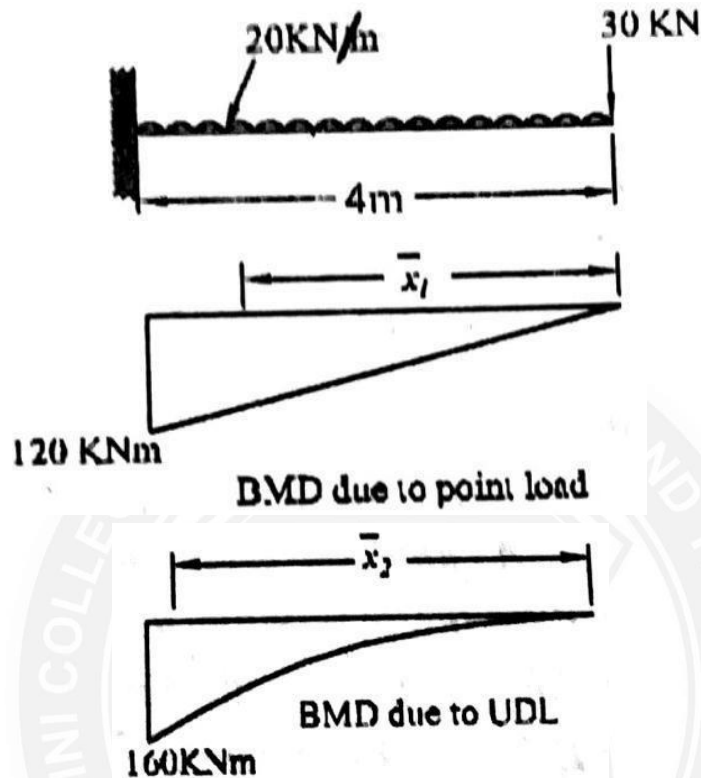

Solution

Bending moments

Due to point load,

$$M_B = 0 \quad M_A = -30 \times 4 = -120 \text{ kNm}$$

Due to UDL

$$M_B = 0 \quad M_A = -20 \times 4 \times \frac{4}{2} = -160 \text{ kNm}$$

Area of BMD

Area of BMD due to point load,

$$\begin{aligned} A^1 &= \frac{1}{2} \times 4 \times 120 \\ &= 240 \text{ kNm}^2 = 240 \times 10^9 \text{ Nmm}^2. \end{aligned}$$

Area of BMD

due to UDL,

$$\begin{aligned} A^2 &= \frac{1}{3} \times 4 \times 160 \\ &= 213.33 \text{ kNm}^2 = 213.33 \times 10^9 \text{ Nmm}^2 \end{aligned}$$

Centroidal distances from free end

$$\bar{x}_1 = \frac{2}{3} \times 4 = 2.67 \text{ m} = 2.67 \times 10^3 \text{ mm}$$

$$\bar{x}_2 = \frac{3}{4} \times 4 = 3 \text{ m} = 3 \times 10^3 \text{ mm}$$

Maximum slope

Applying Mohr's Theorem I

Maximum slope at free end,

$$\theta_B = \frac{\text{Area of BMD}}{EI} = \frac{A_1 + A_2}{EI}$$

$$= \frac{(240 + 213.33) \times 10^9}{(2 \times 10^5 \times 8 \times 10^7)} = \mathbf{0.0283 \text{ radians Maximum Deflection}}$$

Applying Mohr's Theorem II Maximum

Deflection at free end,

$$y_B = \frac{(\text{Area of BMD}) \times \bar{x}}{EI}$$

$$= \frac{A_1 \bar{x}_1 + A_2 \bar{x}_2}{EI}$$

$$= \frac{(240 \times 10^9 \times 2.67 \times 10^3) + (213.33 \times 10^9 \times 3 \times 10^3)}{(2 \times 10^5 \times 8 \times 10^7)} = \mathbf{80 \text{ mm.}}$$

Example.3.4.3. A simply supported beam of hollow circular section of external diameter 200mm and internal diameter 150mm has a span of 6m. It is subjected to a central concentrated load of 50kN and a UDL of 5kN/m over the entire span. Determine the maximum slope at supports and maximum deflection at centre. Take $E = 2 \times 10^5 \text{ N/mm}^2$.

Given Data:

External diameter, $D = 200 \text{ mm}$

Internal diameter, $d = 150 \text{ mm}$

Span, $L = 6 \text{ m}$

Central point load $W = 50 \text{ kN}$

Udl $w = 5 \text{ kN/m}$

Young's Modulus, $E = 2 \times 10^5 \text{ N/mm}^2$

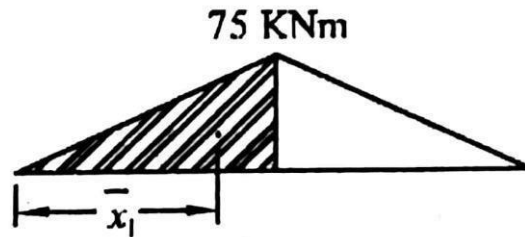
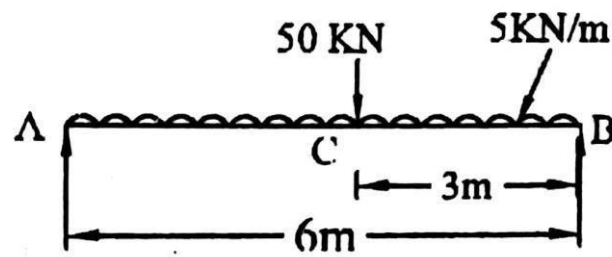

BMD due to Point load

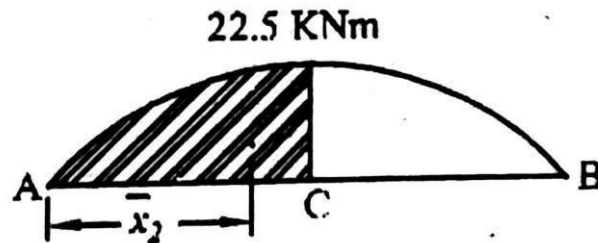

B.M.D due to UDL

To Find

The maximum slope and deflection

Solution Bending moments

Moment of inertia for a hollow circular section,

$$\begin{aligned} I &= \frac{\pi}{64} (D^4 - d^4) \\ &= \frac{\pi}{64} (200^4 - 150^4) \\ &= 53.69 \times 10^6 \text{ mm}^4 \end{aligned}$$

Bending Moments

Due to point load, B.M at supports,

$$M_A = M_B = 0 \text{ (since A and B are simply supported)}$$

$$\begin{aligned} \text{B.M at centre, } M_C &= \frac{WL}{4} \\ &= \frac{50 \times 6}{4} = 75 \text{ kNm} = 75 \times 10^6 \text{ Nmm} \end{aligned}$$

Due to UDL, B.M at supports,

$$M_A = M_B = 0 \text{ (since A and B are simply supported)}$$

$$\begin{aligned} \text{B.M at centre, } M_C &= \frac{wL^2}{8} \\ &= \frac{50 \times 6^2}{8} = 22.5 \text{ kNm} = 22.5 \times 10^6 \text{ Nmm} \end{aligned}$$

Area of BMD

Area of BMD due to point load,

$$A^1 = \frac{1}{2} \times 3 \times 75$$

$$= 112.5 \text{ kNm}^2 = 112.5 \times 10^9 \text{ Nmm}^2. \text{ Area of BMD}$$

due to UDL,

$$A^2 = \frac{2}{3} \times 3 \times 22.5$$

$$= 45 \text{ kNm}^2 = 45 \times 10^9 \text{ Nmm}^2$$

Centroidal distances from free end

$$\bar{x}_1 = \frac{2}{3} \times 3 = 2\text{m} = 2 \times 10^3 \text{ mm}$$

$$\bar{x}_2 = \frac{5}{8} \times 3 = 1.875\text{m} = 1.875 \times 10^3 \text{ mm}$$

Maximum slope

Applying Mohr's Theorem I Maximum slope at

Supports,

$$\theta_A = \theta_B = \frac{\text{Area of BMD}}{EI} = \frac{A_1 + A_2}{EI}$$

$$= \frac{(112.5 + 45) \times 10^9}{(2 \times 10^5 \times 53.69 \times 10^6)} = \mathbf{0.0147 \text{ radians Maximum Deflection}}$$

Applying Mohr's Theorem II

Maximum Deflection at Centre,

$$y_c = \frac{(\text{Area of BMD}) \times \bar{x}}{EI}$$

$$= \frac{A_1 \bar{x}_1 + A_2 \bar{x}_2}{EI}$$

$$= \frac{(112.5 \times 10^9 \times 2 \times 10^3) + (45 \times 10^9 \times 1.875 \times 10^3)}{(2 \times 10^5 \times 53.69 \times 10^6)} = \mathbf{28.81 \text{ mm}}$$