

**ROHINI COLLEGE OF ENGINEERING AND TECHNOLOGY**



**ROHINI**

**COLLEGE OF ENGINEERING AND TECHNOLOGY**

Approved by AICTE and affiliated to Anna University, (An ISO Certified Institution)

Accredited by NAAC with A+ Grade

**DEPARTMENT OF AGRICULTURAL ENGINEERING**

**AI3402 SOIL AND WATER CONSERVATION ENGINEERING**

**Mr. VENKATESHAN P**

**ASSISTANT PROFESSOR**

**AI3402 SOIL AND WATER CONSERVATION ENGINEERING**

## Types of Water Harvesting

**Rainwater Harvesting:** Rainwater harvesting is defined as the method for inducing, collecting, storing and conserving local surface runoff for agriculture in arid and semi-arid regions. Three types of water harvesting are covered by rainwater harvesting.

- Water collected from roof tops, courtyards and similar compacted or treated surfaces is used for domestic purpose or garden crops.
- Micro-catchment water harvesting is a method of collecting surface runoff from a small catchment area and storing it in the root zone of an adjacent infiltration basin. The basin is planted with a tree, a bush or with annual crops.
- Macro-catchment water harvesting, also called harvesting from external catchments is the case where runoff from hill-slope catchments is conveyed to the cropping area located at foothill on flat terrain.

**Flood Water Harvesting:** Flood water harvesting can be defined as the collection and storage of creek flow for irrigation use. Flood water harvesting, also known as 'large catchment water harvesting' or 'Spate Irrigation', may be classified into following two forms:

- In case of 'flood water harvesting within stream bed', the water flow is dammed and as a result, inundates the valley bottom of the flood plain. The water is forced to infiltrate and the wetted area can be used for agriculture or pasture improvement.
- In case of 'flood water diversion', the wadi water is forced to leave its natural course and conveyed to nearby cropping fields.

**Groundwater Harvesting:** Groundwater harvesting is a rather new term and employed to cover traditional as well as unconventional ways of ground water extraction. Qanat systems, underground dams and special types of wells are a few examples of the groundwater harvesting techniques. Groundwater dams like 'Subsurface Dams' and 'Sand Storage Dams' are other fine examples of groundwater harvesting. They obstruct the flow of ephemeral streams in a river bed; the water is stored in the sediment below ground surface and can be used for aquifer recharge.

## Water Harvesting Technique

This includes runoff harvesting, flood water harvesting and groundwater harvesting.

### Runoff Harvesting

Runoff harvesting for short and long term is done by constructing structures as given below.

#### Short Term Runoff Harvesting Techniques

**Contour Bunds:** This method involves the construction of bunds on the contour of the catchment area (Fig. 28.1). These bunds hold the flowing surface runoff in the area located between two adjacent bunds. The height of contour bund generally ranges from 0.30 to 1.0 m

and length from 10 to a few 100 meters. The side slope of the bund should be as per the requirement. The height of the bund determines the storage capacity of its upstream area.

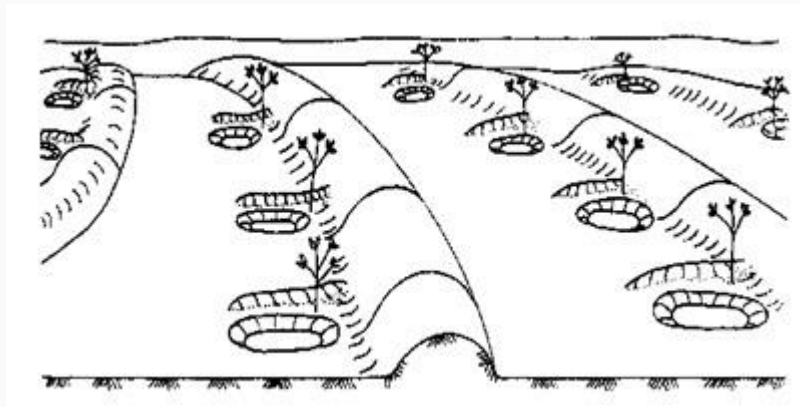

**Fig. 28.1. Contour Bunds. (Source: Barron and Salas, 2009)**

**Semicircular Hoop:** This type of structure consists of an earthen impartment constructed in the shape of a semicircle (Fig. 28.2). The tips of the semicircular hoop are furnished on the contour. The water contributed from the area is collected within the hoop to a maximum depth equal to the height of the embankment. Excess water is discharged from the point around the tips to the next lower hoop. The rows of semicircular hoops are arranged in a staggered form so that the over flowing water from the upper row can be easily interrupted by the lower row. The height of hoop is kept from 0.1 to 0.5 m and radius varies from 5 to 30 m. Such type of structure is mostly used for irrigation of grasses, fodder, shrubs, trees etc.

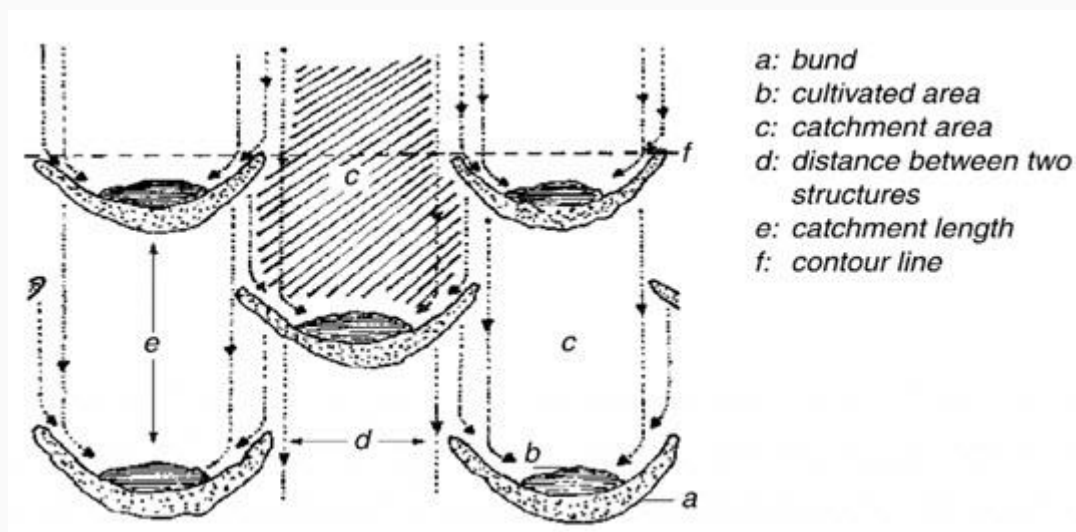

**Fig. 28.2. Layout of Semi-Circular Hoop. (Source: Barron and Salas 2009)**

**Trapezoidal Bunds:** Such bunds also consist of an earthen embankment, constructed in the shape of trapezoids. The tips of the bund wings are placed on the contour. The runoff water yielded from the watershed is collected into the covered area. The excess water overflows around the tips. In this system of water harvesting the rows of bunds are also arranged in staggered form to intercept the overflow of water from the adjacent upstream areas. The layout of the trapezoidal bunds is the same as the semicircular hoops, but they unusually cover a larger area (Fig. 28.3). Trapezoidal bund technique is suitable for the areas where the rainfall intensity

is too high and causes large surface flow to damage the contour bunds. This technique of water harvesting is widely used for irrigating crops, grasses, shrubs, trees etc.

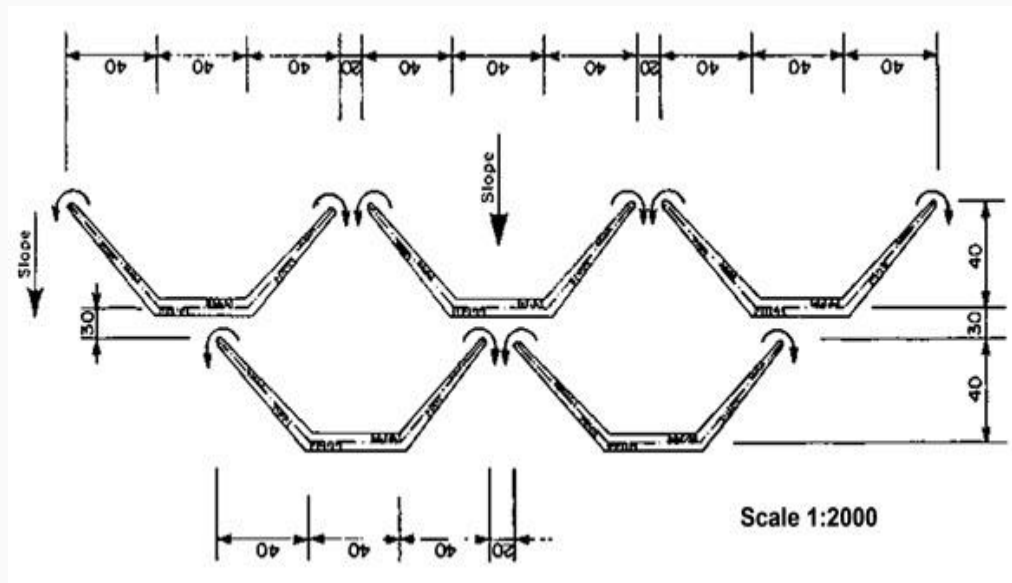

**Fig. 28.3. Layout of Trapezoidal Bund. (Source: Barron and Salas, 2009)**

**Graded Bunds:** Graded bunds also referred as off contour bunds. They consist of earthen or stone embankments and are constructed on a land with a slope range of 0.5 to 2%. The design and construction of graded bunds are different from the contour bunds. They are used as an option where rainfall intensity and soils are such that the runoff water discharged from the field can be easily intercepted. The excess intercepted or harvested water is diverted to the next field through a channel ranges. The height of the graded bund ranges from 0.3 to 0.6 m. The downstream bunds consist of wings to intercept the overflowing water from the upstream bunds. Due to this, the configuration of the graded bund looks like an open ended trapezoidal bund. That is why sometimes it is also known as modified trapezoidal bund. This type of bunds for water harvesting is generally used for irrigating the crops.

**Rock Catchment:** The rock catchments are the exposed rock surfaces, used for collecting the runoff water in a part as depressed area. The water harvesting under this method can be explained as: when rainfall occurs on the exposed rock surface, runoff takes place very rapidly because there is very little loss. The runoff so formed is drained towards the lowest point called storage tank and the harvested water is stored there. The area of rock catchment may vary from a 100 m<sup>2</sup> to few 1000 m<sup>2</sup>; accordingly the dimensions of the storage tank should also be designed. The water collected in the tank can be used for domestic use or irrigation purposes.

**Ground Catchment:** In this method, a large area of ground is used as catchment for runoff yield. The runoff is diverted into a storage tank where it is stored. The ground is cleared from vegetation and compacted very well. The channels are as well compacted to reduce the seepage or percolation loss and sometimes they are also covered with gravel. Ground catchments are also called roaded catchments. This process is also called runoff inducement. Ground catchments have also been traditionally used since last 4000 years in the Negev (a desert in southern Israel) where annul crops and some drought tolerant species like pistachio dependent on such harvested water are grown.

### Long Term Runoff Harvesting Techniques

The long term runoff harvesting is done for building a large water storage for the purpose of irrigation, fish farming, electricity generation etc. It is done by constructing reservoirs and big ponds in the area. The design criteria of these constructions are given below.

- Watershed should contribute a sufficient amount of runoff.
- There should be suitable collection site, where water can be safely stored.
- Appropriate techniques should be used for minimizing various types of water losses such as seepage and evaporation during storage and its subsequent use in the watershed.
- There should also be some suitable methods for efficient utilization of the harvested water for maximizing crop yield per unit volume of available water.

The most common long term runoff harvesting structures are:

- Dugout Ponds
- Embankment Type Reservoirs

**Dugout Ponds:** The dugout ponds are constructed by excavating the soil from the ground surface. These ponds may be fed by ground water or surface runoff or by both. Construction of these ponds is limited to those areas which have land slope less than 4% and where water table lies within 1.5-2 meters depth from the ground surface (Fig. 28.4). Dugout ponds involve more construction cost, therefore these are generally recommended when embankment type ponds are not economically feasible. The dugout ponds can also be recommended where maximum utilization of the harvested runoff water is possible for increasing the production of some important crops. This type of ponds require brick lining with cement plastering to ensure maximum storage by reducing the seepage loss.

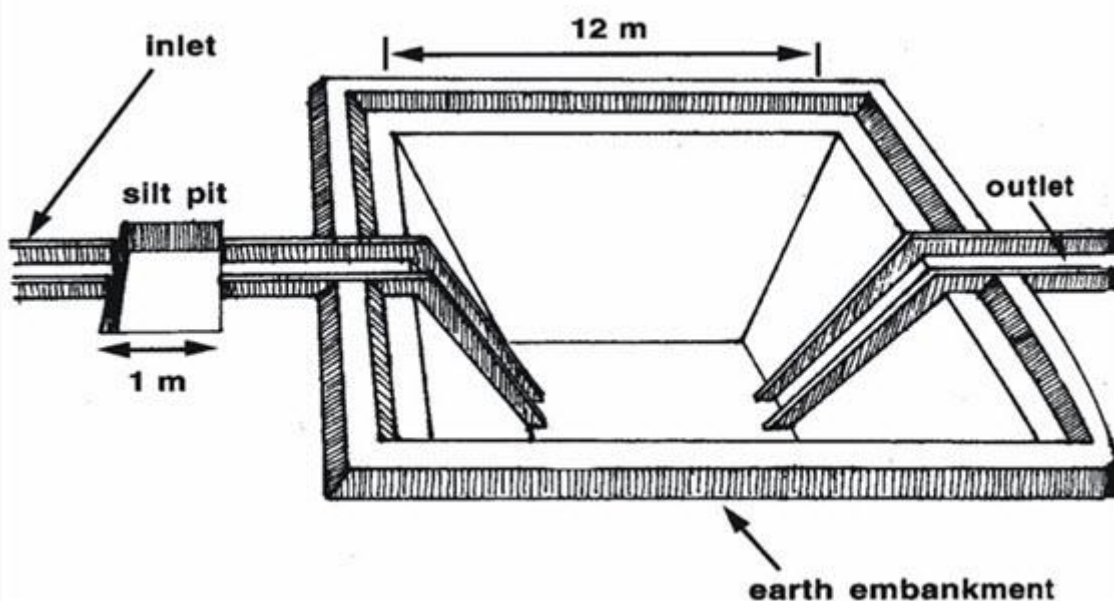

Fig. 28.4. Illustration of Dugout Pond. (Source: Barron and Salas, 2009)

**Embankment Type Reservoir:** These types of reservoirs are constructed by forming a dam or embankment on the valley or depression of the catchment area. The runoff water is collected into this reservoir and is used as per requirement. The storage capacity of the reservoir is determined on the basis of water requirement for various demands and available surface runoff from the catchment. In a situation when heavy uses of water are expected, then the storage capacity of the reservoir must be kept sufficient so that it can fulfill the demand for more than one year.

Embankment type reservoirs are again classified as given below according to the purpose for which they are meant.

**Irrigation Dam:** The irrigation dams are mainly meant to store the surface water for irrigating the crops. The capacity is decided based on the amount of input water available and output water desired. These dams have the provisions of gated pipe spillway for taking out the water from the reservoir. Spillway is located at the bottom of the dam leaving some minimum dead storage below it.

**Silt Detention Dam:** The basic purpose of silt detention dam is to detain the silt load coming along with the runoff water from the catchment area and simultaneously to harvest water. The silt laden water is stored in the depressed part of the catchment where the silt deposition takes place and comparatively silt free water is diverted for use. Such dams are located at the lower reaches of the catchment where water enters the valley and finally released into the streams. In this type of dam, provision of outlet is made for taking out the water for irrigation purposes. For better result a series of such dams can be constructed along the slope of the catchment.

**High Level Pond:** Such dams are located at the head of the valley to form the shape of a water tank or pond. The stored water in the pond is used to irrigate the area lying downstream. Usually, for better result a series of ponds can be constructed in such a way that the command area of the tank located upstream forms the catchment area for the downstream tank. Thus all but the uppermost tanks are facilitated with the collection of runoff and excess irrigation water from the adjacent higher catchment area.

**Farm Pond:** Farm ponds are constructed for multi-purpose objectives, such as for irrigation, live-stock, water supply to the cattle feed, fish production etc. The pond should have adequate capacity to meet all the requirements. The location of farm pond should be such that all requirements are easily and conveniently met.

**Water Harvesting Pond:** The farm ponds can be considered as water harvesting ponds. They may be dugout or embankment type. Their capacity depends upon the size of catchment area. Runoff yield from the catchment is diverted into these ponds, where it is properly stored. Measures against seepage and evaporation losses from these ponds should also be.

**Percolation Dam:** These dams are generally constructed at the valley head, without the provision of checking the percolation loss. Thus, a large portion of the runoff is stored in the soil. The growing crops on downstream side of the dam, receive the percolated water for their growth.

### **Flood Water Harvesting**

To harvest flood water, wide valleys are reshaped and formed into a series of broad level terraces and the flood water is allowed to enter into them. The flood water is spread on these

terraces where some amount of it is absorbed by the soil which is used later on by the crops grown in the area. Therefore, it is often referred to as "Water Spreading" and sometimes "Spate Irrigation". The main characteristics of water spreading are:

- Turbulent channel flow is harvested either (a) by diversion or (b) by spreading within the channel bed/valley floor.
- Runoff is stored in soil profile.
- It has usually a long catchment (may be several km)
- The ratio between catchment to cultivated area lies above 10:1.
- It has provision for overflow of excess water.

The typical examples of flood water harvesting through water spreading are given below.

### Permeable Rock Dams (for Crops)

These are long low rock dams across valleys slowing and spreading floodwater as well as healing gullies (Fig. 28.5). These are suitable for a situation where gently sloping valleys are likely to transform into gullies and better water spreading is required.

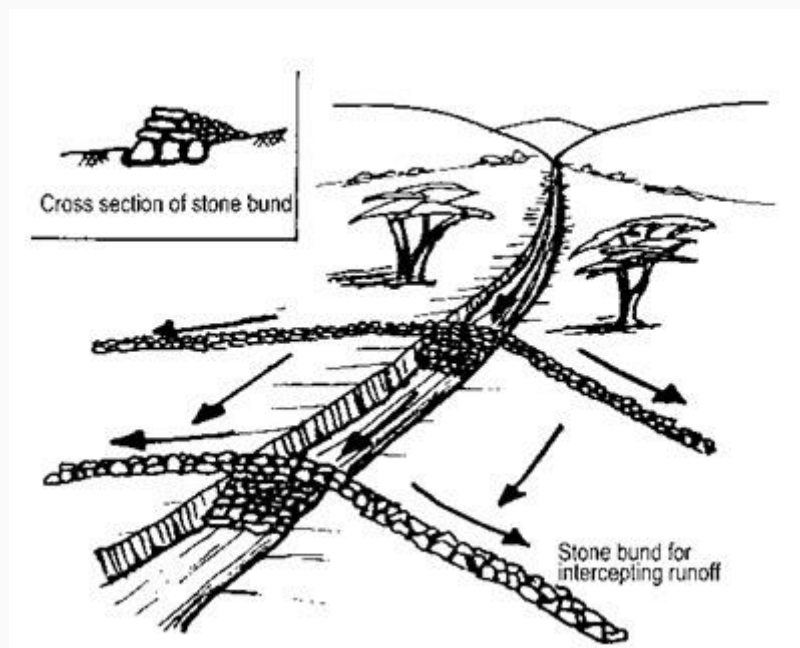
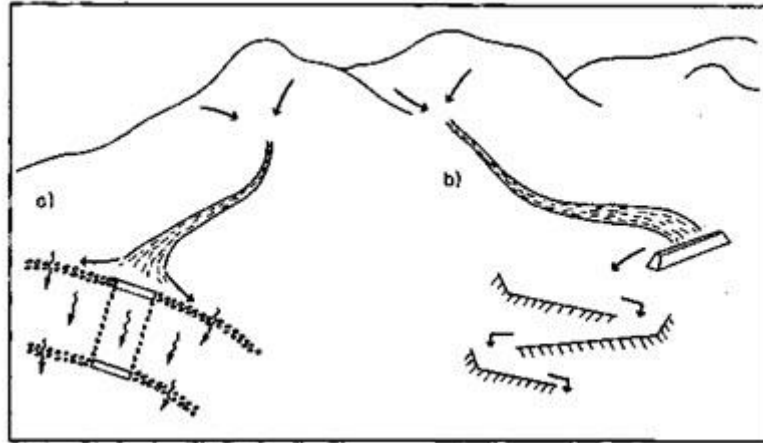

Fig. 28.5. Permeable Rock Dams. (Source: Barron and Salas, 2009)

**Water Spreading Bunds (for Crops and Rangeland):** In this method, runoff water is diverted to the area covered by graded bund by constructing diversion structures such as diversion drains. They lead to the basin through channels, where crops are irrigated by flooding. Earthen bunds are set at a gradient, with a "dogleg" shape and helps in spreading diverted floodwater (Fig. 28.6). These are constructed in arid areas where water is diverted from watercourse onto crop or fodder block.



**Fig. 28.6. Floodwater farming systems: (a) spreading within channel bed; (b) diversion system. (Source: Barron and Salas, 2009)**

**Flood Control Reservoir:** The reservoirs constructed at suitable sites for controlling the flood are known as flood control reservoirs. They are well equipped with self-operating mechanical outlets for letting out the harvested water into the stream or canal below the reservoir as per requirement.

### Groundwater Harvesting

**Qanat System:** A qanat consists of a long tunnel or conduit leading from a well dug at a reliable source of groundwater (the mother well). Often, the mother well is dug at the base of a hill or in the foothills of a mountain range. The tunnel leading from the mother well slopes gradually downward to communities in the valley below. Access shafts are dug intermittently along the horizontal conduit to allow for construction and maintenance of the qanat (Fig. 28.7). The Qanat system was used widely across Persia and the Middle East for many reasons. First, the system requires no energy, relies on the force of gravity alone. Second, the system can carry water across long distances through subterranean chambers avoiding leakage, evaporation, or pollution. And lastly, the discharge is fixed by nature, producing only the amount of water that is distributed naturally from a spring or mountain, ensuring that the water table is not depleted. More importantly, it allows access to a reliable and plentiful source of water to those living in otherwise marginal landscapes (Fig. 28.8).



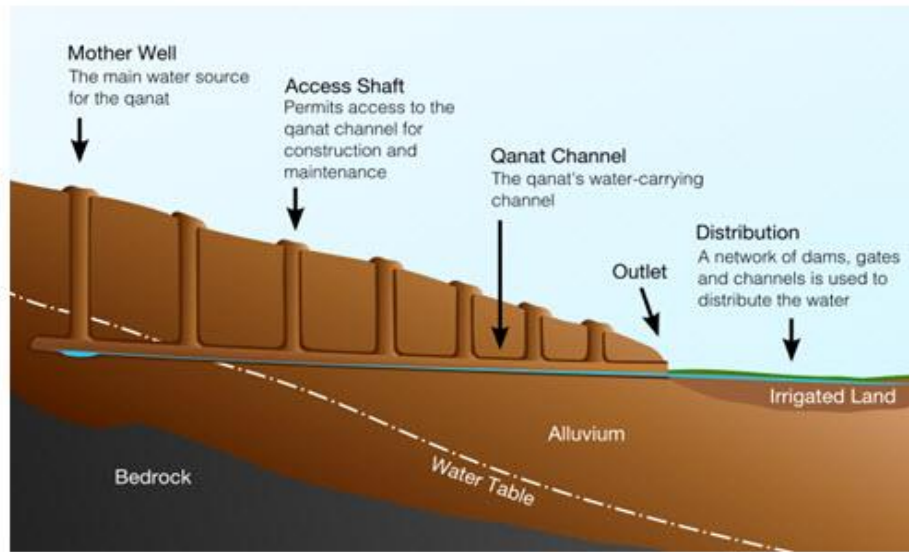

Fig. 28.7. Cross Section Showing Qanats. (Source: Barron and Salas, 2009)



Fig. 28.8. Ariel view of Qanats. (Source: www.visualphotos.com)

### Runoff vs. Flood Water Harvesting

- Water harvesting techniques which harvest runoff from roofs or ground surfaces fall under the term rainwater harvesting while all systems which collect discharges from watercourses are grouped under the term flood water harvesting.
- Runoff harvesting increases water availability for on-site vegetation while flood waters harvesting provide a valuable source of water to local and downstream water users and play an important role in replenishing floodplains, rivers, wetlands and groundwater.
- Runoff harvesting reduces water flow velocity, as well as erosion rate and controls siltation problem while in flood water harvesting, floodwater enters into the fields through the inundation canals, carrying not only rich silt but also fish which can

swim through the canals into the lakes and tanks to feed on the larva of mosquitoes.