

4.1 Introduction

Sheet metal work is very useful trade in engineering work and for our day-to-day needs. Many articles (household and engineering) whose production of other methods will be uneconomical and complicated are made from metal sheets. It is necessary to understand the construction and working of hand tools, sheet metal working machines and basic principles of different operations, to attain proficiency in the trade. For successful working in the trade, we must have a good knowledge or projective geometry, development of surfaces and properties of different metals.

4.2 Principle of sheet metal working

Sheet metal working is generally associated with press machines and press working. Press working is a chipless manufacturing process by which various components are produced from sheet metal. The thickness of metal varies from 0.1 mm to 10 mm. Press machine consists of a frame which supports a ram and bed and a mechanism for operating the ram.

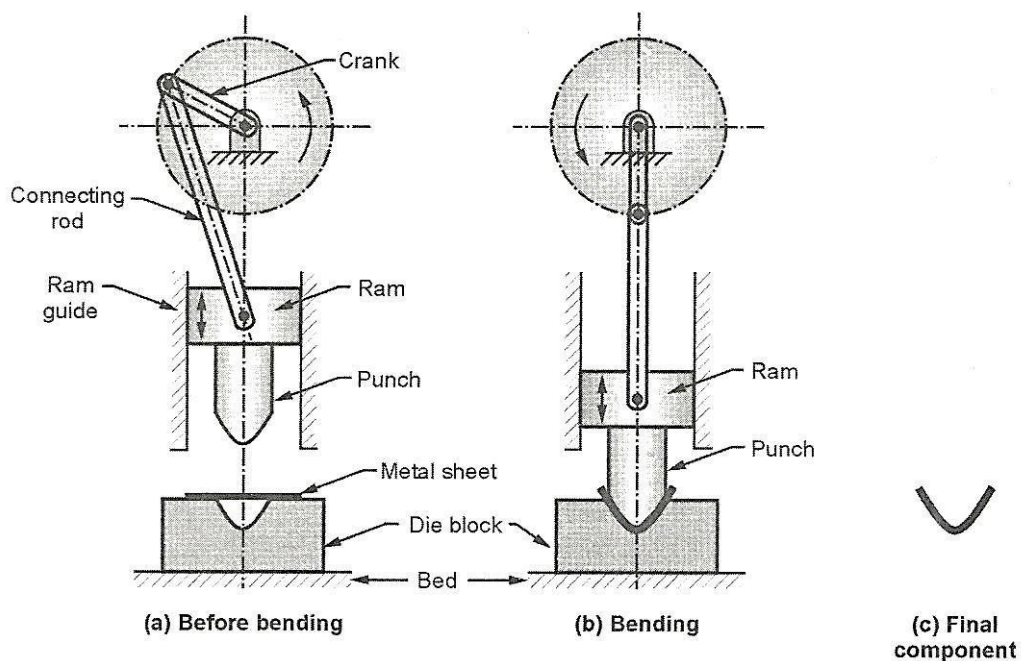

Fig. 4.1 : Sheet metal working

The ram is equipped with punch whereas die block is attached to the bed. The punch and die block assembly is called as die or die-set. Die block is a stationary part which contains die cavity and punch is a moving part which enters in the die cavity. During the operation, metal sheet is kept on the die block and punch moves downward. The punch forces the metal sheet into the die cavity, hence metal sheet will form the shape of the die cavity. There is always some clearance between the punch and die block. On the press machine, various operation can be performed and all the operations are done at the room temperature.

4.2.1 Advantages, disadvantages and Application of Sheet Metal Working:

Advantages

- Sheet metal working is associated with press machine, on which number of operations can be performed.
- Metal sheets of less thickness can be formed into various shapes.
- The components produced by sheet metal working are of low cost.
- Production rate of press machine is very high.
- The process does not require skilled labour.

Disadvantages

- Sheet metal working is only used for mass production.
- The cost of die is very high.
- Initial cost of press machine is also high.
- Metals of thickness more than 10 mm are difficult to form.
- The operation produces more noise and vibrations.

Applications

- The components produced by sheet metal working are as follows:
- Press parts are widely used in automobile (bikes, cars, trucks, buses, etc.) industry. Vehicle parts like doors, roofs, fuel tanks, front guards, etc. can be produced.
- Aircraft industry, radio and telephone industry, electrical parts, etc.

4.3 Metals used in sheet metal working

There are different types of metals used in sheet metal work in the form of sheets and plates. The specifications of metal sheets are given in terms of their gauge numbers, length and width. Gauge number represents a thickness of metal sheets. The higher the gauge number, the smaller the thickness. Some of the important sheet metals are as follows:

1. Black iron

Black iron or uncoated sheet carries no artificial coating on its surface, but is cheaper than other types of metal sheets. Components made from this type of metal are pans, tanks, cabinets, almirahs, stove, pipes, etc.

2. Galvanised iron

It is soft iron sheet carries zinc coating on its surface which make the surface good looking and rust resistant. Components made from this type of metal are storage tanks, buckets, heating ducts, furnaces, gutters, pans, trunks, etc.

3. Aluminium sheets

Due to low strength of aluminium sheets they are not used in their pure form, hence suitable amount of silicon manganese, copper and iron are added. It offers high resistance to corrosion and abrasion. They are used in the manufacture of aeroplane bodies, kitchenware and cabinets, doors, windows and building work, electrical appliances, etc.

4. Copper sheets

Copper sheets are costlier but offers good resistance to corrosion and relatively good in appearance. They are reddish in colour, highly ductile and malleable. They are used in applications like radiators of automobiles, heating appliance, gutters, hoods and components in chemical plants.

5. Stainless steel

Stainless steel offers high resistance to corrosion and exhibits a bright surface. It is used in the manufacture of food containing equipments, dairy equipments, food processing plant, chemical plant, etc.

6. Tin plates

Tin plates are used for those iron sheets which are coated with pure tin. Tin plates are used for making good containers, containers for cooking oils and ghee, cans, etc.

4.4 Sheet-metal characteristics

After a blank is cut from a larger sheet, it is formed into various shapes. Basically, all sheet forming process employ various dies and tooling to stretch and bend the sheet.

Before we consider these processes, however, certain characteristics of sheet metals must be reviewed, because of their important effects on the overall operation.

Characteristics metals important in sheet forming

Characteristic	Importance
Anisotropy (Planar)	Exhibits different behaviour in different planar directions present in cold-rolled sheets because of preferred orientation or mechanical fibering; causes earing in drawing; can be reduced or eliminated by an nearling but at lowered strength.
Elongation	Determines the capability of the sheet metal to stretch without necking and failure; high strain-hardening exponent (n) and strain-rate sensitivity exponent (m) desirable.
Grain size	Determines surface roughness or stretched sheet metal; the coarser the grain, the rougher the appearance (orange peel); also affects material strength.
Springback	Caused by elastic recovery of the plastically deformed sheet after unloading causes distortion of part and loss of dimensional accuracy; can be controlled by techniques such as overbending and bottoming of the punch.
Residual stresses	Caused by nonuniform recovery of the plastically deformed sheet after unloading causes distortion when sectioned and can lead to stress – corrosion cracking; reduced or eliminated by stress relieving.
Wrinkling	Caused by compressive stresses in the plane of the sheet; can be objectionable or can be useful in imparting stiffness to parts; can be controlled by proper tool and die design.
Surface condition of sheet	Depends on rolling practice; important in sheet forming as it can cause learning and poor surface quality.
Quality of sheared edges	Depends on process used; edges can be rough, not square, and contain cracks, residual stresses, and a work-hardened layer, which are all detrimental to the formability of the sheet; quality can be improved by control of clearance, tool and die design, fine blanking, shaving, and lubrication.
Yield-point elongation	Observed with mild-steel sheets; also called Lueder's bands and stretcher strains causes flamelike depressions on the sheet surfaces; can be eliminated by temper rolling, but sheet must be formed within a certain time after rolling.

4.5 Types of Sheet Metal Working

Press operations may be grouped into two categories i.e. *cutting operations and forming operations*. In cutting operations, the sheet metal is stressed beyond its ultimate strength whereas, in forming operations the stresses are below the ultimate strength of the metal.

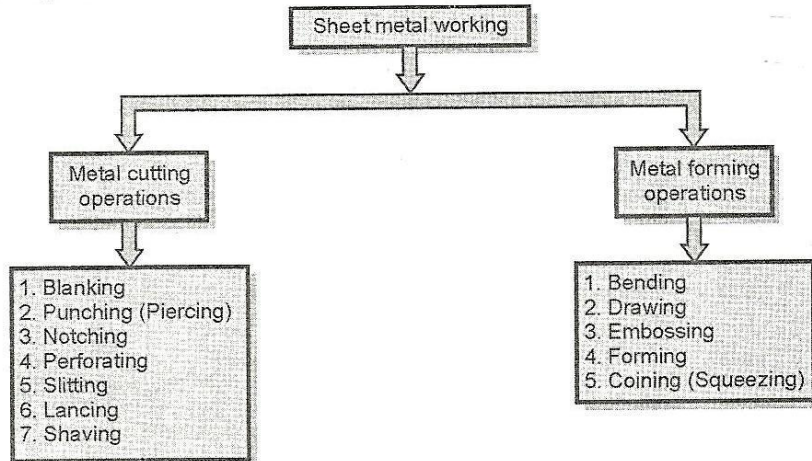

Fig. 4.2 : Types of sheet metal working

4.5.1 Metal Cutting Operations

In sheet metal cutting operations, the metal gets sheared hence these operations are also called as shearing operations. In these operations, the metal sheet is stressed beyond its ultimate strength. Metal cutting operations include following operations:

- | | | |
|----------------|------------------------|-------------|
| 1. Blanking | 2. Punching (Piercing) | 3. Notching |
| 4. Perforating | 5. Slitting | 6. Lancing |
| 7. Shaving | 8. Shearing | 9. Nibbling |

1. Blanking

Blanking is the cutting operation of a flat metal sheet and the article punched out is known as blank. Blank is the required product of the operation and the metal left behind is considered as a waste.

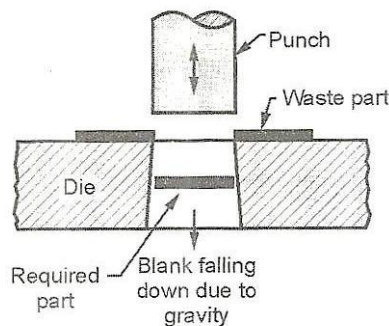

Fig. 4.3 : Blanking

2. Punching (Piercing)

It is the cutting operation with the help of which holes of various shapes are produced in the sheet metal. It is similar to blanking; only the main difference is that, the hole is the required product and the material punched out to form a hole is considered as a waste.

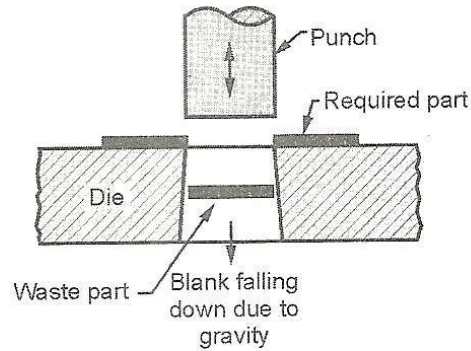

Fig. 4.4 : Punching (Piercing)

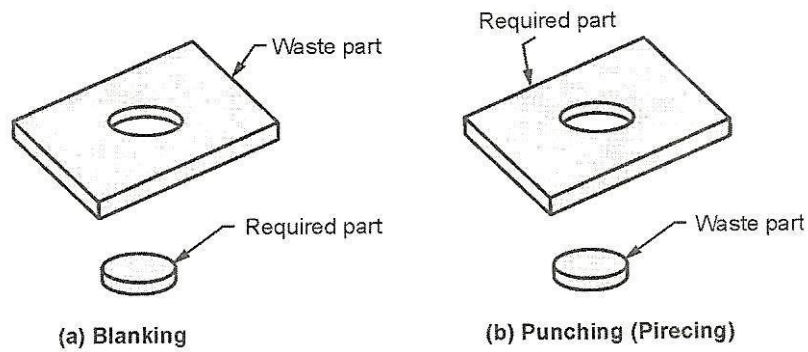

Fig. 4.5 : Blanking and punching (piercing)

3. Notching

It is similar to blanking operation, but in this full surface of punch does not cut the metal. In this operation, metal pieces are cut from the edges of a sheet.

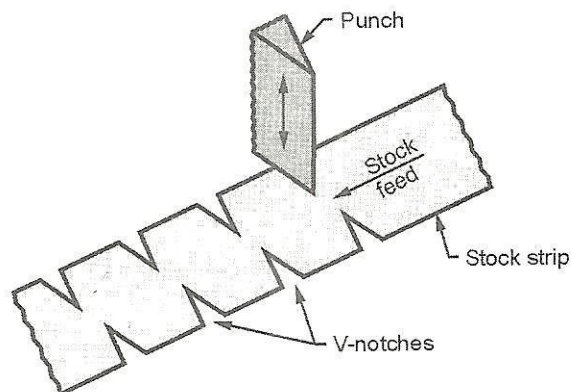

Fig. 4.6 : Notching

4. Perforating

It is similar to piercing but the difference is that, to produce holes the punch is not of round shape. In this process, multiple holes which are very small and close together are cut in the sheet metal.

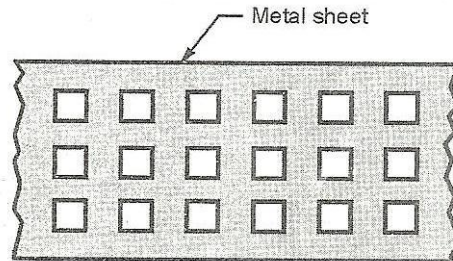

Fig. 4.7 : Perforating

5. Slitting

It is the operation of making an unfinished cut through a limited length only.

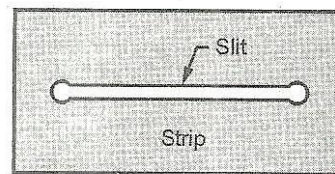

Fig. 4.8 : Slitting

6. Lancing

In this operation, there is a cutting of sheet metal through a small length and bending this small cut portion downwards.

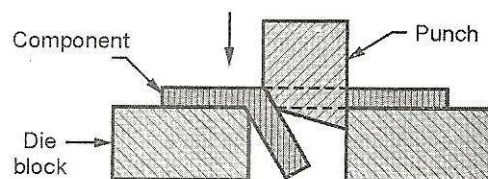

Fig. 4.9 : Lancing

7. Shaving

This operation is used for cutting unwanted excess material from the periphery of a previously formed workpiece. In this process very small amount of material is removed.

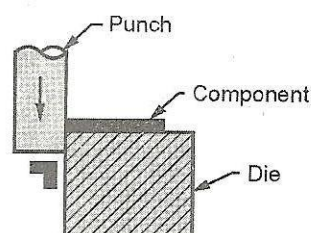

Fig. 4.10 : Shaving

8. Shearing

It is a process of cutting a straight line across a strip, sheet or bar. Shearing process has three important stages:

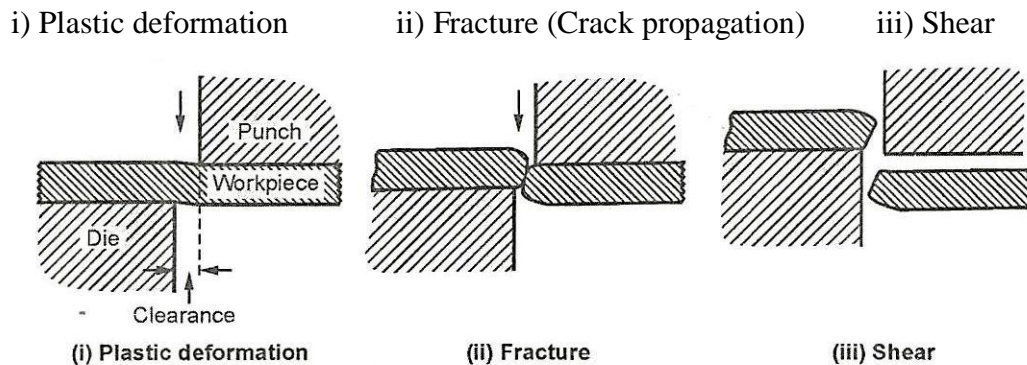

Fig. 4.11 : Steps in shearing process

When the metal is placed between upper and lower blades of the shear and pressure is applied, plastic deformation of metal takes place. As the pressure is continued, the fracture or crack start at the cutting edge of the blade. As the blade descends further, the small fractures meet and the metal is then sheared. Shearing is performed either by using hand or by using machines also.

9. Nibbling

This operation is generally substituted for blanking. It is designed for cutting out flat parts from sheet metal. The flat parts range from simple to complex contours. It is used only for small quantities of components.

4.5.2 Metal forming operations

In metal forming operations, the sheet metal is stressed below the ultimate strength of the metal. In these operations, no material is removed hence there is no wastage. Metal forming operations include following operations:

1. Bending
2. Drawing
3. Embossing
4. Forming
5. Coining (Squeezing)

1. Bending

It is a metal forming operation in which the straight metal sheet is transformed into a curved form. In bending operations, the sheet metal is subjected to both tensile and compressive stresses. During the operation, plastic deformation of material takes place beyond its elastic limit but below its ultimate strength.

The bending methods which are commonly used are as follows:

- a) U-bending
- b) V-bending
- c) Angle bending
- d) Curling
- e) Roll bending
- f) Bending in a 4-slide machine

g) Edge bending

a) U-bending

Figure shows U-bending operation which is also called as channel bending. In this operation, the die cavity is in the form U, due to which component forms the shape of U.

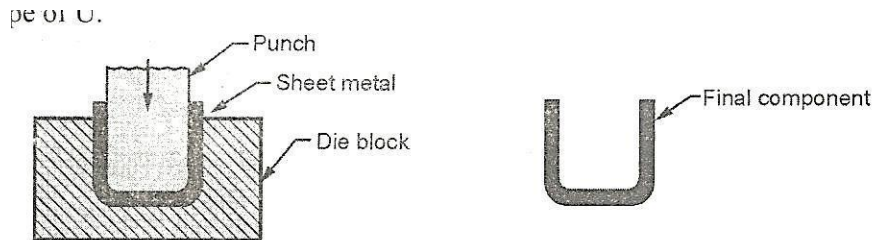

Fig. 4.12 : U-bending

b) V-bending

Figure shows V-bending operation in which wedge shape punch is used. The angle of V may be acute, 90° obtuse.

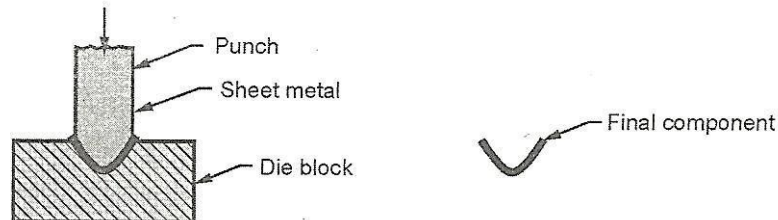

Fig. 4.13 : V-bending

c) Angle bending

In this operation, there is a bending of a sheet metal at a sharp angle.

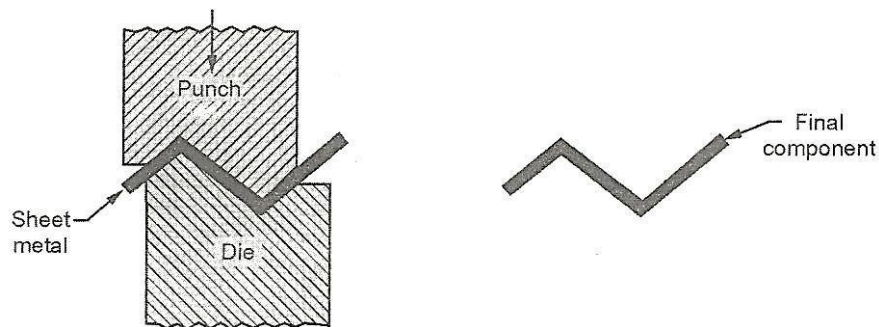

Fig. 4.14 : Angle bending

d) Curling

In this operation, the edge of a sheet metal is curled around. The punch and die both are made to contain the cavity for cutting partially. After the operation, punch moves up and workpiece is ejected out with the help of plunger as shown in figure. This process is used in the manufacturing of drums, pots, vessels, pans, etc.

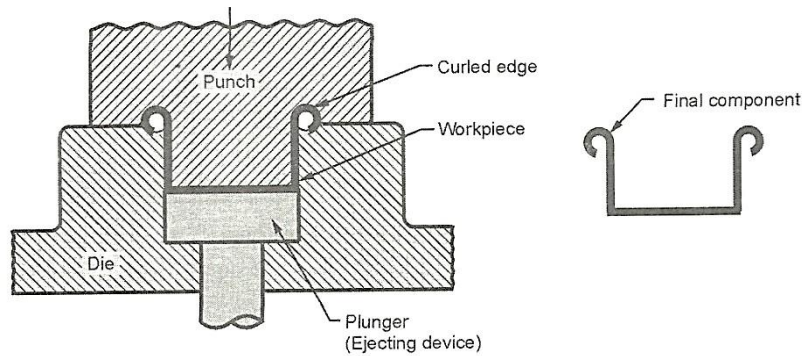

Fig. 4.15 : Curling

e) Roll bending

It is an operation in which generally large sheet metal parts are formed into curved sections with the help of rolls. When the sheet passes between the rolls, the rolls are brought towards each other to a configuration that achieves the required radius of curvature on the workpiece. It is used for fabrication of large storage tanks, pressure vessels, etc. Also used to bend metal plates, tubes, structural shapes etc.

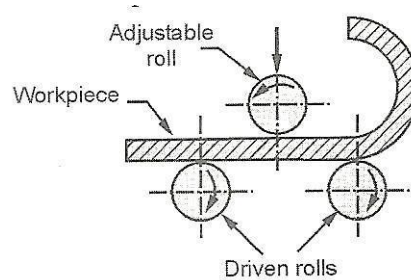

Fig. 4.16 : Roll bending

f) Bending in a 4-slide machine

This type of machine is used for bending of relatively short pieces. These type of machines are available in different designs. The lateral movements of the dies are controlled with the vertical die movement of form the part of desired shapes.

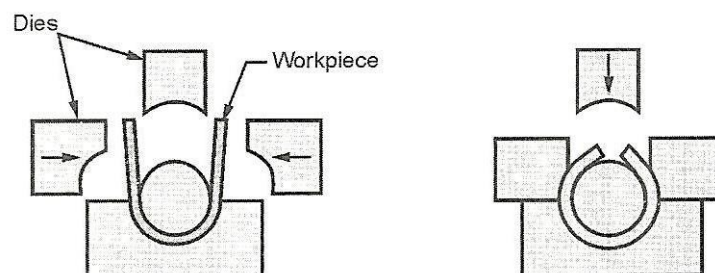

Fig. 4.17 : Bending in a 4-slide machine

g) Edge bending

It involves cantilever loading of sheet metal. In this method a pressure pad is used to hold the base of the workpiece against the die whereas the punch forces the workpiece to yield and bend over the edge of the die. The edge bending operation is limited to bends of 90° or less. The dies used for edge bending is called as wiping dies. They can also be designed for

bend angles greater than 90° . Due to pressure pad, wiping dies are more complicated and costly than the V-dies. These dies are used for high production work.

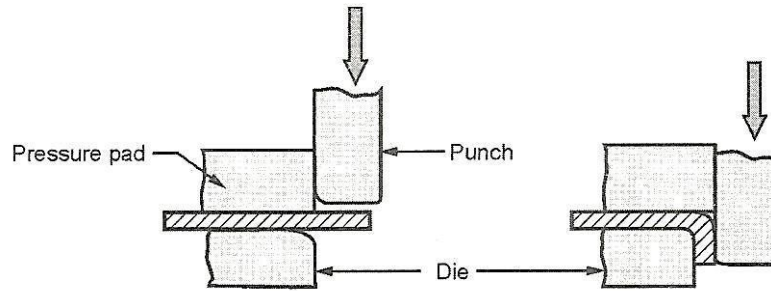

Fig. 4.18 : Edge bending

2. Drawing

In this operation, punch forces a sheet metal blank to flow plastically into the clearance between the punch and die. Finally, the blank takes a shape of cup.

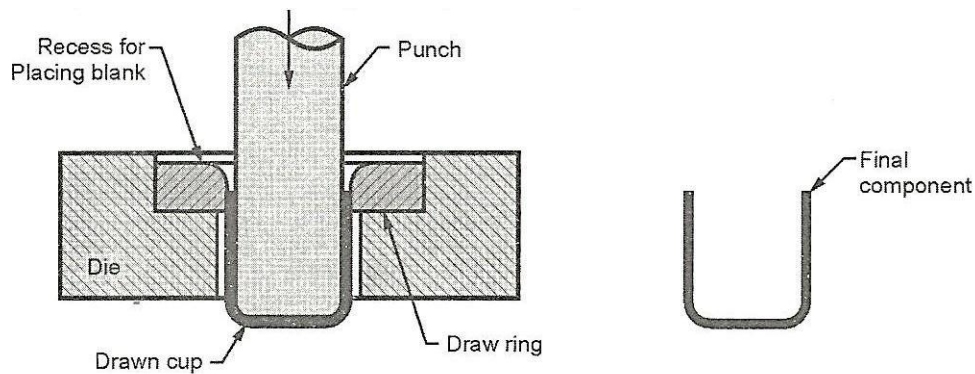

Fig. 4.19 : Drawing

3. Embossing

With the help of this operation, specific shapes or figures are produced on the sheet metal. It is used for decorative purposes or giving details like names, trademarks, specification, etc. on the sheet metal.

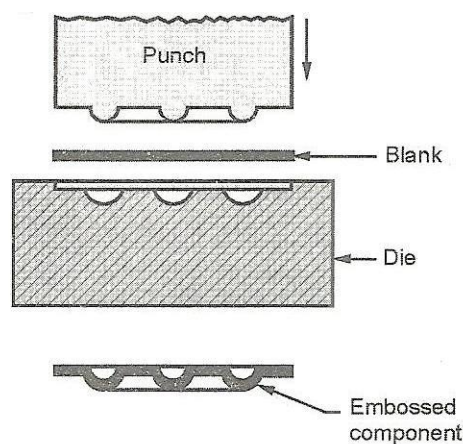

Fig. 4.20 : Embossing

4. Forming

In forming operation, sheet metal is stressed beyond its yield point so that it takes a permanent set and retains the new shape. In this process, the shape of punch and die surface is

directly reproduced without any metal flow. This operation is used in the manufacturing of door panels, steel furniture, air-craft bodies, etc.

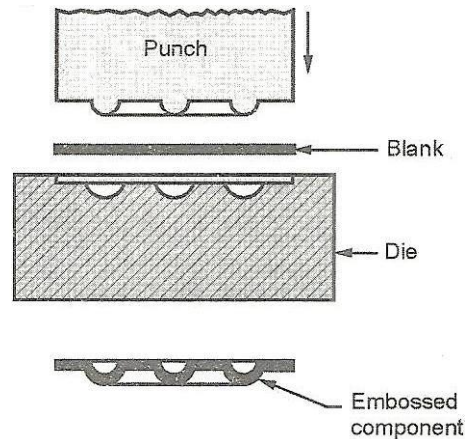

Fig. 4.20 : Embossing

5. Coining (Squeezing)

In coining operation, the metal having good plasticity and of proper size is place within the punch and die and a tremendous pressure is applied on the blank from both ends.

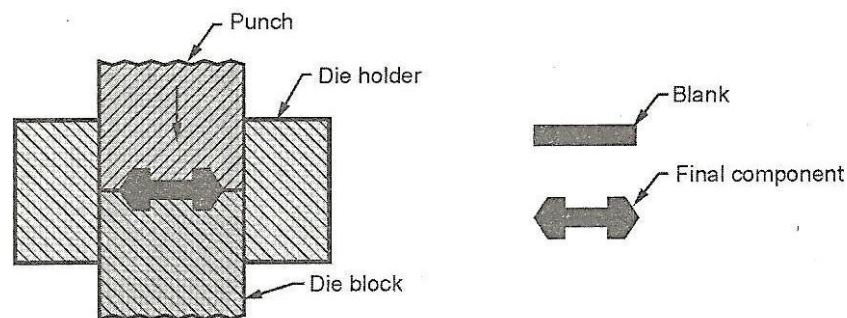

Fig. 4.22 : Coining

Under severe compressive loads, the metals flows in the cold state and fills up the cavity of the punch and die. This operation is used in the manufacturing of coins, medals, ornamental parts, etc.

4.6 Bending Operations

Bending in sheet-metal work is defined as the straining of the metal around a straight axis, as in figure 4.23.

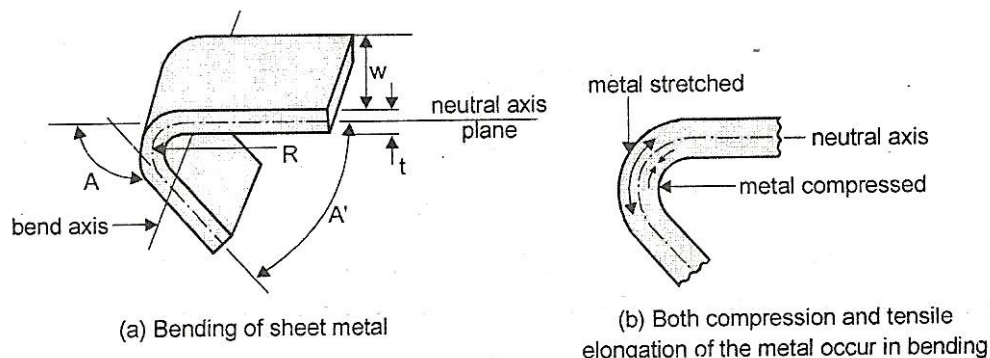

Figure 4.23. Bending Operations

During the bending operation, the metal on the inside of the neutral plane is compressed, while the metal on the outside of the neutral plane is stretched.

These strain conditions can be seen in figure. The metal is plastically deformed so that the bend takes a permanent set upon removal of the stresses that caused it. Bending produces little or no change in the thickness of the sheet metal.

4.6.1 V-bending and Edge bending

Bending operations are performed using punch and die tooling. The two common bending methods and associated tooling are V-bending, performed with a V-die, and edge bending, performed with a wiping die. These methods are illustrated in figure 4.24.

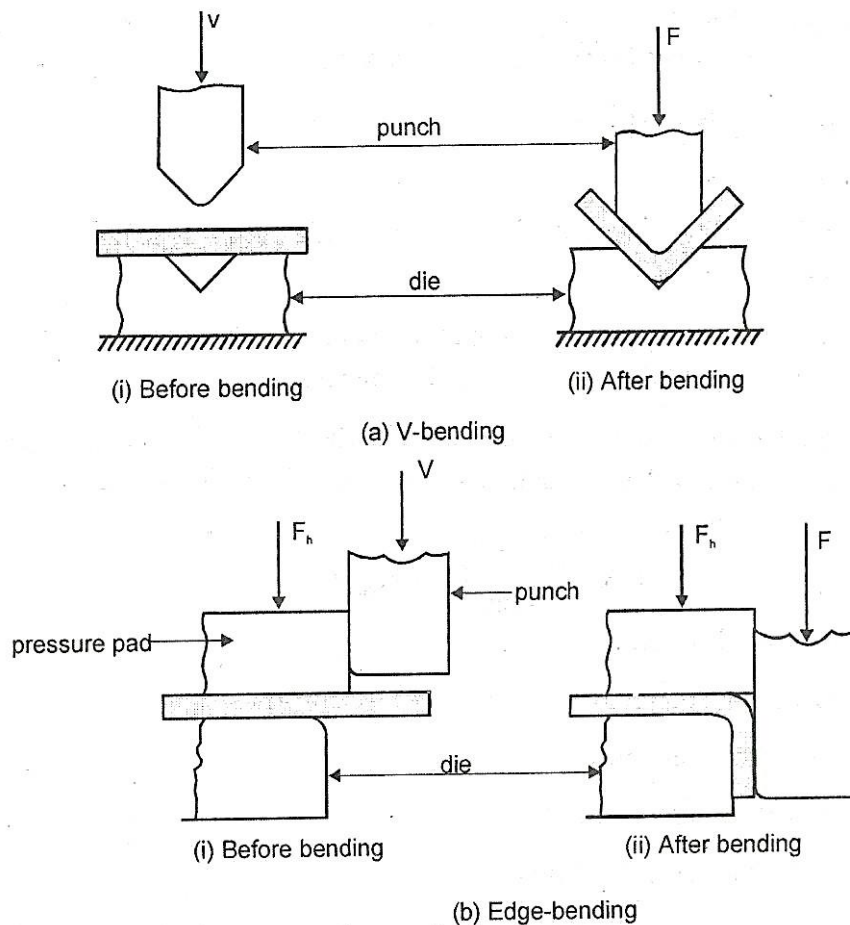

$V = \text{Motion}$, $F = \text{Applied bending force}$, $F_h = \text{Holding force}$

Figure 4.24. Two Common Bending Methods

In V-bending, the sheet metal is bent between a V-shaped punch and die. Included angles ranging from very obtuse to very acute can be made with V-dies.

V-bending is generally used for low-production operation. It is often performed on a press brake and the associated V-dies are relatively simple and inexpensive.

Edge bending involves cantilever loading of the sheet metal. A pressure pad is used to apply a holding force F_h to hold the base of the part against the die, while the punch forces the part to yield and bend over the edge of the die.

In the setup shown in figure 4.24, edge bending is limited to bends of 90° or less. More complicated wiping dies can be designed for bend angles greater than 90° .

Because of the pressure pad, wiping dies are more complicated and costly than V-dies and are generally used for high production work.

4.6.2 Important Factors of Bending

Bend Allowance

If the bend radius is small relative to stock thickness, the metal tends to stretch during bending. It is important to be able to estimate the amount of stretching that occurs, if any, so that the final part length will match the specified dimension. The problem is to determine the length of the neutral axis before bending to account for stretching of the final bent section. This length is called the bend allowance, and it can be estimated as follows:

$$BA = \frac{\pi R A}{180} + k t$$

Where BA-Bend allowance, in (mm)

A- Bend angle (degrees)

R-bend radius in (mm)

t-Stock thickness, in.(mm)

k – factor to estimate stretching

The values of k predict that stretching occurs only if bend radius is small relative to sheet thickness.

Springback

When the bending pressure is removed at the end of the deformation operation, elastic energy remains in the bent part, causing it to recover partially toward its original shape. This elastic recovery is called springback, defined as the increase in included angle of the bent part relative to the included angle of the forming tool after the tool is removed. This is illustrated in figure 4.25 and is expressed as

$$SB = \alpha - \beta$$

Where SB- Spring back

α - Included angle of the sheet-metal part (degrees)

β - Included angle of the bending tool (degrees)

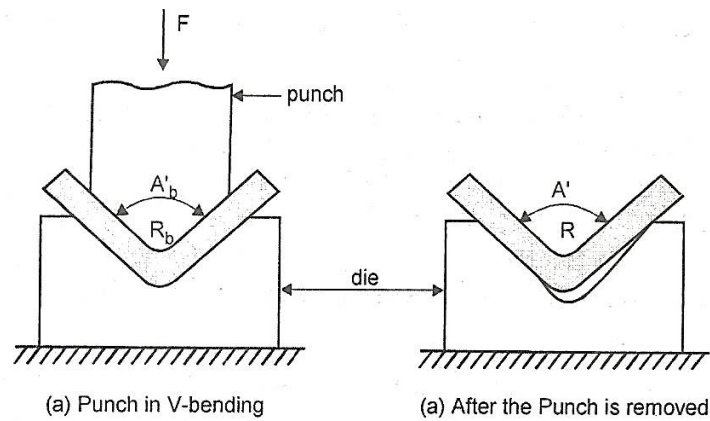

Figure 4.25 Springback Effect in V Bending

Bending force

The force required to perform bending depends on the geometry of the punch and die and the strength, thickness, and width of the sheet metal.

The maximum bending force can be estimated by means of the following equation, based on bending of a simple beam:

where F - Bending force, lb (N)

TS - Tensile strength of the sheet metal, MPa

ω - Width of part in the direction of the bend axis, in mm

t - Stock thickness, in mm

D - Die opening dimension for V-bending

K_{bf} - 1.33 for V bending, and for edge bending, $K_{bf}=0.33$.

4.7 Drawing operations

Drawing is a sheet-metal forming operation used to make cup-shaped, box-shaped, or other more complex-curved, hollow-shaped parts.

It is performed by placing a sheet-metal blank over a die cavity and then pushing the metal into the opening with a punch, as in figure 4.26.

The blank must usually be held down flat against the die by a blankholder. Common parts made by drawing include beverage cans, ammunition shells, sinks, cooking pots, and automobile body panels.

4.7.1 Mechanics of drawing

Drawing of a cup-shaped part is the basic drawing operation, with dimensions and parameters as pictured in figure 4.26.

Let us examine the parameters of the operation and the mechanics of how it performed. A blank of diameter D_b is drawn into a die by means of a punch of diameter D_p .

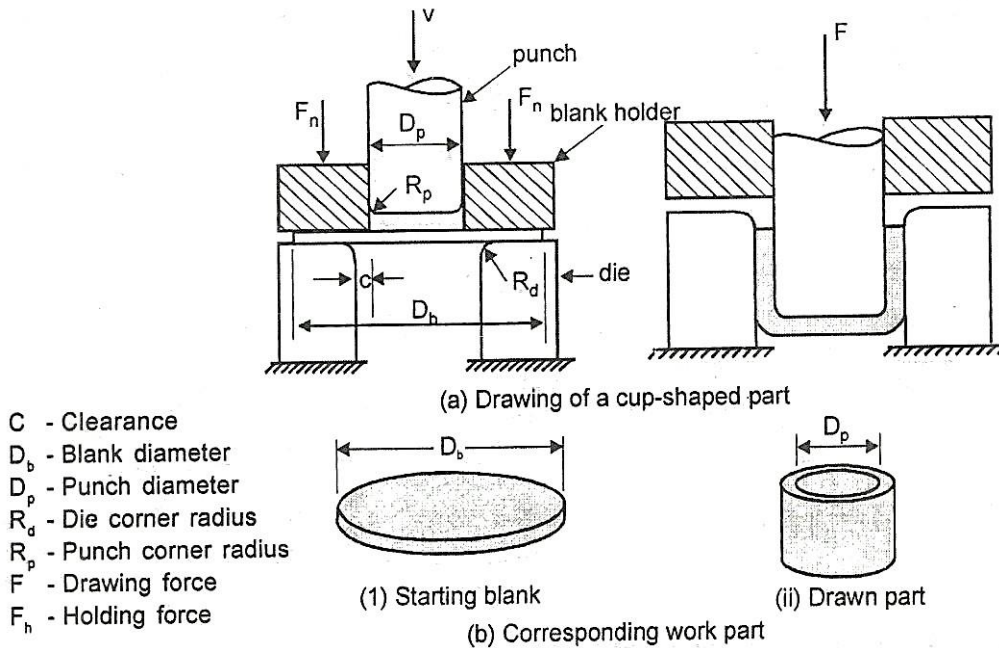

Figure 4.26. Drawing Operations

The punch and die must have corner radii, given by R_p and R_d . If the punch and die were to have sharp corners (R_p and $R_d=0$), a hole punching operation (and not a very good one) would be accomplished rather a drawing operation. The sides of the punch and die are separated by a clearance c .

This clearance in drawing is about 10% greater than the stock thickness:

$$C=1.1t$$

The punch applies a downward force F to accomplish the deformation of the metal, and a downward holding force F_h is applied by the blankholder, as shown in the sketch.

4.7.2 Stages in the deep drawing operation

As the punch proceeds downward its final bottom position, the work experiences a complex sequence of stresses and strains as it is gradually formed into the shape defined by the punch and die cavity.

The stages in the deformation process are illustrated in figure 4.27. As the punch first begins to push into the work, the metal is subjected to a bending operation.

The sheet is simply bent over the corner of the punch and the corner of the die, as in figure 4.27. The outside perimeter of the blank moves in towards the center in this first stage, but only slightly.

As the punch moves further down, a straightening action occurs in the metal that was previously bent over the die radius, as in the figure 4.27 (iii).

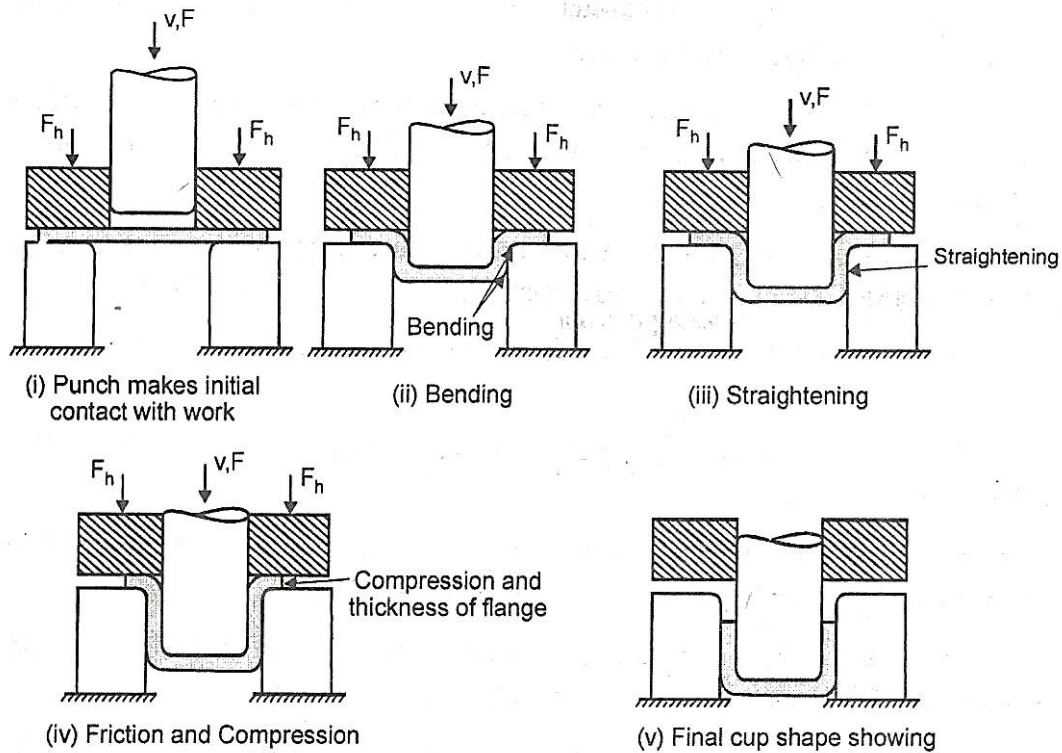

Figure 4.27 Stages in Deformation of the work in Deep Drawing

The metal at the bottom of the cup, as well as along the punch radius, has been moved downward with the punch, but the metal that was bent over the die radius must now be straightened in order to be pulled into the clearance to form the wall of the cylinder.

At the same time, more metal must be added to replace that which is now being used in the cylinder wall. This new metal comes from the outside edge of the blank.

The metal in the outer portions of the blank is pulled or drawn toward the die opening to resupply the previously bent and straightened metal now forming the cylinder wall.

It is this type of metal flow through a constricted space from which the drawing process gets its name.

During this stage of the process, friction and compression play important roles in the flange of the blank.

For the material in the flange to move toward the die opening friction between the sheet metal and the surfaces of the blankholder and the die must be overcome.

Initially, static friction is involved until the metal starts to move; then, after metal flow begins. Dynamic friction governs the process.

The magnitude of the holding force applied by the blankholder, as well as the friction conditions at the two interfaces, are determining factors in the success of this aspect of the drawing operation.

Lubricants or drawing compounds are generally used to reduce friction forces. In addition to friction, compression is also occurring in the outer edge of the blank.

As the metal in this portion of the blank is drawn toward the center, the outer perimeter becomes smaller.

Because the volume of metal remains constant, the metal is squeezed and becomes thicker as the perimeter is reduced.

This often results in wrinkling of the remaining flange of the blank, especially when thin sheet metal is drawn or when the blankholder force is too low.

It is a condition that cannot be corrected once it has occurred. The friction and compression effects are illustrated in figure 4.27.

The holding force applied by the blankholder is now seen to be a critical factor in deep drawing. If it is too small, wrinkling occurs.

If it is too large, it prevents the metal from flowing properly toward the die cavity, resulting in stretching and possible tearing of the sheet metal.

Determining the proper holding force involves a delicate balance between these opposing factors.

Progressive downward motion of the punch results in a continuation of the metal flow caused by drawing and compressions, as described previously.

In addition, some thinning of the cylinder wall occurs, as shown in figure 4.27. The force being applied by the punch is opposed by the metal in the form of deformation and friction in the operation.

A portion of the deformation involves stretching and thinning of the metal as it is pulled over the edge of the die opening.

4.7.3 Defects in drawing

A number of defects can occur in a drawn product, some of which we have already alluded to. Following is a list of common defects, with sketches in figure 4.28

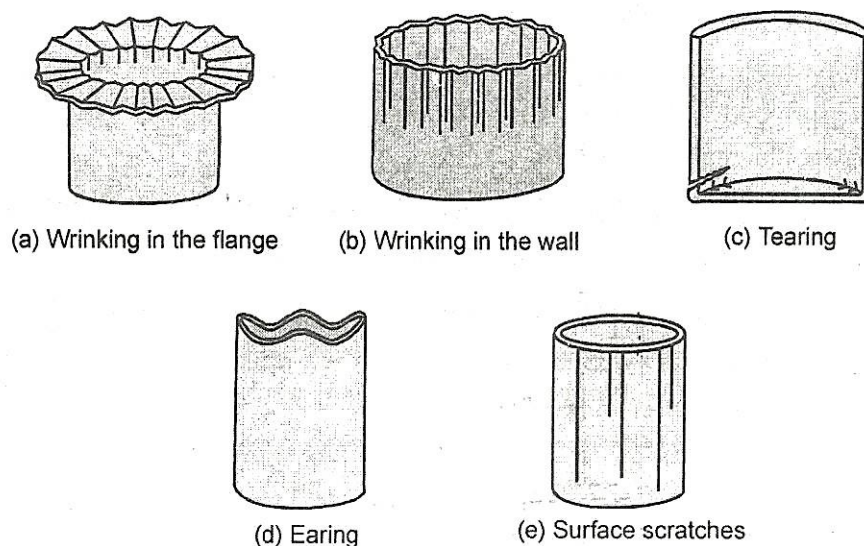

Figure 4.28 Defects in Drawing

- a) **Wrinkling in the flange:** wrinkling in a drawn part consists of a series of ridges that form radially in the undrawn flange of the workpart due to compressive buckling.
- b) **Wrinkling in the wall:** If and when the flange is drawn into the cup, these ridges appear in the vertical wall.
- c) **Tearing:** Tearing is an open crack in the vertical wall, usually near the base of the drawn cup, due to high tensile stresses that cause thinning and failure of the metal at this location. This type of failure can also occur as the metal is pulled over a sharp die corner.
- d) **Earing:** This is the formation of irregularities (called ears) in the upper edge of a deep drawn cup, caused by anisotropy in the sheet metal. If the material is perfectly isotropic, ears do not form.
- e) **Surface scratches:** Surface scratches can occur on the drawn part if the if the punch and die are not smooth or if lubrication is insufficient.

4.8 Stretch Forming Operations

This method is used for producing large accurately contoured sheets. It has been developed in Second World War period itself.

Stretching is the process of stressing the work blank beyond its elastic limit by moving a form block towards the blank or sheet metal. The form block has projections of exact size required on the blank which is in the form of depressions on the same blank. Stretching is mainly done for straightening a part to obtain a straight axis and uniform cross-section. During stretching the blank, the spring back occurs after completing the stretching process.

Spring back is defined as the movement of the metal to resume its original position causing a decrease in bend angle after the applied force is withdrawn. So, this spring back has to be considered to obtain exact shape and size of the blank after the stretching process. Spring back always depends on material type, thickness of the blank, hardness of the blank and bend radius. Generally large bend radius produces greater spring back on the blank. But, this spring back can be avoided by

- i. Over stretching using V-type form blocks, and
- ii. By coining the metal slightly at the corners of the blank to remove elastic stresses called corner setting.

4.8.1 Methods of Stretch Forming

The stretch forming process can be done in two methods such as

1. Form – block method
2. Mating – die method

1. Form-block method

In this method, the two ends of the blank or sheet metal is tightly held by an adjustable grippers are fixed but adjustable. Then, the form block is moved towards the blank to make the required shape. In this case, the form-block is operated by hydraulic cylinder. When the form-block moves towards the blank, the hydraulic fluid inside cylinder gets compressed and delivered through the outlet valve. The movement of the form always depends the hydraulic fluid pressure inside cylinder. The fluid is entered the cylinder when the form-block moves away from the blank after completing stretching process. In a single stretching process, we can get no need of stages in stretching. Force exerted on the piston is calculated as

Where, d = Diameter of the piston
 P = Hydraulic fluid pressure

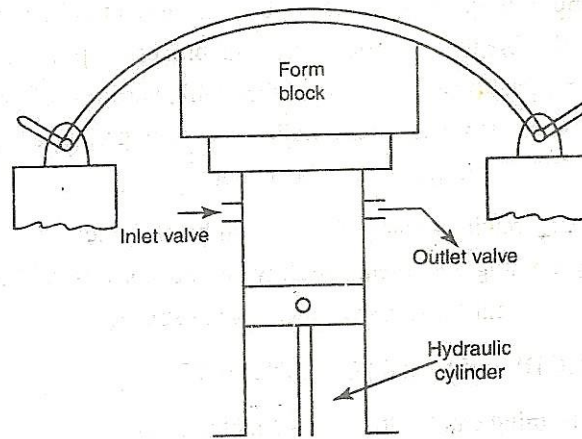

Figure 4.29 Form-block method

Stretching the blank can also be done by fixing the form block stationary and moving the grippers towards the form-block. It is performed by holding the blank ends in movable grippers.

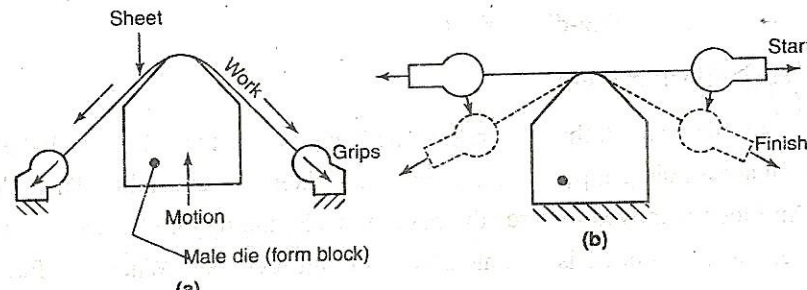

Figure 4.30 Stretch Forming

2. Mating-die method

In this method, the blank is held in movable grippers. The blank is placed between the lower and upper die. The lower die is kept stationary and the upper die is movable one which is operated by hydraulic or pneumatic cylinders.

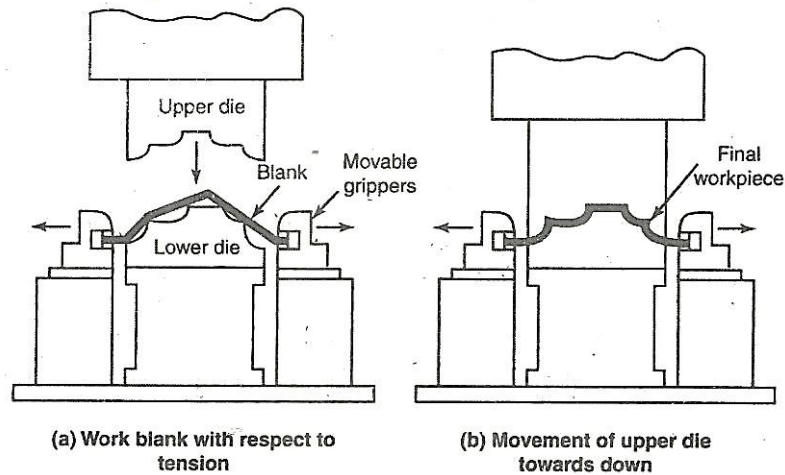

Figure 4.31 Stretch draw forming with Mating-dies

First, the movable grippers are moved towards the lower die on which only elastic deformation takes place. Next, the upper die is moved towards the blank. When the upper die touches the blank, only elastic change takes place. Due to continuous stretching of the blank by the upper die, plastic flow of sheet metal takes place between lower and upper dies. When the upper die edges reach the top surface of the blank, the stretching process is completed.

Materials for die and form blocks

Wood, Masonite, zinc alloys and cast iron.

Advantages

Blanks can be stretched in a single operation.

1. No need of any heat-treatments before and after the stretching process.
2. Spring back is reduced or eliminated when compared to other forming methods.
3. Direct bending is not introduced.
4. Plastic deformation is due to pure tension only.
5. Tooling costs are low.
6. This method is more suitable for low volume production.

Disadvantages

1. Blank thickness should be uniform throughout the length. (Thin sections are to be overstretched).
2. Sudden changes in contour surfaces cannot be stretched.
3. Maintenance cost of hydraulic cylinders is high.
4. The process requires high quality form-blocks.

Limitations

1. Uneven thickness of blank cannot be stretched.
2. Stretching of blank to the required shape of contour is limited.

Applications

1. Production of aircraft wing and fuselage parts.
2. Production of contoured panels for truck trailer and bus bodies in automobile industry.

4.9 Formability of sheet metals

Sheet-metal formability is of great technological and economic interest. It is normally defined as the ability of the sheet metal to undergo the desired shape change without such failure as necking or tearing, sheet metals may (depending on part geometry) undergo two basic modes of deformation: a) stretching and b) drawing.

There are important distinctions between these two modes, and different parameters are involved in determining formability under these different conditions.

4.9.1 Formability test methods

The two important test methods are carried out while processing the sheet metals.

They are:

1. Cupping test
2. Forming-Limit Diagrams (FLD)

1. Cupping tests

Because sheet-forming is basically a process of stretching the material, the earliest, test developed to predict formability were cupping tests.

The sheet-metal specimen is clamped between two circular flat dies, and a steel ball or round punch is pushed hydraulically into the sheet metal until a crack begins to appear on the stretched specimen.

The greater the value is of the punch depth d , the greater is the formability of the sheet.

Although such test are easy to perform (and are approximate indicators of formability), they do not simulate the exact conditions of actual sheet-forming operations.

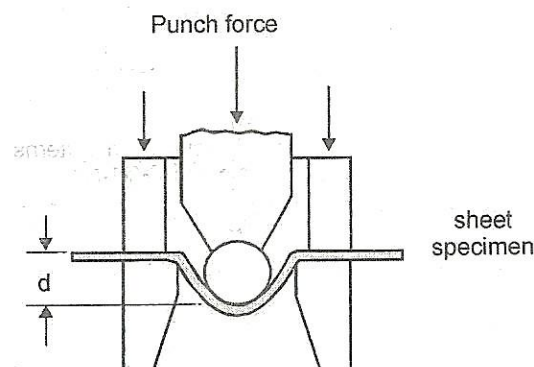

Figure 4.32 Cupping tests

2. Forming – Limit Diagrams (FLD)

An important development in testing the formability of sheet metals is the forming limit diagram (FLD).

The sheet is marked with a grid pattern of circles, typically 2.5 to 5 mm (0.1 to 0.2 in) in diameter, using electrochemical or photoprinting techniques.

The blank is then stretched over a punch, and the deformation of the circles is observed and measured in regions where failure has occurred. For improved accuracy of measurement, the circles are made as small as practicable.

In order to develop unequal stretching, as in actual sheet-forming operations, the specimens are cut to varying widths (figure 4.33)

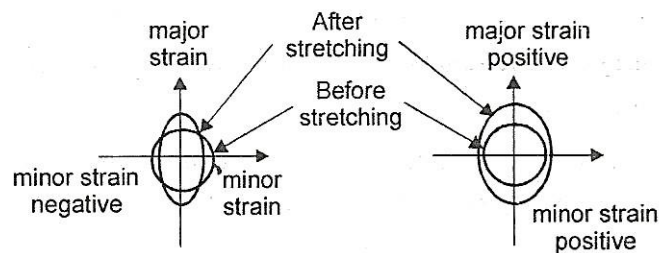

(a) Strains in deformed circular grid patterns

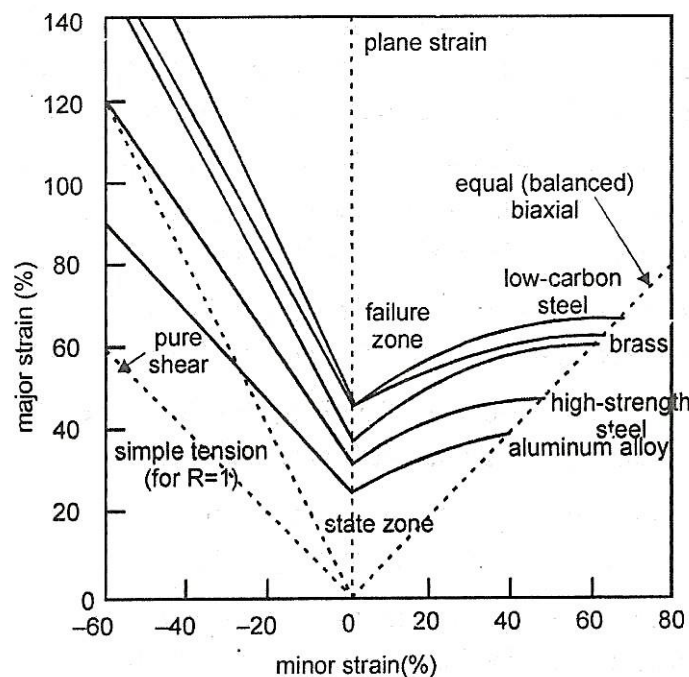

(b) Forming-limit diagrams (FLD) for various sheet metals

Figure 4.33 Forming – Limit Diagrams

Note that a square specimen (farthest right in the figure) produces equal biaxial stretching (such as that achieved in blowing up a spherical balloon), whereas a narrow specimen (farthest left in the figure) approaches a state of uniaxial stretching (simple tension).

After a series of such tests is performed on a particular sheet metal at different widths, a forming-limit diagram showing the boundaries between failure and safe regions is constructed (figure).

In order to develop the forming-limit diagram, the major and minor engineering strains, as measured from the deformation of the original circles, are obtained as follows.

Note in figure that the original circle has deformed into an ellipse. The major axis of the ellipse represents the major direction and magnitude of stretching.

The major strain is the engineering strain in this direction, and is always positive, because of sheet-metal stretching. The minor axis of the ellipse represents the magnitude of the stretching or shrinking in the transverse direction of the sheet metal.

Note that the minor strain can be either negative or positive. If, for example, a circle is placed in the center of a tensile-test specimen and then stretched, the specimen becomes narrower as it is stretched (Poisson effect), and the minor strain is negative.

On the other hand, if we place a circle on a spherical rubber balloon and inflate it, the minor and major strains are both positive and equal in magnitude.

By comparing the surface areas of the original circle and the deformed circle on the formed sheet, we can also determine whether the thickness of the sheet has changed.

The data obtained from different locations in each of the samples shown in figure are plotted in the form shown in figure.

The curves represent the boundaries between failure and safe zones. Thus, if a circle underwent major and minor strains of plus and minus 40%, respectively, there would be no tear in that region of the specimen.

On the other hand, if the major and minor strains in an aluminum – alloy specimen were plus 80% and minus 40%, respectively, there would be a tear in that region of the specimen.

An example of a formed sheet-metal part with a grid pattern is shown in figure. Note the tear, and note the deformation of the circular patterns in the vicinity of the tear region.

Figure 4.33 shows that different materials have different forming-limit diagrams and that the higher the curve, the better the formability of the material.

The effect of sheet-metal thickness on forming-limit diagrams is to raise the curves in figure.

The thicker the sheet, the higher its formability curve, and the more formable it is. On the other hand, in actual forming operations, a thick blank may not bend as easily around small radii without cracking.

4.10 Special forming processes

Generally, forming process is done by pressing the form tool over the blank to obtain the required shape. The form tool is actuated by hydraulic cylinder using hydraulic fluid. In the case of mating die method, sheet metal is placed over the lower die and its ends are fixed on movable grippers. Then, the upper die is moved towards the blank. If the female or upper die is actuated by any other means except hydraulic fluid contained in the cylinder in forming process called special forming process. Example: Explosive forming metal spinning, hydro forming etc.

Types of special forming process

There are various types special forming process as follows:

1. Hydroforming
2. Rubber pad forming
3. Metal spinning
4. Explosive forming
5. Magnetic pulse forming
6. Peen forming
7. Super plastic forming

4.10.1 Hydro forming process

Hydroforming is a drawing process. It is forming process is carried out in two ways, they are

1. Hydro mechanical forming, and
2. Electro hydraulic forming

1. Hydro Mechanical Forming

In this type of forming process, the punch is connected to the lower die called male die. The required shape of inner configuration is made on the punch. A rubber diaphragm or seal is used for making perfect sealing between male and female die. This seal is placed across the bottom of the pressure forming chamber. The pressure-forming chamber is filled with a hydraulic fluid. Then, the blank is correctly positioned over the male die or lower die. Now, the pressure forming chamber called dome is lowered over the blank in such a way that the dome is made to just contact with the blank.

After this, hydraulic pressure is applied over the blank. Simultaneously, the punch is pushed into the blank. The pressure applied by the hydraulic fluid is increased continuously. Due to this, the blank metal flows around the punch to form the required shape. The inverted shape of the punch is made on the blank. (Convex shape of the punch is made as concave shape on the blank and vice versa). After forming the required shape, the chamber pressure is released. Then the chamber is raised from the blank. Finally, the blank is stripped out from the

punch. In this case, the required shape of the blank is obtained only by drawing rather than by bending. And also, the blank metal is displaced due to plastic flow instead of stretching.

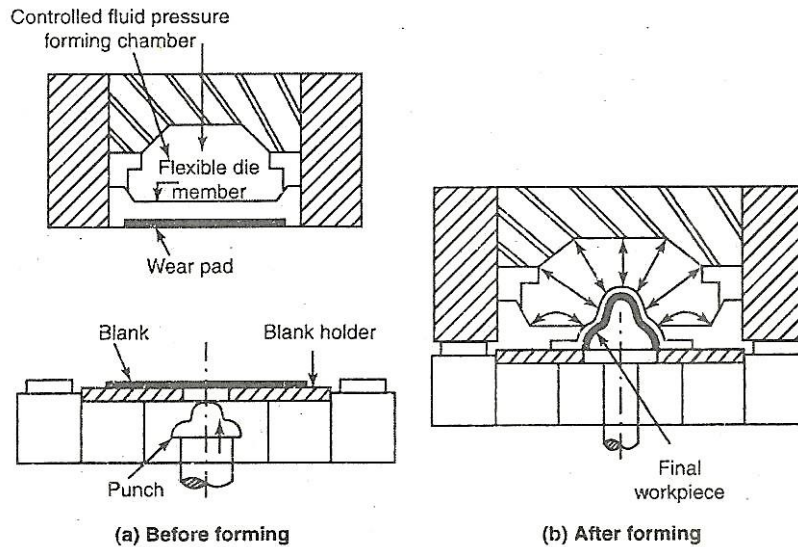

Figure 4.34 Hydro Mechanical Forming

Advantages:

1. Thinning of metal, spot stresses and spring back are drastically reduced or completely eliminated.
2. It is used for mass production because work performed per operation is high.
3. Tool changing can be done rapidly.
4. Complicated contours can also be made.
5. Sharp corners are also possible.
6. All type of sheet metals can be handled.
7. Due to uniform flow metal between punch and pressure chamber, the mechanical and physical properties are improved.
8. Tolerance of 0.005mm/mm are possible practically.

2. Electrohydraulic Forming Process

The working principle of metal forming process is same as that of hydro mechanical forming process. But, the applied pressure over the blank differs because the pressure inside the pressure forming chamber is produced by electrical means. The arrangement of this electro hydraulic forming system is shown figure 4.35.

When the supply is given to electrical circuit, a high energy is discharged through a bank of capacitor to the hydraulic fluid contained the chamber. The discharged energy in the chamber is in the form of shock waves and pressure. This mechanical energy is used for metal forming operations in the same manner as mentioned in hydro mechanical forming operations.

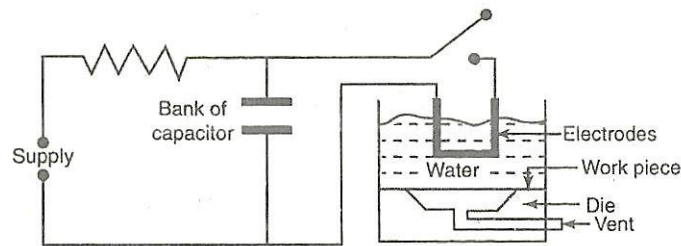

Figure 4.35 Electrohydraulic Forming Process

Advantages:

1. The pressure inside the chamber is high due to combined shock wave and fluid pressure.
2. Time required per operation is low when compared to hydro mechanical forming operations.

Disadvantages

1. Energy losses occur between electrical components to hydraulic fluid.
2. Due to shock waves drag force and lift force is created and finally it results stagnation pressure in the fluid.
3. Stagnation properties refer to the properties at zero velocity.

4.10.2 Explosive forming

Explosive forming makes use of the pressure wave generated by an explosion in a fluid, for applying the pressure against the wall of the die. The explosives are used in the form of rod, sheet, granules, stick, liquid, etc. According to the placement of the explosive (charge) the operations are divided in two categories:

1. Standoff operation
2. Contact operation

1. Standoff operation:

In this type of operation, the charge is located some distance away from the workpiece and energy is transmitted through a fluid medium like water. Operating pressure for the workpiece is between several thousand to several hundred thousand kg/cm^2 . Process time or working time is measured in milliseconds, whereas metal removal velocity is measured in m/sec . This method is used to form and size the parts.

2. Contact operation:

In this type of operation, the explosive or charge is in direct contact with the workpiece and the explosive energy acts directly on the metal. By using this method, welding, hardening, compacting powdered metals and controlled cutting are performed.

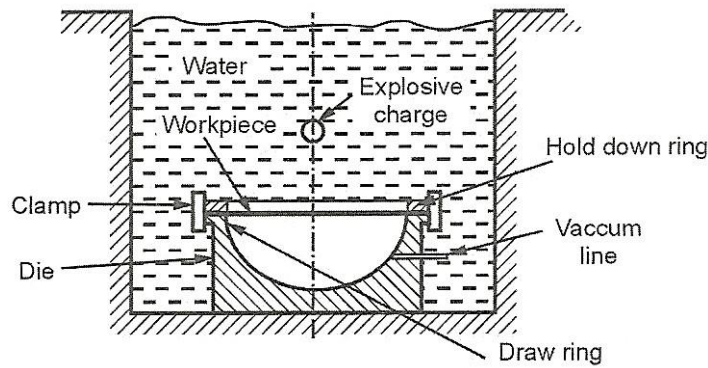

Figure 4.36 Explosive Forming Operation

Figure 4.36 shows the explosive forming for stand-off operation. In this method, the explosive charge is placed at some known distance from the workpiece. When the explosive is detonated, its energy is transmitted through a fluid medium (here water) to the workpiece held on a die. To avoid adiabatic compression and heating of the entrapped air, the space in the die behind the workpiece is generally evacuated. If vacuum is not created between the workpiece and die, then an air cushion would develop as the metal is being forced into the die. It also prevents the metal from seating in the die and assuming its shape. When the explosive detonates under water, it produces a shock wave and a bubble of hot gaseous detonation products. At any given distance from the explosive charge centre, the high intensity portion of the pressure pulse produced by the detonating explosive is represented by,

$$P = \frac{P_m}{1 + \frac{t}{\tau}}$$

Where, P = Pressure as a function of time

P_m = Peak pressure for that distance

t = Time arrival of pressure front at the blank surface

τ = Time constant characteristics of the charge weight,

Type of explosive and distance from the explosive

The time constant represent the time that it takes the pressure to fall upto 50% of its peak value and it defines the limit of the straight line portion of a time curve. Explosive forming process is used for the following operations:

Blanking, Embossing, Coining, Drawing, Sizing, Expanding, Cutting, etc.

Advantages of explosive forming:

- For forming purpose, large and expensive presses are not required.
- Component is mostly formed in one cycle only.
- Only one die (male or female) is required which reduces the tooling cost.
- By using this method, ultimate and yield strength of sheet metal are improved.
- Large size components can be formed easily.

- Low capital investment is required.

Disadvantages of explosive forming:

- High skilled operators are required.
- Some complex components cannot be formed in one cycle only.
- Due to noisy operation, this process is located form the main city which increases the transportation and handling costs.
- Suitable only for low quantity production.
- Applications of explosive forming
- This process is mainly used in aerospace industries.

4.10.2.1 Explosives

Explosives are substances that undergo rapid chemical reaction during which heat and large quantities of gaseous products are produced. Explosives can be solid (TNT-trinitro toluene), liquid (Nitroglycerine), or gaseous (oxygen and acetylene mixtures). Explosives are divided into two classes; Low Explosives in which the ammunition burns rapidly rather than exploding, hence pressure build up is not large, and High Explosives which have a high rate of reaction with a large pressure build up. Low explosives are generally used as propellants in guns and in rockets for the propelling of missiles.

4.10.2.2 Die materials

Different materials are used for the manufacture of dies for explosive working, for instance high strength tool steels, plastics, concrete. Relatively low strength dies are used for short run times and for parts where close tolerances are not critical, while for longer runs higher strength die materials are required. Kirksite and plastic faced dies are employed for light forming operations; tool steels, cast steels, and ductile iron for medium requirements.

4.10.2.3 Transmission medium

Energy released by the explosive is transmitted through medium like air, water, oil, gelatin, liquid salts, etc. water is one of the best media for explosive forming since it is available readily, inexpensive and produces excellent results. Water is more suitable medium than air for producing high peak pressures to the workpiece.

4.10.3 Rubber Pad Forming

Rubber pad forming process is also known as **marform process**. It is a metal working process where sheet metal is pressed between a die and rubber block. Under pressure, the rubber and sheet metal are driven into the die and conform to its shape by forming the part.

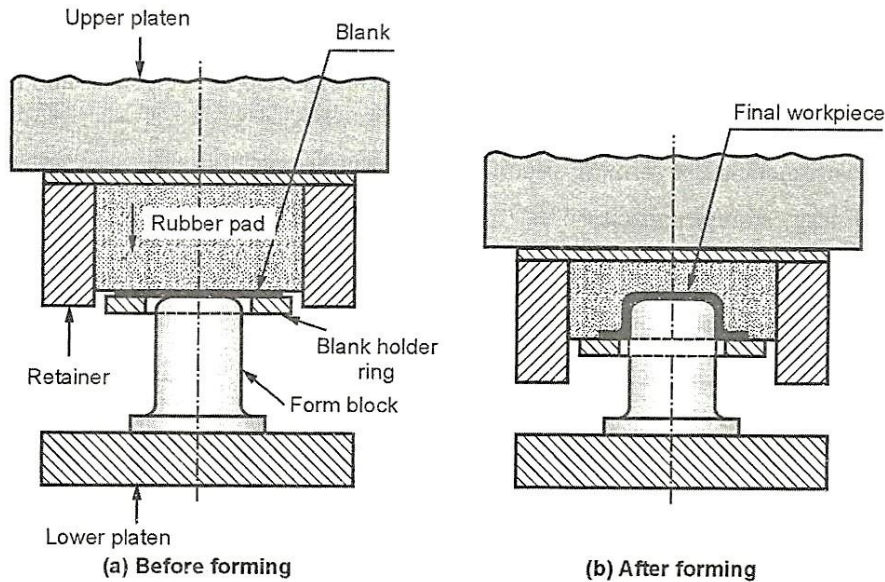

Figure 4.37 Rubber Pad Forming

This process is mostly used for bending and drawing operations. In this method, number of different form blocks (punches) is arranged at regular intervals along the pressing pad (rubber pad) Refer figure 4.37.

Initially the blank is placed on the form block and the stationary blank holder. The force is applied on the blank with the help of hydraulic cylinder through the ram and rubber pad. The pad is generally made of rubber or polyurethane. During forming, the upper platen is moved to just touch the top surface of the blank and after this, the force is applied and gradually increased by using rubber pad. Thus, the required shape is obtained (formed) on the sheet metal and the cycle is repeated. The retainers, placed both sides of rubber pad, are used to apply essential hydrostatic pressure on the blank and prevent sideward motion.

Advantages of rubber pad forming:

- ✓ Cost of tooling is less.
- ✓ The process is more flexible.
- ✓ Time required for tool setting is less.
- ✓ Lubricants are not required.
- ✓ Thinning of metal blank does not take place.
- ✓ Deep sheets can be produced.
- ✓ A formed components doesn't have any wrinkles.
- ✓ Process is more economical.

Disadvantages of rubber pad forming:

- There is difficulty in the forming of sharp corners.
- Rubber pad will wear out at faster rate.

Application of rubber pad forming

This process is used for producing flanged cylindrical and rectangular cups, spherical domes, shells with parallel or tapered walls. Also used for producing variety of unsymmetrical shapes.

4.10.4 Magnetic Pulse forming

By using this method, it is possible to apply a powerful uniform magnetic pulse on a metallic workpiece, to swage and expand tubular forms, also to coin, shear and form flat sheets.

A basic magnetic pulse forming circuit consists of

- Energy storage capacitor
- Switch
- Power supply
- Coil

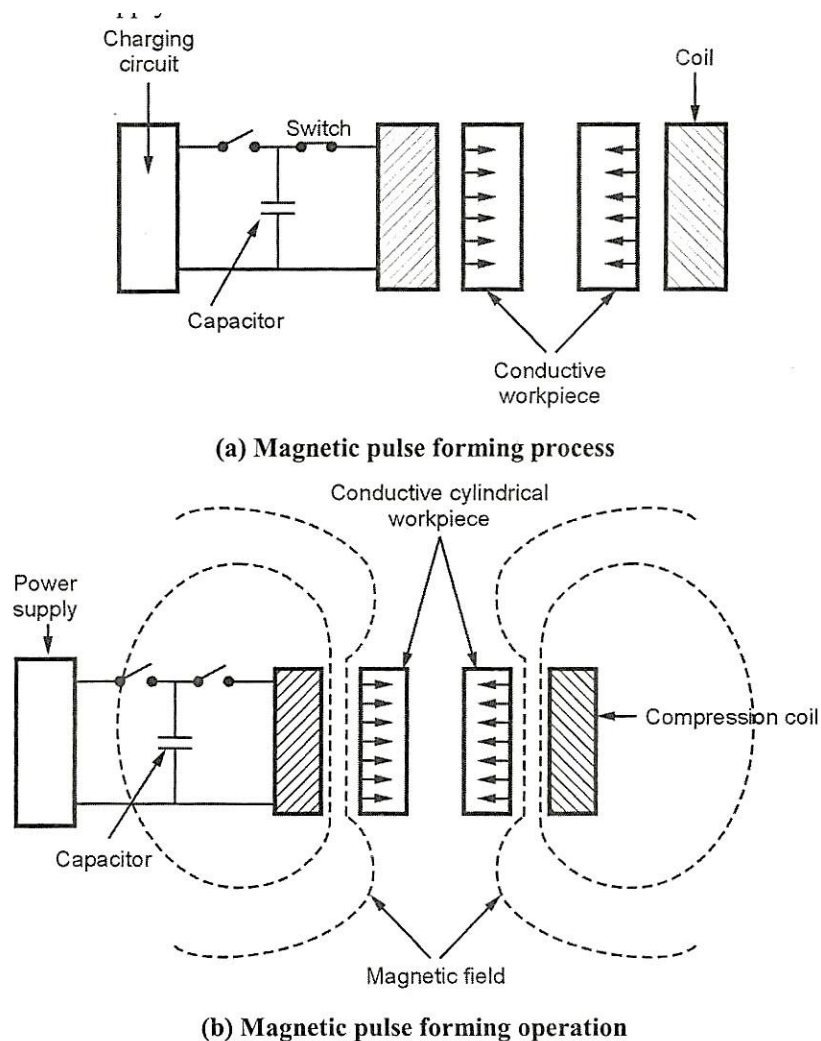

Figure 4.38 Magnetic Pulse forming

An insulated induction is either wrapped around or placed within the workpiece, depending on the requirement as shown in figure. The coil is shaped to produce the required shapes on the workpiece and power source is a capacitor bank. The capacitor can be charged slowly, generally in 3 to 6 sec. and discharged rapidly around 15 to 20 μ s, delivering a high current and power for a short time. When very high currents for a short time are passed through the coil, an intense magnetic field is developed which causes the workpiece to collapse, compress, shrink or expand as per the design and placement of the coil. Energy storage capacity and ability of the unit determines the size of the workpiece that can be formed.

Advantages of magnetic pulse forming:

- Highly conductive metals can be formed easily.
- The pressure is applied on the workpiece without any physical contact.
- As there is no friction, lubricants are not required.
- There are no tool marks on the workpiece.
- Machines can be designed for repetition rates.

Disadvantages of magnetic pulse forming

- Because of short duration of pressure pulse, deep drawing is not possible.
- Difficulty in the forming of unsymmetrical parts.
- Irregularities like slots, holes, grooves and difficult to form, because magnetic field is disrupted.

Applications of magnetic pulse forming

It is used for the attachment of rubber boots, as used in automotive ball joints. It is used to expand, compressor to form tubular shapes and also conical, ellipsoidal and flat workpiece. It is used in the forming of excellent conductors like aluminium, copper, brass, low carbon steel, etc. This method is also used for piercing shearing, cupping, embossing, sizing, etc.

4.10.5 Peen forming

Peen forming is also called as shot peening. Shot peening process consists of throwing a blast of metal shots on to the surface of a component. The blast may be thrown either by using air pressure or by a wheel rotating at high speed. This high velocity metal blast shot provides a sort of compression over the surface of a component. This increases the strength and hardness of the surface and also its fatigue resistance. Figure 4.39 shows shot peening action on a component.

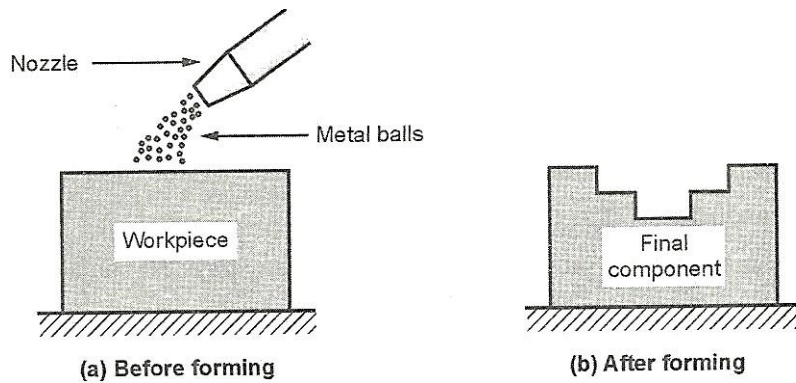

Figure 4.39 Peen Forming

Shot peening is also performed to prevent the cracking of workpiece in corrosive media and to improve the oil retaining properties of the processed surfaces. Generally, the shots are made of cast iron, steel, aluminium or glass. Cast iron or steel shot is used in peening steel workpiece whereas, aluminium or glass shot is used for non-ferrous alloys. The efficiency of the process mainly depends on angle between the path of the shot and the surface being peened. Another factor which affects the efficiency is the duration of peening which is generally 10 minutes. Shot peening is generally used for the manufacturing of coil springs, leaf springs, gear wheels and other complex parts.

4.10.6 Superplastic forming

Superplastic forming (SPF) is a metal working process used for forming sheet metal. It works upon the theory of superplasticity, which means that a material can elongate or stretch beyond 100% of its original size. Superplasticity is the ability of certain materials to undergo extreme elongation at the proper temperature and strain rate. Superplasticity of metals is defined by very high tensile elongations, ranging from two hundred to several thousand percent. The Superplastic process generally conducted at high temperature and under controlled strain rate which can give a ten-fold increase in elongation as compared to conventional room temperature processes.

Components are formed by applying gas pressures (generally argon) between one or more sheets and a die surface, causing the sheets to stretch and fill the die cavity. As the alloys of interest only exhibit Superplastic behaviour for certain temperature dependent range of strain rates, the evolution of pressures must be closely controlled during the process. Specific alloys of aluminum, stainless steel, and titanium are commercially available with the fine-grained microstructure and strain rate sensitivity of flow stress which is necessary for Superplastic deformation.

Process:

During the SPF process, the material is heated to the SPF temperature within a sealed die. For titanium this is around 900°C and for aluminium its between 450°C to 520°C. Inert gas

pressure is then applied, at a controlled rate forcing the material to take the shape of the die pattern. Refer figure 4.40.

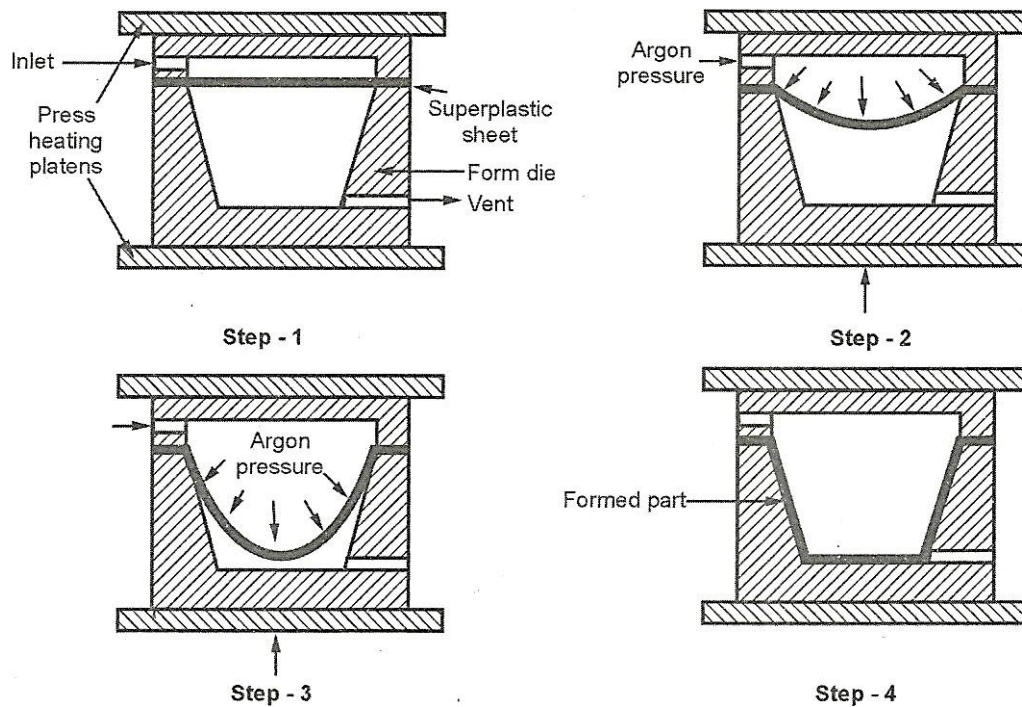

Figure 4.40 Superplastic forming

The flow stress of the material during deformation increases rapidly with increasing strain rate. Superplastic alloys can be stretched at higher temperatures by several times of their initial length without breaking. Typical aluminum alloy sheets can elongate 10-30% during forming. Forming must also be done at low strain rates on the order of 10^{-3} to 10^{-4} s⁻¹. There are several different types of super plasticity in terms of the microstructural mechanisms and deformation conditions. These are:

- Micrograin Superplasticity
- Transformation Superplasticity
- Internal stress Superplasticity

Some of the materials developed for super plastic forming are:

- Bismuth – tin (200% elongation)
- Zinc-aluminum
- Titanium (Ti-6Al-V)
- Aluminum (2004, 2419, 7474)
- Aluminum – lithium alloys (2090, 2091, 8090)

Advantages of Superplastic forming

- Superplastic forming technique offers the potential to reduce the weight and cost of large automotive structural components for advance vehicle applications.
- The main advantages of this process are:

- The major advantage of this process is that it can form large and complex components in one operation only.
- The process can be used to form complex components in shapes which are near to the final condition.
- The process eliminates unnecessary joints and rivets.
- After forming subsequent machining is not required.
- It minimizes the amount of scrap produced.
- It also does not suffer from springback or residual stresses.
- Less tooling cost.

Disadvantages of superplastic forming

- Its forming rate is slow.
- Cycle time may vary from two minutes to two hours, hence it is generally used for low volume production.
- Sometimes materials must not be superplastic at service temperatures.

Applications of superplastic forming

The process is increasingly being applied in the aerospace industry as a way of manufacturing very complex structures.

- In automotive body panels.
- In forming of aircraft frames.
- Diaphragm forming of plastics.
- Complex shape parts like window frames, sent structures, etc.

4.10.7 Metal spinning Process

The process of forming seamless metal parts from a circular sheet metal or from a tube length on a lathe is called as spinning process. Only symmetrical shapes can be produced from metal spinning process.

First, the circular blank is centered on a lathe which is placed against a form block. The form block is mounted on the head stock of the spinning lathe. The blank is tightly held between form block and tail stock spindle. The required contour surface is made on the form block. The pressure is applied by the roller type forming tool which is placed on the tool post of the spinning lathe.

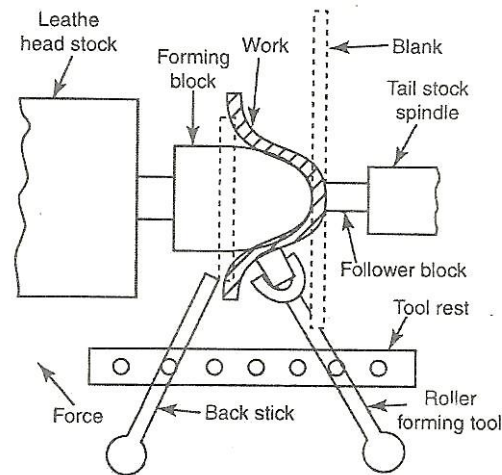

Fig.4.41. Spinning

The required shape is gradually formed by continuous application of pressure by the roller. During spinning process, some stretching and thinning of material take place. Metal spinning can be done both in cold and hot states. Heat generation due to friction between spinning tool or roller type forming and blank can also be used to retain the plastic state of sheet metal. Spinning speed varies with size, design, type of metal and thickness of sheet metal.

Aluminum, copper, brass and stainless steel can also be spun in spinning process. This process is mainly suitable for producing conical shape parts and suitable for low volume production. Components produced in this process do not require any trimming or beading operations. For producing more complex shapes, segmental chucks made from cast aluminum, magnesium alloys or hard wood reinforced with cold rolled steel sheets are used. The lubricants of grease, linseed oil and bees wax are used while using bead and tallow between form tool and blanks during spinning process.

Advantages

1. The parts not be drawn by drawing operations can be easily spun.
2. Heat generated due to friction is used to retain the sheet metal in the plastic state.
3. The process is more economical for low volume production.

Disadvantages

1. Thinning takes place during spinning process.
2. More complex shapes require segmental chucks. Finally, it leads to increase in cost.
3. Accuracy and quality of finished products mainly depend on the skill of the operator.

4.10.8 Micro Forming in Sheet Metal Processes

It is well known that the sheet metals thickness is between 0.4 and 6 mm but while micro-sheet forming usually handles the sheet metals of which the thickness is less than 0.3 mm. Therefore, it is called as thin strips or coils. The major sheet processes in micro sheet

forming are shearing, cutting, bending, unbending, stretching, compressing, stress relaxation etc.,

Similar to conventional sheet metal, the mechanical properties of the materials such as elasticity, plasticity, stress strain relations, strain rate, work hardening, temperature effect, anisotropy, grain size and residual stress involve in analysing the deformation of micro-forming products. the effects of grains sizes, orientations of micro-forming products. the effects of grains sizes, orientations and grain boundary properties are more significant in micro-sheet forming while considering the effects of overall stress-strain relationships, sheared-section qualities, spring back phenomenon, stress relaxation, etc.

Generally, the micro forming processes are used to make parts of the followings:

- Cellular Telephones
- IC Lead frames
- Electronics
- Healthcare
- Miniature Fasteners
- Hard Disc Driver
- National Security & Defense
- Automobiles
- Sensors

Sheet metal components are mainly used in various applications such as vehicles, aircraft, electronics products, medical implants and packaging for consuming goods, car panels, aircraft skins, cans for food and drinks and frames of: TV, computer screens, monitors and displays, etc.

Especially, micro-formed components are used in high precision applications such as electrical connectors and lead frames, micro-meshes for masks and optical devices, micro springs for micro switches, micro-cups for electron guns and micro-packaging, micro laminates for micro-motor and fluidic devices, micro gears for micro mechanical devices, casings for micro-device assembly, micro knives for surgery etc.,