

HYDRAULICS AND PNEUMATICS

Chapter -1

UNIT I FLUID POWER PRINCIPLES AND HYDRAULIC PUMPS

Introduction to Fluid power – Advantages and Applications – Fluid power systems – Types of fluids – Properties of fluids and selection

FLUID POWER: It may be defined as the technology that deals with the generation, control and transmission of power using pressurized fluids

TYPES OF FLUID SYSTEMS:

Fluid Transport systems: The objective of the fluid transport systems is to transport fluids from one place to another place to achieve some useful purpose

Fluid Power systems: The Fluid power system is primarily designed to perform work. That is these systems use pressurized fluids to produce some useful mechanical movements to accomplish the desired work.

Method of transmitting power:

Electrical power transmission

Mechanical power transmission

Fluid power transmission

Hydraulic power transmission

Pneumatic power transmission

ADVANTAGES OF FLUID POWER:

1. Easy and Accuracy to Control With the use of simple levers and push buttons, the fluid power system can facilitate easy starting, stopping, speeding up or slowing down and positioning forces that provide any desired power.
2. Multiplication of small forces to achieve greater forces for performing work

3. It easily provides infinite and step less variable speed control which is difficult to obtain from other drives.
4. Accuracy in controlling small or large forces with instant reversal is possible with hydraulic systems
5. Constant force is possible in fluid power system regardless of special motion requirements. Whether the work output moves a few millimeters or several meters per minute.
6. As the medium of power transmission is fluid, it is not subjected to any breakage of parts as in mechanical transmission.
7. The parts of hydraulic system are lubricated with the hydraulic liquid itself.
8. Overloads can easily controlled by using relief valves than is possible with overload devices on the other systems. Air equipments reduces the danger of fire and explosion hazard in industries such as painting and mining.
9. Because of the simplicity and compactness the cost is relatively low for the power transmitted.
10. No need of lubrication

DISADVANTAGES:

1. Leakage of oil or compressed air
2. Busting of oil lines, air tanks
3. More noise in operation

APPLICATIONS OF FLUID POWER:

1. **Agriculture:** Tractors and farm equipments like ploughs, mowers, chemical sprayers, fertilizer spreaders, haybalers
2. **Automation:** Automated transfer machines
3. **Aviation:** Fluid power equipments like landing wheels on aeroplane and helicopter, aircraft trolleys, aircraft engine testbeds.
4. **Building Industry:** For metering and mixing of concrete ingredients

from hopper.

5. **Construction Equipment:** Earthmoving equipments like excavators, bucket loaders, dozers, crawlers, post hole diggers and road graders.
6. **Defense :** Missile-launch systems and Navigation controls
7. **Entertainment:** Amusement park entertainment rides like roller coasters
8. **Fabrication Industry:** Hand tools like pneumatic drills, grinders, bores, riveting machines, nut runners
9. **Food and Beverage:** All types of food processing equipment, wrapping, bottling
10. **Foundry:** Full and semi automatic molding machines, tilting of furnaces, die casting machines
11. **Glass Industry:** Vacuum suction cups for handling
12. **Material Handling:** Jacks, Hoists, Cranes, Forklift, Conveyor system

HYDRAULIC SYSTEM:

An electric motor drives the hydraulic pump so that the fluid is pumped from the tank at the required pressure. The fluid circulated into the system should be clean to reduce the wear of the pump and cylinder; hence a filter is used immediate to the storage tank. Since the pump delivers constant volume of fluid for each revolution of the shaft the fluid pressure rises indefinitely until a pipe or pump itself fails. To avoid this some kind of pressure regulators is used to spill out the excess fluid back to the tank. Cylinder movement is controlled by a 3 position change over control valve. One side of the valve is connected to a pressurized fluid line and the fluid retrieval line and other side of the valve is connected to port A and port B of the cylinder. Since the hydraulic circuit is a closed one, the liquid transferred from the storage tank to one side of the piston, and the fluid at the other side of the piston is retrieved back to the tank.

Raise: To lift the weight, the pressurized fluid line has to be connected to port A and the retrieval line has to be connected to the port B, by moving the valve position to “raise”.

Lower: To bring down the weight, the pressurized fluid line has to be connected to port B and the retrieval fluid line has to be connected to port A, by moving the valve position to “lower”.

Off: The weight can be stopped at a particular position by moving the valve position to off. This disconnects the port A and port B from the pressurized line and the retrieval line which locks the fluid in the cylinder.

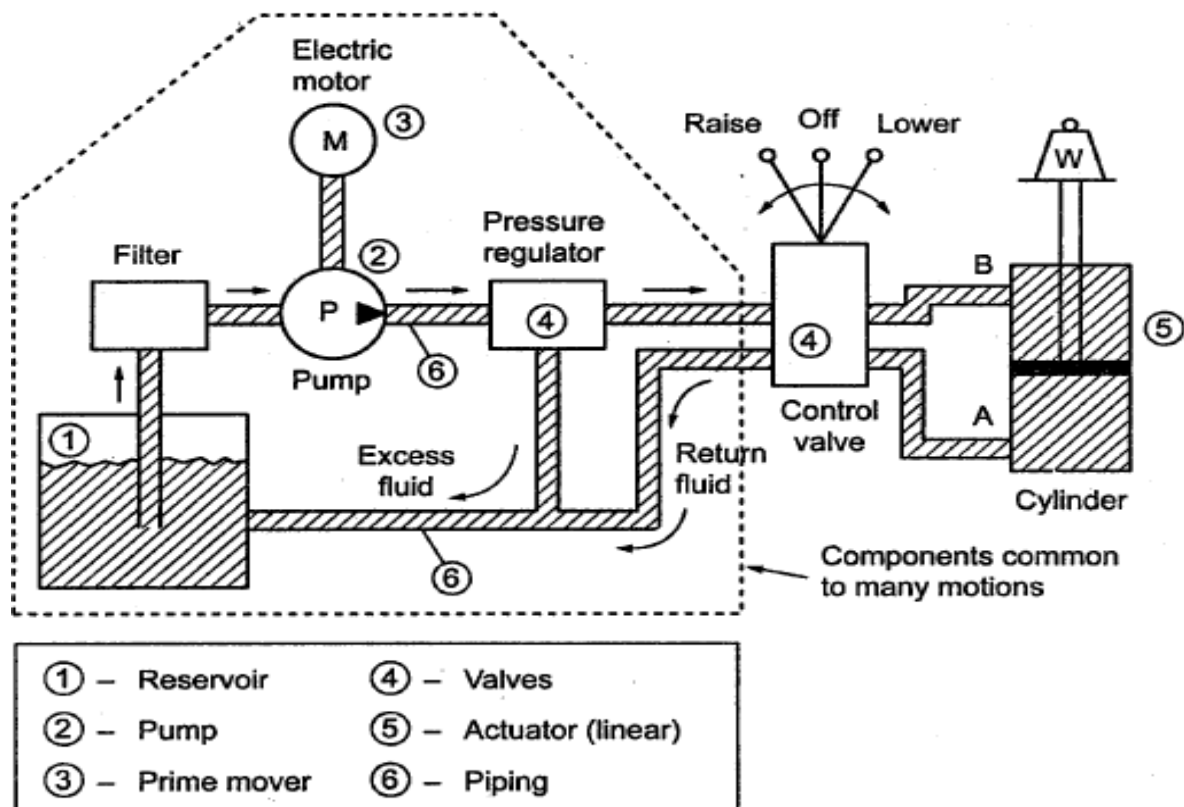

General arrangement of a hydraulic system

PNEUMATIC POWER SYSTEM:

Air is drawn from the atmosphere through the air filter and raised to the required pressure by an air compressor. Air contains significant amount of water vapour and also the air temperature is raised considerably by the compressor. So the air must be cooled before using it in the system, which results in condensation. The compressed air is stored in the reservoir which has water outlet at the bottom of the reservoir and a

pressure switch to control the pressure of the compressed air. Pressure switch stops the motor when the required pressure is attained and starts the motor when the pressure falls down the mark. The cylinder movement is controlled by the pneumatic valve. One side of the pneumatic valve is connected to the compressed air line and silencers for the exhaust air and the other side of the valve is connected to port A and port B of the cylinder.

Raise: To lift the weight, the compressed air line has to be connected to port A and the port B is connected to the exhaust air line by moving the valve position to raise.

Lower: To bring down the weight, the compressed air line is connected to port B and the port A is connected to exhaust air line by moving the valve position to lower.

Off: The weight can be stopped at a particular position by moving the valve position to off. This disconnects the port A and port B from the pressurized line and the retrieval line which locks the air in the cylinder.

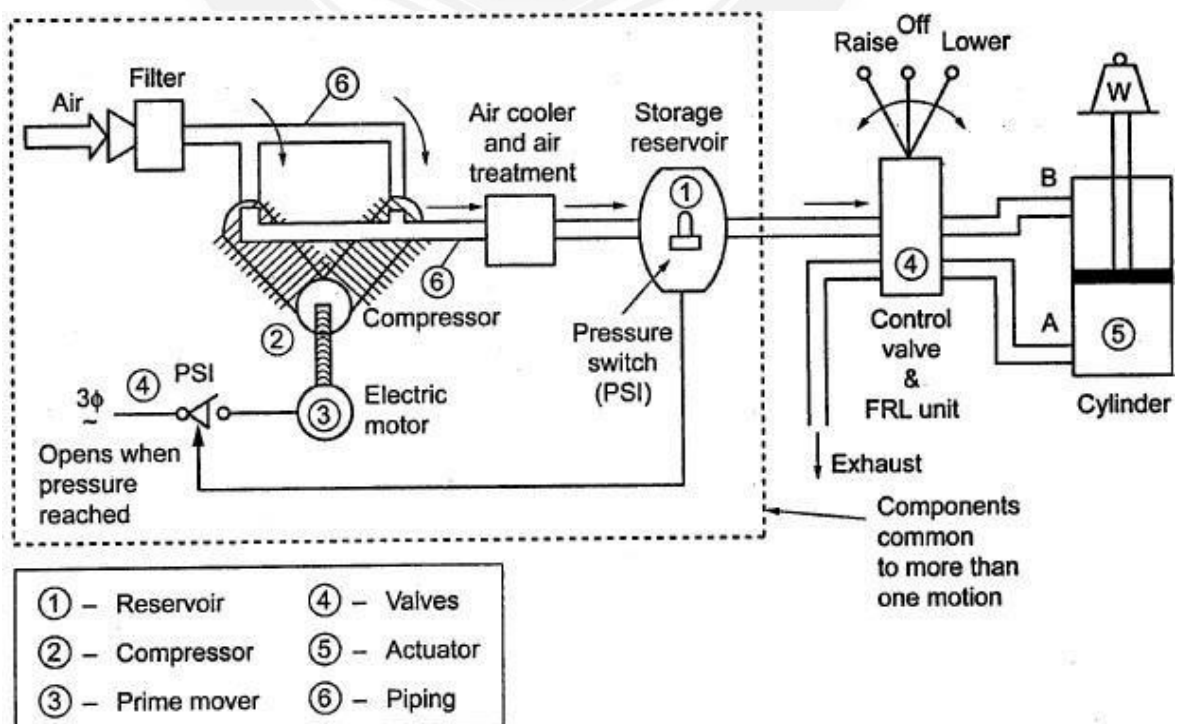

General arrangement of pneumatic system

COMPARISON BETWEEN HYDRAULIC, PNEUMATIC AND ELECTRO MECHANICAL POWER SYSTEM

Hydraulic System	Pneumatic System	Electro-Mechanical System
Pressurized Liquid is used	Compressed Air is used	Energy is transmitted through mechanical components
Energy stored in Accumulator	Energy stored in Tank	Energy stored in Batteries
Hydraulic Valves are used	Pneumatic Valves are used	Variable Frequency drives
Transmission through Hydraulic cylinders, Actuators	Transmission through Pneumatic cylinders, Actuators	Transmission through Mechanical components like Gears, Cams

Hydraulic System	Pneumatic System	Electro-Mechanical System
Flow rate is 2 to 6 m/s	Flow rate is 20-40 m/s	Excellent with minimum loss
More Precision	Less Precision	More Precision
Large force can be generated	Limited force can be achieved	Large force can be realized but poor in efficiency
Medium Cost	High cost	Low Cost
Dangerous and fire hazardous because of leakage	Noisy	Easy to work

FUNCTIONS OF FLUIDS IN A FLUID POWER SYSTEM:

1. Transfer fluid power efficiently
2. Lubricate the moving parts
3. Absorb, Carry and Transfer heat generated within the system
4. Be compatible with hydraulic components
5. Remain stable against physical and chemical changes.

VARIOUS HYDRAULIC FLUIDS:

- ❖ **Water:** The least expensive hydraulic fluid is water. Water is treated with chemicals before being used in a fluid power system. This treatment removes undesirable contaminants. **Advantages:** Inexpensive, Readily available, Fire resistance
Disadvantage: No lubricity, Corrosive, Temperature limitations
- ❖ **Petroleum Oils:** These are the most common among the hydraulic fluids which are used in a wide range of hydraulic applications. The characteristic of petroleum based hydraulic oils are controlled by the type of crude oil used. Naphthenic oils have low viscosity index so it is unsuitable where the oil temperatures vary too widely. The aromatics have a higher presence of benzene and they are more moderate temperature variation. Paraffinic oils have a high viscosity index and they are more suitable for the system where the temperature varies greatly.
Advantages: Excellent lubricity, Reasonable cost, Non-corrosive
Disadvantage: Tendency to oxidize rapidly, Not fire resistance
- ❖ **Water Glycols:** These are solutions contains 35 to 55% water, glycol and water soluble thickener to improve viscosity. Additives are also added to improve anticorrosion, anti wear and lubricity properties.
Advantages: Better fire resistance, Less expensive, Compatible with most pipe compounds and seals
Disadvantage: Low viscosity, Poor corrosion resistance, not suitable for high loads
- ❖ **Water Oil Emulsions:** These are water-oil mixtures. They are of two types oil-in-water emulsions or water-in-oil emulsions. The oil-in-water emulsion has water as the continuous base and the oil is present in lesser amounts as the dispersed media. In the water-in-oil

emulsion, the oil is in continuous phase and water is the dispersed media.

Advantages: High viscosity index, Oxidation stability, Film strength

Disadvantage: Depletion of water due to evaporation decreases fire resistance, Demulsification may be problem with water-in-oil emulsions.

❖ **Phosphate Ester:** It results from the incorporation of phosphorus into organic molecules. They have high thermal stability. They serve as an excellent detergent and prevent building up of sludge.

Advantages: Excellent fire resistance, Good lubricity, Non corrosive

Disadvantage: Not compatible with many plastics and elastomers, Expensive.

PROPERTIES OF FLUIDS:

1. Viscosity: It is a measure of the fluid's internal resistance offered to flow. Viscosity is the most important factor from the stand point of flow. If the viscosity of the hydraulic oil is higher than recommended, the system will be affected in the following manner.

1. The viscous oil may not be able to pass through the pipes.
2. The working temperature will increase because there will be internal friction.
3. The consumption of power will increase

If the viscosity of the oil is lesser than recommended then,

1. The internal and external leakage will increase
2. It cannot lubricate properly and will lead to rapid wear of the moving parts.

2. Viscosity Index: This value shows how temperature affects the viscosity of oil. The viscosity of the oil decreases with increase in temperature and vice versa. The rate of change of viscosity with temperature is indicated on an arbitrary scale called viscosity index (VI). The lower the viscosity index, the greater the variation in viscosity with changes in temperature and vice versa.

3. Oxidation Stability: The most important property of an hydraulic oil is its oxidation stability. Oxidation is caused by a chemical reaction between the oxygen of the dissolved air and the oil. The oxidation of the oil creates impurities like sludge, insoluble gum and soluble acidic products. The soluble acidic products cause corrosion and insoluble products make the operation sluggish.

4. Demulsibility: The ability of a hydraulic fluid to separate rapidly from moisture and successfully resist emulsification is known as Demulsibility. If oil emulsifies with water the emulsion will promote the destruction of lubricating value and sealant properties. Highly refined oils are basically water resistance by nature.

5. Lubricity: Wear results in increase clearance which leads to all sorts of operational difficulties including fall of efficiency. At the time of selecting a hydraulic oil care must be taken to select one which will be able to lubricate the moving parts efficiently.

6. Rust Prevention: The moisture entering into the hydraulic system with air causes the parts made ferrous materials to rust. This rust if passed through the precision made pumps and valves may scratch the nicely polished surfaces. So additives named inhibitors are added to the oil to keep the moisture away from the surface.

7. Pour Point: The temperature at which oil will clot is referred to as the pour point i.e. the lowest temperature at which the oil is able to flow easily. It is of great importance in cold countries where the system is exposed to very low temperature.

8. Flash Point and Fire Point: Flash point is the temperature at which a liquid gives off vapour in sufficient quantity to ignite momentarily or flash

when a flame is applied. The minimum temperature at which the hydraulic fluid will catch fire and continue burning is called fire point.

9. Neutralization Number: The neutralization number is a measure of the acidity or alkalinity of a hydraulic fluid. This is referred to as the PH value of the fluid. High acidity causes the oxidation rate in an oil to increase rapidly.

10. Density: It is that quantity of matter contained in unit volume of the substance.

11. Compressibility: All fluids are compressible to some extent. Compressibility of a liquid causes the liquid to act much like a stiff spring. The coefficient of compressibility is the fractional change in a unit volume of liquid per unit change of pressure.

REQUIRED QUALITIES OF GOOD HYDRAULIC OIL:

1. Stable viscosity characteristics
2. Good lubricity
3. Compatibility with system materials
4. Stable physical and chemical properties
5. Good heat dissipation capability
6. High bulk modulus and degree of incompressibility
7. Good flammability
8. Low volatility
9. Good demulsibility
10. Better fire resistance
11. Non toxicity and good oxidation stability
12. Better rust and corrosion prevent qualities
13. Ready availability and inexpensive