

TOPOLOGIES OF FEEDBACK AMPLIFIER

Basic amplifiers are voltage, current, transconductance, transresistance amplifier.

These can be connected in a feedback configuration as shown in figure.

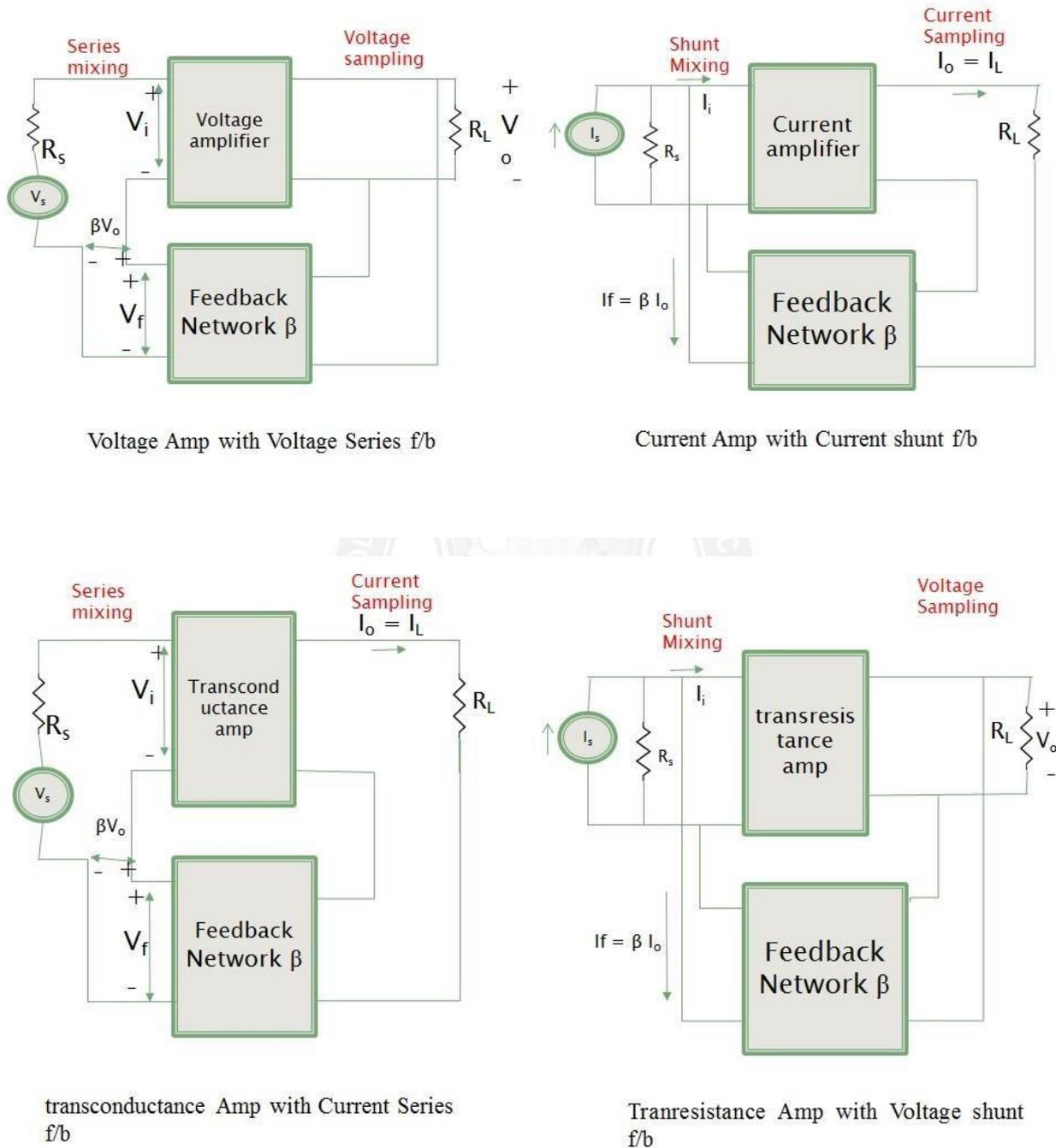

Fig 1. Feedback configuration

(Source: *Microelectronics by J. Millman and A. Grabel, , 2nd ed.,*)

Voltage Amplifier:

- Voltage amplifier is used to amplify input voltage signal and provide amplified input voltage at the output.
- Signal source is a voltage signal hence it is in thevenin's equivalent circuit.

- Feedback topology suitable for Voltage Amplifier is voltage sampling and series mixing.
- This topology is known as series-shunt feedback topology or voltage series feedback.

Current Amplifier:

- Current amplifier are used to amplify input current signal and provide amplified input Current at the output
- Signal source is a Current signal hence it in Norton's equivalent circuit
- Feedback topology suitable for Current Amplifier is Current sampling and Shunt mixing.
- This topology is known as shunt-series f/b topology or Current shunt f/b

Transconductance Amplifier:

- Transconductance amplifier with a thevenin's equivalent in its input circuit and Norton's equivalent in output circuit
- $$R_i \gg R_s, V_i = V_s ; \quad R_o \gg R_L, I_L = G_m V_i$$
- Feedback topology suitable for Voltage Transconductance Amplifier is Current sampling and series mixing.
 - This topology is known as series-series feedback topology or Current series feedback

Transresistance Amplifier:

- Transresistance amplifier with a Norton's equivalent in its input circuit and thevenin's equivalent in output circuit
- $$R_i \ll R_s, I_i = I_s ; \quad R_o \ll R_L, V_o = R_m V_i$$
- Feedback topology suitable for transresistance Amplifier is Voltage sampling and shunt mixing.
 - This topology is known as shunt-shunt feedback topology or voltage shunt feedback.

Voltage-Series Feedback

- In the voltage series feedback circuit, a fraction of the output voltage is applied in series with the input voltage through the feedback circuit.

- This is also known as **shunt-driven series-fed** feedback, i.e., a parallel-series circuit.
- The following figure.2 shows the block diagram of voltage series feedback, by which it is evident that the feedback circuit is placed in shunt with the output but in series with the input.

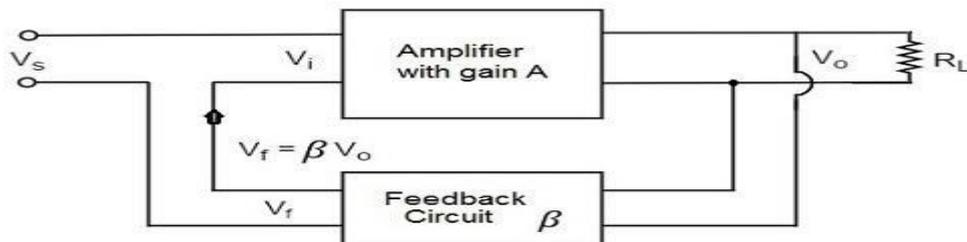

Fig.2. voltage series feedback circuit

(Source: Microelectronics by J. Millman and A. Grabel, , 2nd ed.,)

- As the feedback circuit is connected in shunt with the output, the output impedance is decreased and due to the series connection with the input, the input impedance is increased.

Voltage-Shunt Feedback

- In the voltage shunt feedback circuit, a fraction of the output voltage is applied in parallel with the input voltage through the feedback network.
- This is also known as **shunt-driven shunt-fed** feedback i.e., a parallel-parallel proto type.
- The below figure.3 shows the block diagram of voltage shunt feedback, by which it is evident that the feedback circuit is placed in shunt with the output and also with the input.

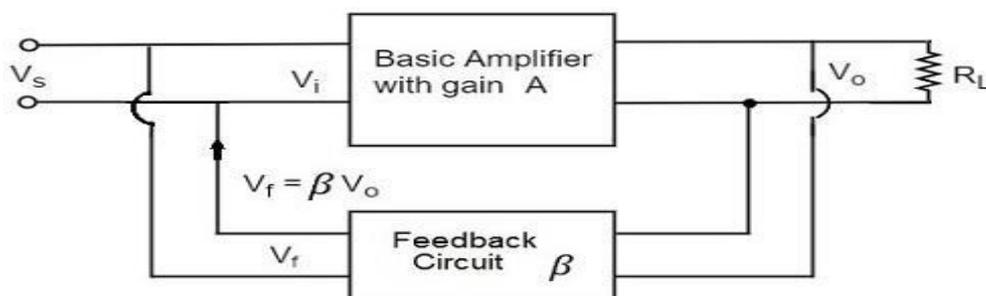

Fig.3. voltage shunt feedback circuit

(Source: Microelectronics by J. Millman and A. Grabel, , 2nd ed.,)

- As the feedback circuit is connected in shunt with the output and the input as well, both the output impedance and the input impedance are decreased.

Current-Series Feedback

- In the current series feedback circuit, a fraction of the output voltage is applied in series with the input voltage through the feedback circuit.
- This is also known as **series-driven series-fed** feedback i.e., a series-series circuit.
- The following figure.4 shows the block diagram of current series feedback, by which it is evident that the feedback circuit is placed in series with the output and also with the input.

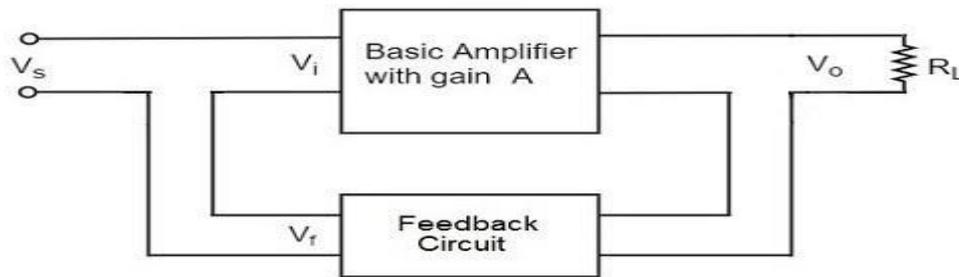

Fig.4. current series feedback circuit

(Source: "Microelectronics" by J. Millman and A. Grabel, , 2nd ed.,)

- As the feedback circuit is connected in series with the output and the input as well, both the output impedance and the input impedance are increased.

Current-Shunt Feedback

- In the current shunt feedback circuit, a fraction of the output voltage is applied in series with the input voltage through the feedback circuit.
- This is also known as **series-driven shunt-fed** feedback i.e., a series-parallel circuit.
- The below figure.5 shows the block diagram of current shunt feedback, by which it is evident that the feedback circuit is placed in series with the output but in parallel with the input.
- As the feedback circuit is connected in series with the output, the output impedance is increased and due to the parallel connection with the input, the input impedance is decreased.

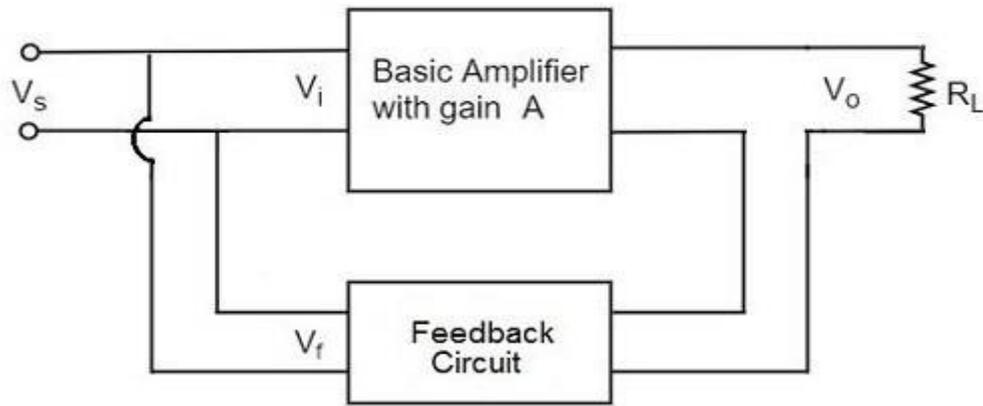

Fig.5. current shunt feedback circuit

(Source: "Microelectronics" by J. Millman and A. Grabel, 2nd ed.,)

- Let us now tabulate the amplifier characteristics that get affected by different types of negative feedbacks.

Characteristics	Types of Feedback			
	Voltage-Series	Voltage-Shunt	Current-Series	Current-Shunt
Voltage Gain	Decreases	Decreases	Decreases	Decreases
Bandwidth	Increases	Increases	Increases	Increases
Input resistance	Increases	Decreases	Increases	Decreases
Output resistance	Decreases	Decreases	Increases	Increases
Harmonic distortion	Decreases	Decreases	Decreases	Decreases
Noise	Decreases	Decreases	Decreases	Decreases