

SHAPER , PLANNER & SLOTTING MACHINES

SHAPER MACHINE

Introduction:

The shaper is a machine tool used primarily for:

1. Producing a flat or plane surface which may be in a horizontal, a vertical or an angular plane.
2. Making slots, grooves and key ways
3. Producing contour of concave/convex or a combination of these

Working Principle:

The job is rigidly fixed on the machine table. The single point cutting tool held properly in the tool post is mounted on a reciprocating ram. The reciprocating motion of the ram is obtained by a quick return motion mechanism. As the ram reciprocates, the tool cuts the material during its forward stroke. During return, there is no cutting action and this stroke is called the idle stroke. The forward and return strokes constitute one operating cycle of the shaper.

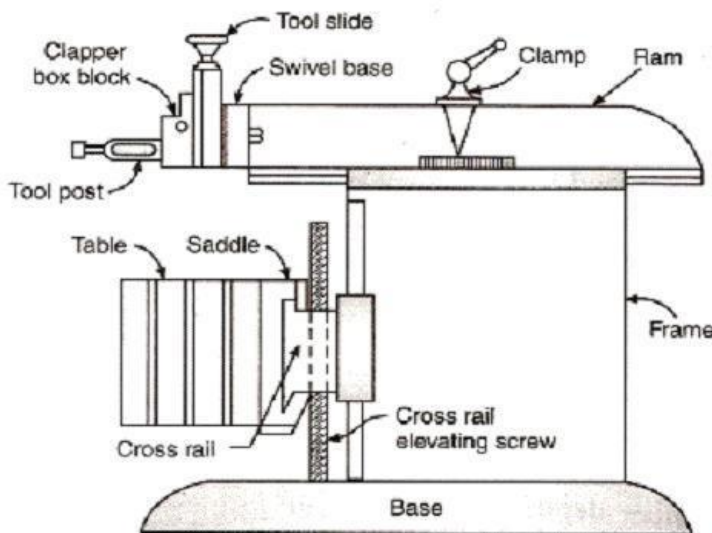

Construction:

The main parts of the Shaper machine is Base, Body (Pillar, Frame, Column), Cross rail, Ram and tool head (Tool Post, Tool Slide, Clamper Box Block).

Base:

It is the main body of the machine. It consist all element of machine. It works as pillar for other parts. Base is made by cast iron which can take all compressive loads.

Ram:

It is the main part of the shaper machine. It holds the tool and provides the reciprocating motion to it. It is made by cast iron and move over ways on column. It is attached by the rocker arm which provide it motion in crank driven machine and if the machine is hydraulic driven it is attached by hydraulic housing.

Tool head:

It is situated at the front of the ram. Its main function is to hold the cutting tool. The tool can be adjusted on it by some of clamps.

Table:

It is the metal body attached over the frame. Its main function is to hold the work piece and vice over it. It has two T slots which used to clamp vice and work piece over it.

Clapper box:

It carries the tool holder. The main function of clapper box is to provide clearance for tool in return stock. It prevents the cutting edge dragging the work piece while return stock and prevent tool wear.

Column:

Column is attached to the base. It provides the housing for the crank slider mechanism. The slide ways are attached upper section of column which provide path for ram motion.

Cross ways:

It consist vertical and horizontal table sideways which allow the motion of table. It is attach with some cross movement mechanism.

Stroke adjuster:

It is attached below the table. It is used to control the stroke length which further controls the ram movement.

Table supports:

These are attached front side of the table and used to support the weight of table during working.

Types of Shaper:

Shapers can classified into many types based on several criteria:

1) Based on the type of driving mechanism used

- a) Crank and slotted lever driving mechanism type
- b) Whitworth quick return driving mechanism type
- c) Hydraulic driving mechanism type

2) Based on the table design

- a) Plain Shaper
- b) Universal Shaper

3) Based on the position of the reciprocating ram used

- a) Horizontal shaping machine (Most common type of shaper used)
- b) Vertical shaping machine
- c) Travelling head shaping machine

4) Based on the type of cutting stroke of the tool

- a) Push out type
- b) Draw cut type

Types of operations performed in a shaper

1. Machining horizontal surface.
2. Machining vertical surface.
3. Machining angular surface.
4. Cutting slots, grooves and keyways.
5. Machining irregular surface.
6. Machining splines or cutting gear.

Quick Return Mechanism -Types

A quick return mechanism is an system to produce a reciprocating effect such that time taken by system in return stroke is less time taken by it in the forward stroke.

In quick return mechanism, a circular motion is converted into reciprocating motion just like crank and lever mechanism but it has return stroke time is different from forward stroke time.

This mechanism is used in many machines. Some of them are shaper machines, slotter machines, screw press, mechanical actuator etc. With the help of quick return mechanism, the time needed to cutting is minimized.

Types of Quick Return Mechanism:-

1 Hydraulic Drive:

Hydraulic drive mechanism is one of the mechanism used in shaper machine. In this mechanism, the ram is moved forward and backward by a piston moving in a cylinder placed under the ram.

This machine consists of a constant discharge oil pump, a cylinder , a valve chamber and a piston. The piston rod is bolted to the the ram body. Hydraulic fluid is used in hydraulic quick return mechanism for the movement of ram.

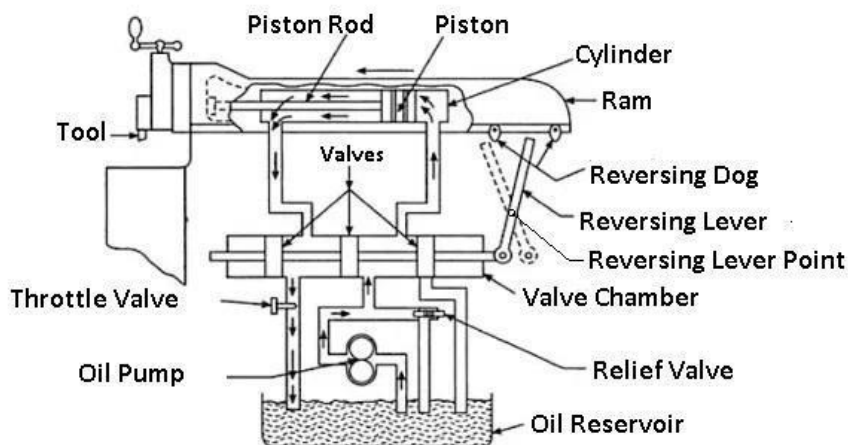

Working of Hydraulic Drive :-

In hydraulic drive, there is a tank at the bottom which contains the hydraulic fluid. This tank is also known as oil reservoir. At first the oil from the reservoir. This oil is passed through the valve chamber present in the right of the oil cylinder exerting pressure on the piston. Any oil present in the left side of the piston is discharged to

the reservoir through the throttle valve.

At first the fluid in the tank is pumped out and this fluid passes through the passage present in the right side of the cylinder .

This fluid exerts pressure on the piston and the ram of the machine performs forward stroke.

When the ram moves forward, the lever changes its position and hits the reversing dog. As the lever changes its position, the three valves connected to the lever also change their position and now the oil can pass through the passage present in the left side of the cylinder.

After the forward stroke is completed, the valves changes its position and now the pumped fluid from the reservoir moves from the passage present in the left side of the piston. Also, the passage through which the oil return to the reservoir opens and get connected to the right passage and the fluid present on the right side of the piston is discharge to the reservoir.

As the fluid moves towards the left side of the piston, the piston which is attached to the ram moves towards right and return stroke is performed by the ram.

At the end of the return stroke, another dog hit against the lever and the direction of the lever as well as the stroke changes. In this way, the forward and the return stroke of the ram is repeated.

The quick return takes place due to difference in the stroke volume of cylinder at both ends. The volume of passage at the left side is less than the volume of the passage on the right side. As the pump is constant discharge pump, same amount of oil will be passed on the both passage. So the pressure n the passage with less volume will be more and the return stroke will be faster than the forward stroke.

The cutting speed can be controlled by controlling the flow of oil which can be controlled by using the throttle valve.

2. Whitworth Quick Return mechanism :-

This mechanism changes the rotary motion to oscillatory motion like the crank and lever mechanism.

The difference between the crank and lever mechanism and Whitworth mechanism is that in whitworth mechanism the return stroke is faster than the forward stroke while in the crank and lever mechanism the forward stroke is of same speed as that of return stroke.

Parts used in Whitworth mechanism :-

- 1) Slotted Bar.
- 2) Slider
- 3) Crank – It will rotate.

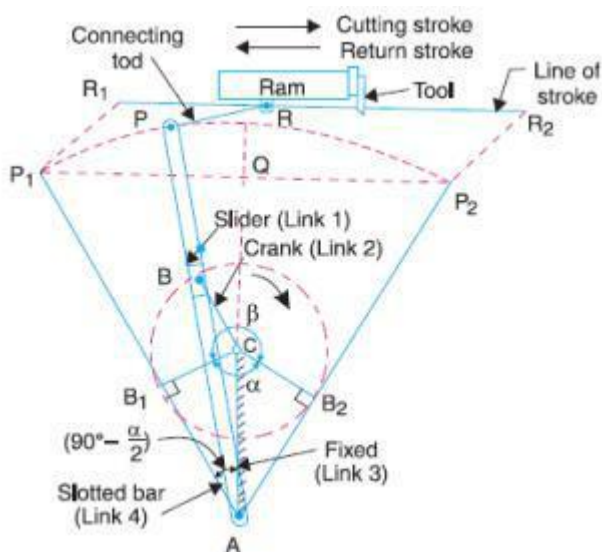

Whitworth quick return mechanism is the second inversion of slider crank mechanism in which the crank is fixed.

In this mechanism, the Slider in slotted bar is connected to the crank. When the crank rotates, the slider will slide inside the slotter bar and the slotted bar will oscillate. As the slotted bar oscillate, the ram will move in forward and backward direction.

The return stroke or ideal is faster than the forward stroke in this mechanism.

In the above figure AP is the slotted bar and link 1, CD is link 2, AC which is crank is link 3 and link 4 is the slider.

In this mechanism the link CD i.e link 2 forming the turning pair is fixed as shown in the figure above.

The crank AC revolves with uniform velocity with its centre at A.

A sliding block attached to the crank pin at B slides along the slotted bar AP and thus causes Ap to oscillate about the pivoted pint A. A short link PR transmits the motion from AP to the ram which carries the tool and thus forward stroke and backward stroke is obtained.

The crank needs to rotate through an angle of (β) for the forward stroke and it needs to rotate through an angle of (α) for forward stroke.

As crank moves with uniform angular velocity, time taken to cover angle α will be less than the time taken to cover angle β . Hence time taken in return stroke will be less than time taken in forwaed stroke. In this way, the quick return mechanism works.

3) Crank and Slotted Link Mechanism:-

In crank and slotted link mechanism. The power is transmitted to the bull gear by a pinion which recieves its power from an individual motor.

In a two gear system, the smaller gear is called pinion and the larger gear is called bull gear.

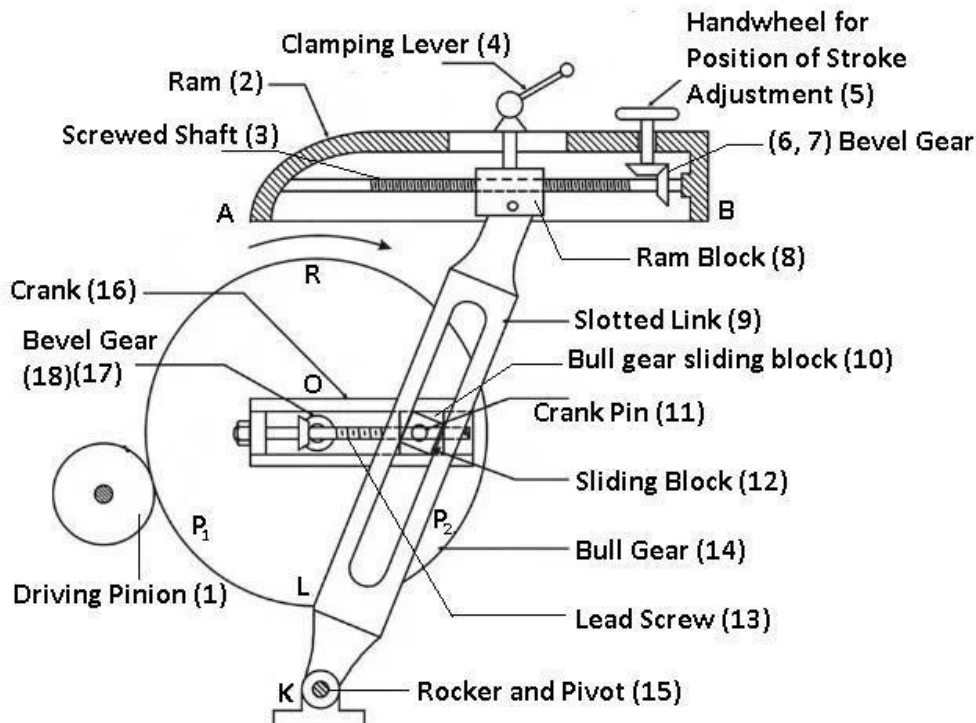

Working of Crank and Slotted Link Mechanism:-

The radial slide is bolted to the centre of the bull gear. This radial slide carries a sliding block into which the

crank pin is fitted.

As the bull gear will rotate, the crank will revolve at uniform speed.

The sliding block which is mounted upon the crank pin is fitted upon the crank pin is fitted within the slotted link. This slotted link is pivoted upon at its bottom end attached to the frame of column. The upper end of the sliding link is bifurcated and attached to the ram block by a pin.

When the bull gear rotates, the crank pin revolves at a uniform speed. The sliding block fastened to the crank pin will rotate on the crank pin circle and at the same time this slider will slide up and down in the sliding link.

As the slider will move inside the sliding link, it will provide a rocking movement to the sliding link and this movement will be transferred to the ram providing it a reciprocatory motion.

Hence the rotary motion of the bull gear is converted into reciprocatory motion of ram.

Automatic Table feeding mechanism of shaper

The automatic feed mechanism of the table is very simple. This is done by rotating a ratchet wheel, mounted at the crossfeed screw. This enables a corresponding equal rotation of the crossfeed screw after each stroke.

Arrangement of parts

It consists of a slotted disc, which carries a T-slot, as shown in the figure. In this slot is fitted an adjustable pin and to this is attached a connecting rod. The other end of the connecting rod is attached to the lower end of the rocker arm of the pawl mechanism.

The rocker arm swings about the screw C, and at its upper end carries a spring-loaded pawl, as shown.

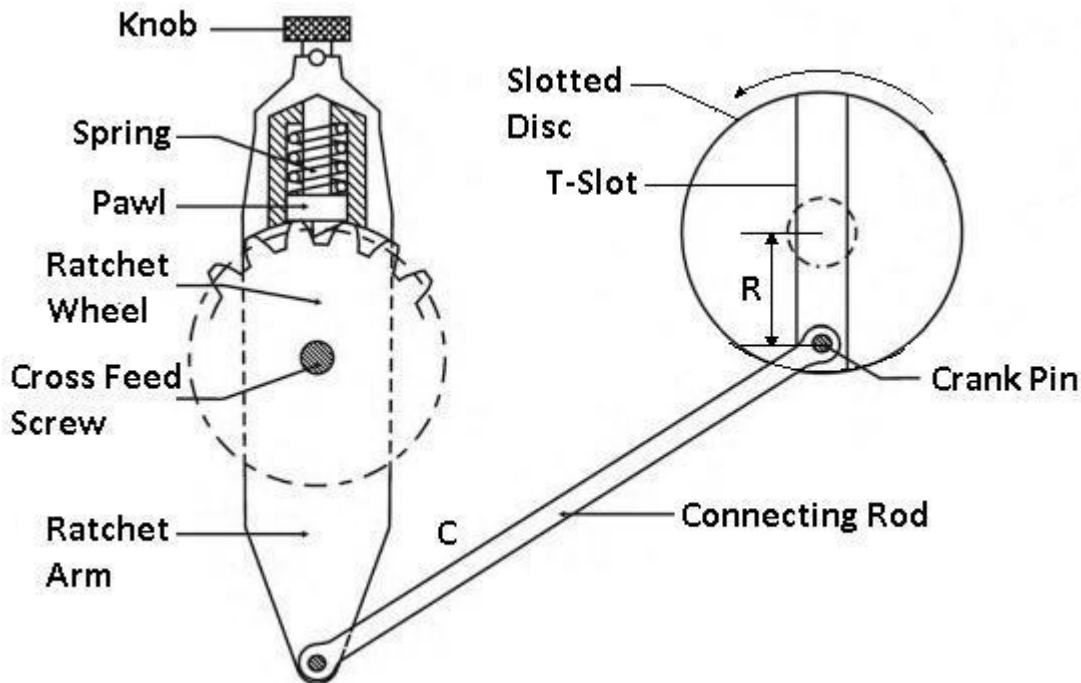

Working

Note, that the lower end of the pawl is bevelled on one side.

This arrangement helps the power feed to operate in either direction, but the same should be set to operate during the return stroke only. If otherwise, the mechanism will be subjected to severe stress. In some latest types of shapers, can driven feed mechanisms are provided which are more efficient and provide a wider range of feed.

Variation in the feed can be provided by varying the distance R between the disc centre and the centre of the adjustable pin. Larger the said distance greater will be the feed and vice versa. The amount of feed to be given depends upon the type of finish required on the job.

For rough machining, heavier cuts are employed, and thus, a coarse feed is needed. Against this, a finer feed is employed in finishing operations.

The slotted disc at its back carries a spur gear which is driven by the bull gear. As the disc rotates through this gear the adjustable pin, being eccentric with the disc centre.

This causes the connecting rod to reciprocate. This, in turn, makes the rocker arm to swing about the screw C to move the pawl over one or more teeth. Thus transmit an intermittent motion to the crossfeed screw which moves the table.

Shaper Machine – Specifications

- a. Length of Ram stroke: (457 mm)
- b. Range of Ram speeds: (12, 24, 40 & 72 strokes per minute)
- c. Working surface of table: (483 mm * 330 mm)
- d. Max Table Travel – Horizontal: (610 mm)
- e. Max Table Travel – Vertical: (457 mm)
- f. Angular movement of table on either side: (600)
- g. Maximum size of Tool Shank in Tool Head: (51m * 21mm)
- h. Maximum vertical travel of Tool Slide: (152 mm)
- i. Maximum swivel of Tool Head: (600)
- j. Main Drive Motor: (3 H.P./ 950 rpm)

CUTTING PARAMETERS OF A SHAPER

Cutting Speed

It is defined as the average linear speed of the tool during the cutting stroke in m/min, which depends on number of ram strokes (or ram cycles) per minute and length of the stroke.

Feed

Feed f is the relative motion of the work piece in a direction perpendicular to the axis of the reciprocation of the arm. In shaper, feed is normally given to the work piece and can be automatic or manual. It is expressed in mm/double stroke or simply mm/stroke because no cutting is done in return stroke.

Depth of Cut

Depth of cut d is the thickness of the material removed in one cut, in mm.

PLANER MACHINE

The planer or planing machine is a machine tool, which like the shaper produces flat surfaces in horizontal, vertical or inclined plane.

The fundamental difference is that the planer operates with an action opposite to that of the shapers, i.e., the work piece reciprocates past one or more stationary single point cutting tools.

Planers are meant for machining large sized work pieces, which cannot be machined by the shaping machines. The work table is moved back and forth on the bed beneath the cutting head either by mechanical means, such as a rack and pinion gear or by a hydraulic cylinder.

CLASSIFICATION OF PLANNER

Planers are generally divided into 5 types

- 1) Double housing planer
- 2) Open side planer
- 3) Edge type planer
- 4) Divide table planer
- 5) Pit type planer

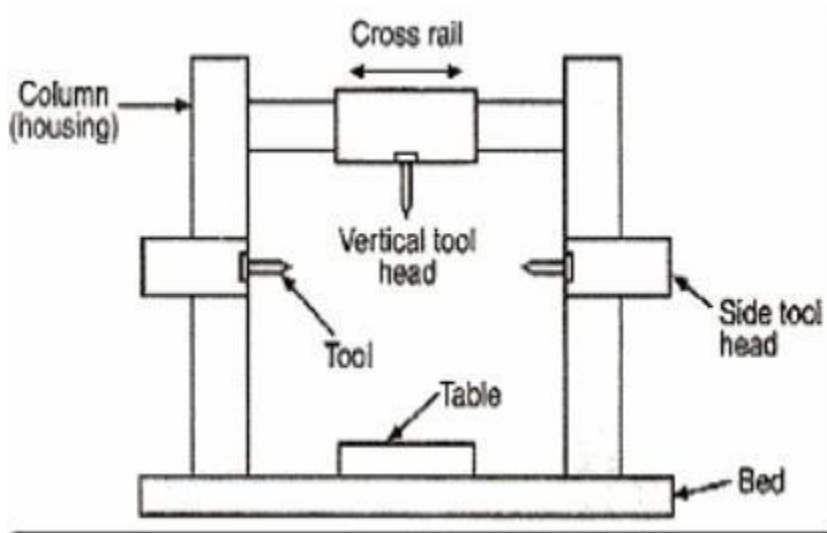

Parts of Planner

1) **BED**

Bed of a planer is large in size and heavy in weight. It supports the column and all other moving parts of machine. It is made slightly longer than twice the length of the table may be moved

on it. There is a v shaped ways on the bed which help to reciprocate or back and forth motion to the table.

2) TABLE

Table supports the work and reciprocates along the bed. Table is made from cast iron. The top face of the table is accurately finished in order to locate the work correctly. T-slots are provided on the entire length of the table so that the work and work holding devices may be bolted upon it.

3) COLUMN

These are rigid box like vertical structure placed on each side of the bed and table. They are heavily ribbed to trace up severe force due to cutting. It also facilitate tool head mechanism. The cross rail may be made to slide up and down for accommodating different heights of work.

4) CROSS RAIL

It is rigid box like casting connecting the two columns. It may be raised or lowered on the face of housing and can be clamped at a desired position by manual or electrical clamping devices. It should remain absolutely parallel to the top surface of the table.

5) TOOL HEAD

Tool heads are mounted on the crossrail by saddle. The saddle may be made to move transversely on the cross rail to give cross feed. The clapper block is hinged at hinge pins to the clapper block and it holds the tool post in which the tool is clamped by straps.

Work Holding devices used in Planner

- a) Heavy duty vices
- b) T-bolts and Clamps
- c) Step blocks, T-bolts and Clamps
- d) Poppets or stop pins and dogs
- e) Angle plates
- f) Planer centers
- g) Planer Jacks
- h) V- blocks
- i) Stops

Planer Tools

- a. Right hand, left hand - Straight roughing tools
- b. Right hand, left hand - Bent roughing tools
- c. Straight, Round nose, square nose and Goose neck - Finishing tools
- d. Grooving or slotting tool
- e. T-slot cutting tool
- f. Dovetail slide cutting tool

Specification of a Planer

1. Number of speeds and feeds available.
2. Power Input
3. Floor space required
4. Net weight of the machine
5. Type of drive

Cutting Parameters of Planner machine

- **Cutting speed** - It is the rate at which the metal is removed during forward cutting stroke and is expressed in m/min
- **Feed** - It is the distance the tool head travels per double stroke at the beginning of each cutting stroke and is expressed in mm
- **Depth of cut** - It is the thickness of metal removed in one cut. It is measured by the perpendicular distance between machined and unmachined surfaces of the work. It is given in mm.

PLANER OPERATIONS

1. Planing Horizontal Surfaces.
2. Planing Vertical Surfaces.
3. Planing curved surfaces.
4. Planing slots and grooves.
5. Planing at an angle and machining dove-tails.
6. Planing a helix.
7. Gang or multiple planing.

Difference b/w planer and shaper

Shaper machine	Planer machine
In shaper ram moves in reciprocating and back and fourth	Platen/table reciprocates moves and also moves back and fourth
In shaper cutting tool moves back and forth	In planer work piece moves in back and forth
Used for the machining of small jobs	Used for the machining of large jobs
Each stroke of cutting tool ,gives the feed in cross wise.	In Each stroke of Platen or work piece feed are given by feed screw.
For the adjustment of Ram stroke crank mechanism are used	For the adjustment of platen gears and rack mechanism are used
Only one tool are used	Two or more tools are used
In shaper cutting speed ,feed range are in wide range	In planer machine cutting speed , cutting feed are limited

SLOTTER MACHINE

Slotting machine (slotter) is a reciprocating type of machine tool similar to a shaper or a planer machine. It may be considered as a vertical shaper. The main difference between a slotter and a shaper is the direction of the cutting action. The slotting machine operates in a manner similar to the shaper. However, the cutting tool moves vertically direction rather than in a horizontal direction. The work piece is held stationary. The slotting machine has a vertical ram and a hand or power operated rotary table.

Principal Parts of a Slotting Machine:

Below figure shows a slotting machine and its various parts. The main parts of a slotting machine are discussed as under:

Bed or case: Bed or case is made up of cast iron. It supports column, tables, ram, driving mechanism, etc. the top of the bed carries horizontal ways which the worktable can transverse.

Cross-slide: Cross-slide can be moved parallel to the face of the column. The circular worktable is mounted on the top of the cross-slide.

Hand wheels: Hand wheels are provided for rotating the table for the longitudinal and cross traverse.

Column is the vertical member: They are made up of cast iron and it houses the driving mechanism. The vertical front face of the column is accurately finished for providing ways along which the ram moves up and down.

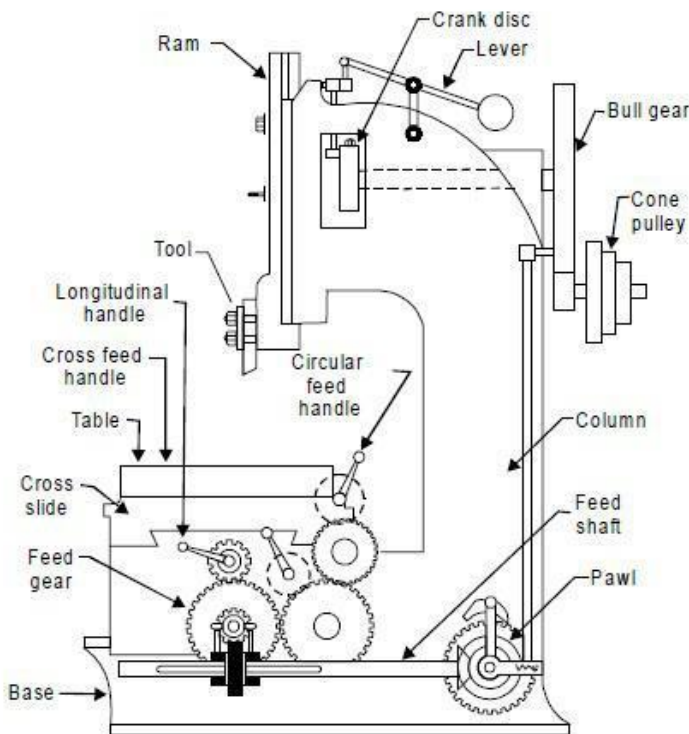

Ram: Ram is provided to reciprocate to and fro motion. At the bottom of the ram, it carries the cutting tool. It is more massive and moves vertically, at a right angle to the worktable, instead of having the horizontal motion of a shaper.

Table: Table holds the workpiece and is adjustable in longitudinal and crosswise direction. The table can be rotated about its center.

Operations Performed on a Slotting Machine:

A slotting machine is a very economical machine tool when used for certain classes of work given as under.

1. The slotting machine can be used to cut slots, splines keyways for both internal and external jobs such as machining internal and external gears.
2. It can be used for shaping internal and external forms or profiles.
3. It can be used for works as machining concave, circular, semi-circular and convex surfaces.
4. It can be used for machining vertical surfaces, machining angular or inclined surfaces, machining of shapes which are difficult to produce on a shaper machine and machining dies and punches.
5. It can be used for internal machining of blind holes.
6. It is used for machining dies and punches.

DRIVE MECHANISM OF SLOTTER

There are four types of driving mechanisms used in slotter for driving the ram,

- i. Slotted disc mechanism.
- ii. Slotted link mechanism.
- iii. Variable speed reverse motor driving mechanism.
- iv. Hydraulic drive mechanism.

SPECIFICATION OF A SLOTTER

- a. The maximum stroke length.
- b. Diameter of rotary table.
- c. Maximum travel of saddle and cross slide.
- d. Type of drive used.
- e. Power rating of motor.
- f. Net weight of machine.
- g. Number and amount of feeds
- h. Floor area required.

Work Holding Devices in Slotter.

- Vice
- T-Bolts and clamps
- Special Fixtures

Slotter Tools

- Bit Tools
- Round nose tools for machining contoured surface
- Square nose tools for flat surfaces.

Cutting Parameters of Slotting machine

- **Cutting speed** - It is the rate at which the metal is removed during downward cutting stroke and is expressed in m/min
- **Feed** - It is the distance the work travels per double stroke at the beginning of each cutting stroke and is expressed in mm .
- **Depth of cut** - It is the thickness of metal removed in one cut. It is measured by the perpendicular distance between machined and unmachined surfaces of the work. It is given in mm.