

## 1.1 OPEN AND CLOSED LOOP SYSTEM

In recent years, control systems have gained an increasingly important role in the development and advancement of the modern civilization and technology. Figure shows the basic components of a control system. Disregard the complexity of the system; it consists of an input (objective), the control system and its output (result). Practically our day-to-day activities are affected by some type of control systems. There are two main branches of control systems:

- 1) Open-loop systems and 2) Closed-loop systems

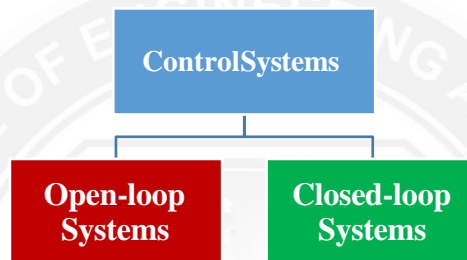

**Figure 1.2.1 Classification of Control Systems**

### OPEN LOOP SYSTEMS

A control system that cannot adjust itself to the changes is called an open-loop control system. In general, manual control systems are open-loop systems. The block diagram of an open-loop control system is shown in figure.

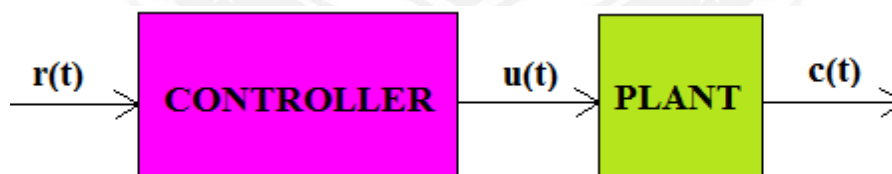

**Figure 1.2.2 Block diagram of open loop system**

Here,  $r(t)$  is the input signal,  $u(t)$  is the control signal /actuating signal and  $c(t)$  is the output signal. In this system, the output remains unaltered for a constant input. In case of any discrepancy, the input should be manually changed by an operator. An open-loop control system is suited when there is tolerance for fluctuation in the system and when the system parameter variation can be handled irrespective of the environmental conditions.

### PRACTICAL EXAMPLES OF OPEN LOOP CONTROL SYSTEM

1. Electric Hand Drier- Hot air(output) comes out as long as you keep your hand under the machine, irrespective of how much your hand is dried.

2. Automatic Washing Machine – This machine runs according to the pre- set time irrespective of washing is completed or not.
3. Bread Toaster- This machine runs as per adjusted time irrespective of toasting is completed or not.
4. Automatic Tea/Coffee Maker- These machines also function for preadjusted time only.
5. Timer Based Clothes Drier- This machine dries wet clothes for pre-adjusted time, it does not matter how much the clothes are dried.
6. Light Switch- Lamps glow whenever light switch is on irrespective of light is required or not.
7. Volume on Stereo System-Volume is adjusted manually irrespective of output volume level.

### **Advantages of Open Loop Control System**

- a) Simple in construction and design
- b) Economical
- c) Easy to maintain
- d) Generally stable
- e) Convenient to use as output is difficult to measure.

### **Disadvantages of Open Loop Control System**

- a) They are in accurate
- b) They are unreliable
- c) Any change in output cannot be corrected automatically.

### **CLOSED LOOP SYSTEMS**

Any system that can respond to the changes and make corrections by itself is known as closed loop control system. The only difference when compared to open loop system is the presence of feed back action. The block diagram of a closed loop system is shown in the figure. Here,  $r(t)$  is the input signal,  $e(t)$  is the error signal/ actuating signal,  $e(t)$  is sent to the controller. Based on the error, the control adjusts the air conditioners input [control signal  $u(t)$ ]. This process is continued till error gets nullified.

$u(t)$  or  $m(t)$  is the control signal/manipulated signal,  $b(t)$  is the feedback signal and  $c(t)$  is the controlled output. Here, the output of the machine is fed back to a comparator (error detector). The output signal is compared with the reference input,  $r(t)$  and the error signal,

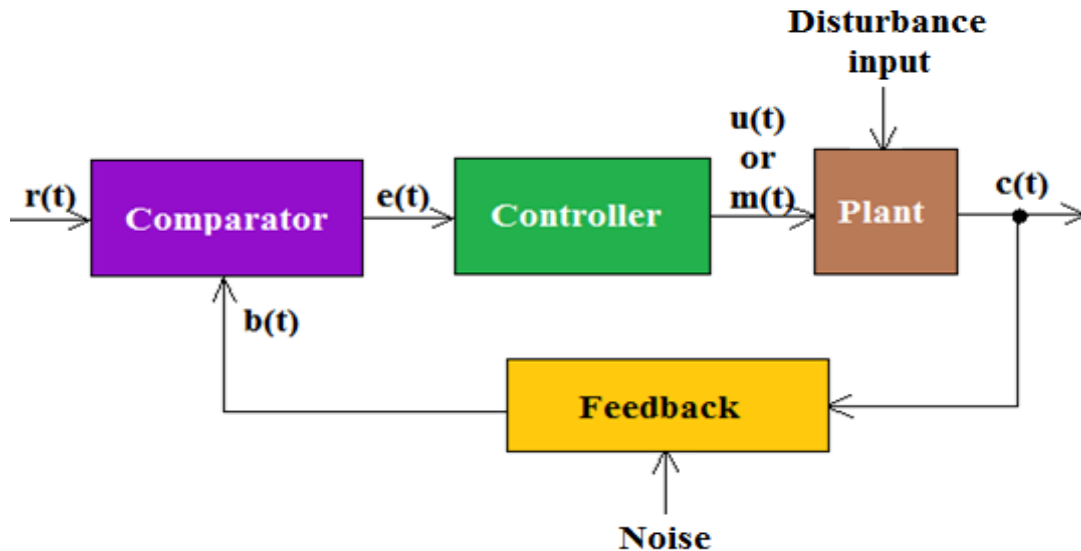

**Figure 1.2.3 Block diagram of closed loop system**

Both the manual and automatic controls can be implemented in a closed loop system.

### **PRACTICAL EXAMPLES OF CLOSED LOOP CONTROL SYSTEM**

- 1) Automatic Electric Iron-Heating elements are controlled by output temperature of the iron.
- 2) Servo Voltage Stabilizer-Voltage controller operates depending upon output voltage of the system.
- 3) Water Level Controller-Input water is controlled by water level of the reservoir.
- 4) Missile Launched and Auto Tracked by Radar- The direction of missile is controlled by comparing the target and position of the missile.
- 5) An Air Conditioner-An air conditioner functions depending upon the temperature of the room.
- 6) Cooling System in Car-It operates depending upon the temperature which it controls.

### **Advantages of Closed Loop Control System**

- a) Closed loop control systems are more accurate even in the presence of non-

linearity.

- b) Highly accurate as any error arising is corrected due to presence of feedback signal.
- c) Band width range is large.
- d) Facilitates automation.
- e) The sensitivity of system may be made small to make system more stable.
- f) This system is less affected by noise.

**Disadvantages of Closed Loop Control System**

- a) They are costlier.
- b) They are complicated to design.
- c) Required more maintenance.
- d) Feedback leads to oscillatory response.
- e) Overall gain is reduced due to presence of feedback.
- f) Stability is the major problem and more care is needed to design a stable closed loop system.

S.No.	Open loop control system	Closed loop control system
1	Inaccurate	Accurate
2	Unreliable	Reliable
3	Stable	Unstable. It can be stabilized using the feedback or by reducing sensitivity
4	Bandwidth is small	Band width is large
5	System is affected by noise	System is less affected by noise
6	Cheap	Costly
7	Simple in construction	Complex constructions in greater number of components are present
8	Requires less maintenance	Requires more maintenance
9	Overall gain is high	Overall high is reduced due to feedback