

1.3 MECHANICAL TRANSLATIONAL AND ROTATIONAL SYSTEMS

The general classification of mechanical system is of two types namely translational and rotational systems.

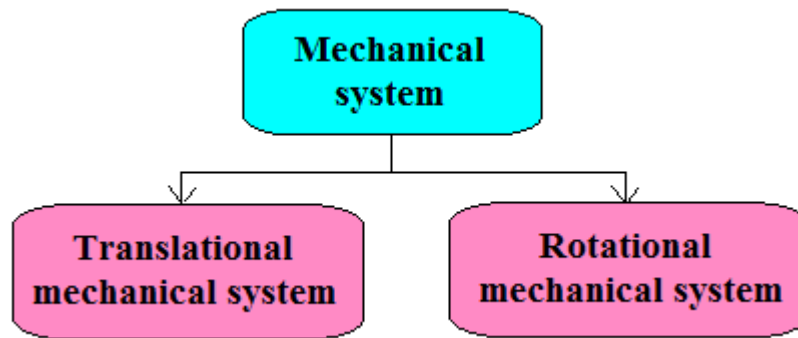

Figure 1.3.1 Classification of mechanical system

[Source: "Control Systems Engineering" by S.Salivahanan, R.Rengaraj, G.R.Venkatakrishnan, Page: 1.21]

MECHANICAL TRANSLATIONAL SYSTEMS

The model of mechanical translational systems can obtain by using three basic elements mass, spring and dashpot. When a force is applied to a translational mechanical system, it is opposed by opposing forces due to mass, friction and elasticity of the system. The force acting on a mechanical body is governed by Newton's second law of motion. For translational systems it states that the sum of forces acting on a body is zero.

Force balance equations of idealized elements:

Inertia force, $f_m(t)$

Consider an ideal mass element shown in figure, which has negligible friction and elasticity. Let a force be applied on it. The mass will offer an opposing force which is proportional to acceleration of a body.

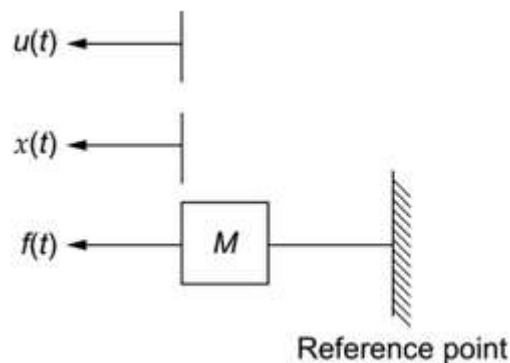

Figure 1.3.2 Mechanical translational element: Mass

[Source: "Control Systems Engineering" by S.Salivahanan, R.Rengaraj, G.R.Venkatakrishnan, Page: 1.21]

Let $f(t)$ - applied force, f_m - opposing force due to mass,

$$f_m \propto \frac{d^2x}{dt^2}$$

By Newton's second law,

$$f = f_m = M \frac{d^2x}{dt^2}$$

Damper force, $f_b(t)$

Consider an ideal frictional element dash-pot shown in fig. which has negligible mass and elasticity. The dashpot's opposing force which is proportional to velocity of the body.

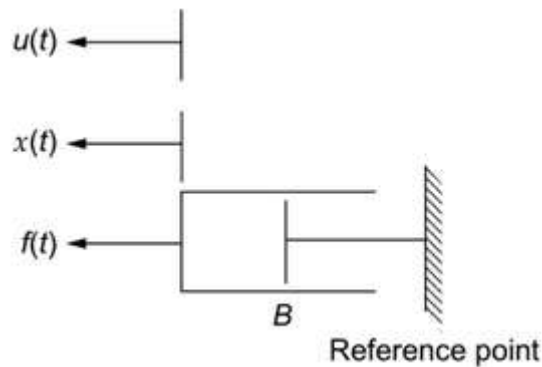

Figure 1.3.3 Mechanical translational element: Dashpot

[Source: "Control Systems Engineering" by S.Salivahanan, R.Rengaraj, G.R.Venkatakrishnan, Page: 1.23]

Let f = applied force, f_b = opposing force due to friction

$$f_b \propto \frac{dx}{dt}$$

By Newton's second law,

$$f = f_b = B \frac{dx}{dt}$$

Spring force, $f_k(t)$

Consider an ideal elastic element spring is shown in fig. This has negligible mass and friction.

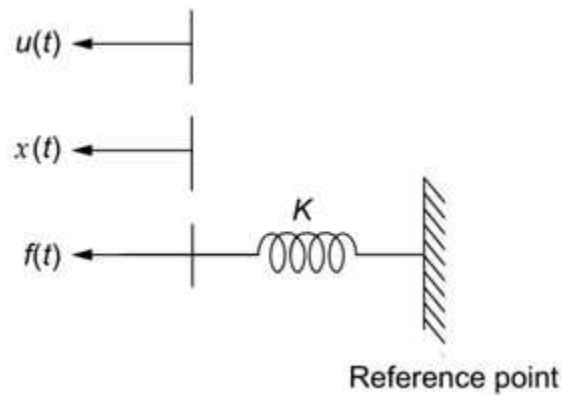

Figure 1.3.4 Mechanical translational element: Spring

[Source: "Control Systems Engineering" by S.Salivahanan, R.Rengaraj, G.R.Venkatakrishnan, Page: 1.24]

Let f = applied force, f_k = opposing force due to elasticity

$$f_k \propto x$$

By Newtons second law,

$$f = f_k = Kx$$

According to D'Alembert's principle, "The algebraic sum of the externally applied forces to any body is equal to the algebraic sum of the opposing forces restraining motion produced by the elements present in the body." A simple translational mechanical system and its free body diagram are shown in figures 1.3.5 (a) and (b) respectively.

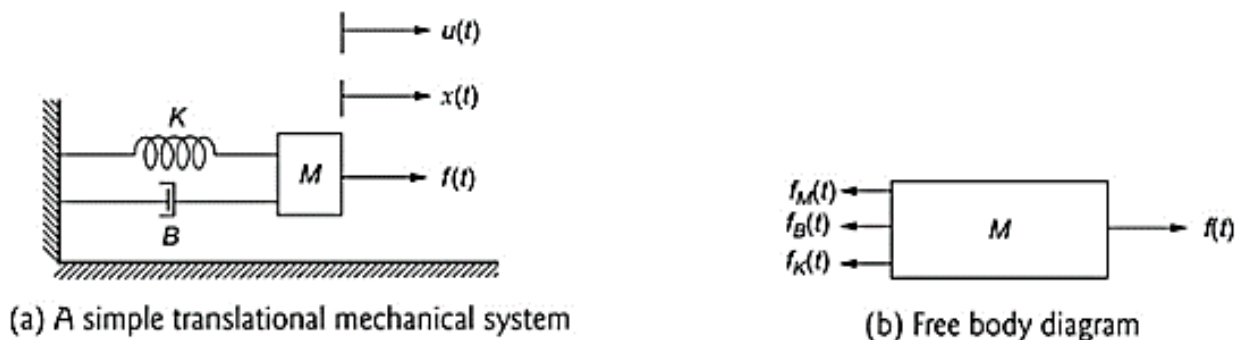

Figure 1.3.5 Mechanical translational system and its free body diagram

[Source: "Control Systems Engineering" by S.Salivahanan, R.Rengaraj, G.R.Venkatakrishnan, Page: 1.25]

$$f_m = M \frac{d^2x}{dt^2}$$

$$f_b = B \frac{dx}{dt}$$

$$f_k = Kx$$

$$f(t) = f_m + f_b + f_k = M \frac{d^2x}{dt^2} + B \frac{dx}{dt} + Kx$$

MECHANICAL ROTATIONAL SYSTEM

The modeling of a linear passive rotational mechanical system can be obtained by using three basic elements: inertia, rotational spring and rotational damper. The modeling of a rotational mechanical system is similar to that of a translational mechanical system except that the elements undergo a rotational instead of a translational movement. The opposing torques due to inertia, rotational spring and rotational damper act on a system when the system is subjected to a torque. Using D'Alembert's principle, for a linear passive rotational mechanical system, the sum of all the torques acting on a body is zero (i.e., the sum of applied torques is equal to the sum of the opposing torques on a body). Angular displacement, angular velocity and angular acceleration are the variables used to describe a linear passive rotational mechanical system. In rotational mechanical systems, the energy storage elements are inertia and rotational spring and the energy dissipating element is the rotational viscous damper. The analogous of the energy storage elements in an electrical circuit are the inductors and the capacitors and the analogous of energy dissipating element in an electrical circuit is the resistor.

Torque balance equations of idealized elements:

Inertia Torque, $T_j(t)$

When a torque $T(t)$ is applied to an inertia element J , it experiences an angular acceleration and it is shown in figure 1.3.6.

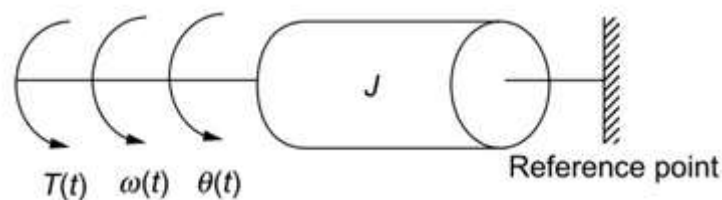

Figure 1.3.6 Mechanical rotational element: Inertia

[Source: "Control Systems Engineering" by S.Salivahanan, R.Rengaraj, G.R.Venkatakrishnan, Page: 1.38]

According to Newton's second law, the inertia torque is proportional to the angular acceleration.

$$T_j(t) \propto \frac{d^2\theta}{dt^2}$$

$$T_j(t) = J \frac{d^2\theta}{dt^2}$$

where J is the moment of inertia ($\text{kg}\cdot\text{m}^2/\text{rad}$), $\theta(t)$ is the angular displacement (rad) and $T_j(t)$ is measured in Newton-meter (N-m).

Damping Torque, $T_b(t)$

When a torque, $T(t)$ is applied to a damping element, B , it experiences an angular velocity and it is shown in figure 1.3.7.

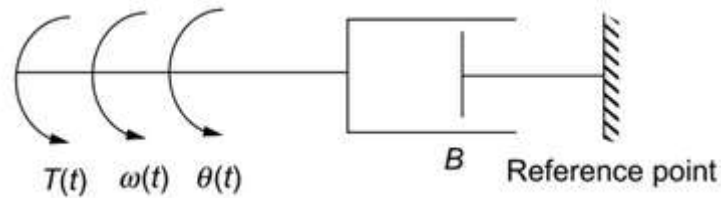

Figure 1.3.7 Mechanical rotational element: Dashpot

[Source: "Control Systems Engineering" by S.Salivahanan, R.Rengaraj, G.R.Venkatakrishnan, Page: 1.38]

The damping torque is proportional to the angular velocity. Therefore,

$$T_b(t) \propto \frac{d\theta}{dt}$$

$$T_b(t) = B \frac{d\theta}{dt}$$

where, B is the viscous friction coefficient ($\text{N}\cdot\text{s}/\text{m}$), $\theta(t)$ is the angular displacement (rad). Damper element with two angular displacements and a single applied torque is shown in figure 1.3.8.

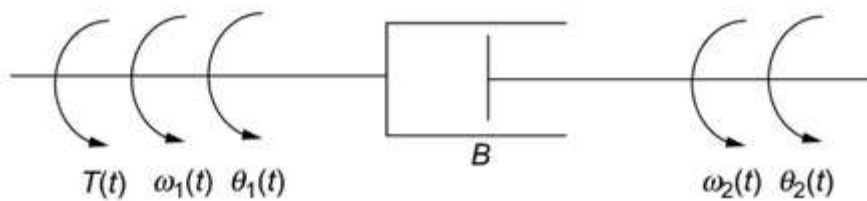

Figure 1.3.8 Mechanical rotational element: Dashpot

[Source: "Control Systems Engineering" by S.Salivahanan, R.Rengaraj, G.R.Venkatakrishnan, Page: 1.39]

$$T_b(t) = B \left(\frac{d\theta_1}{dt} - \frac{d\theta_2}{dt} \right)$$

Here, $T_b(t)$ is measured in Newton-meter.

Torsional/Rotational Spring Torque, $T_k(t)$

When a torque $T(t)$ is applied to a spring element, K , it experiences an angular displacement and it is shown in figure 1.3.9.

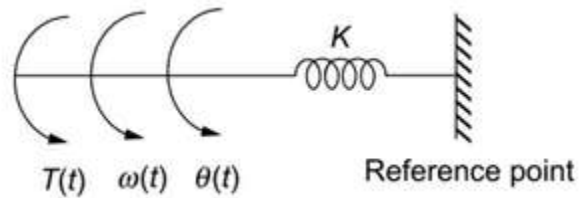

Figure 1.3.9 Mechanical rotational element: Dashpot

[Source: "Control Systems Engineering" by S.Salivahanan, R.Rengaraj, G.R.Venkatakrishnan, Page: 1.39]

According to Hooke's law, spring torque is proportional to the angular displacement.

$$T_k(t) \propto \theta$$

$$T_k(t) = K\theta$$

where, K is the spring constant (N-m/rad).

A spring element with two angular displacements is given in figure 1.3.10.

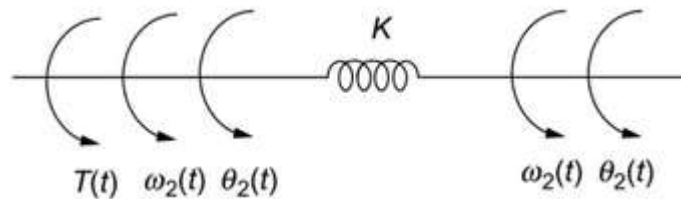

Figure 1.3.10 Mechanical rotational element: Dashpot

[Source: "Control Systems Engineering" by S.Salivahanan, R.Rengaraj, G.R.Venkatakrishnan, Page: 1.40]

$$T_k(t) = K(\theta_1 - \theta_2)$$

Here, $T_k(t)$ is measured in Newton-meter.

According to D'Alembert's principle, "The algebraic sum of the externally applied torques to any body is equal to the algebraic sum of the opposing torques restraining motion produced by the elements present in the body." A simple rotational mechanical system and its free body diagram are shown in figures 1.3.11 (a) and (b) respectively.

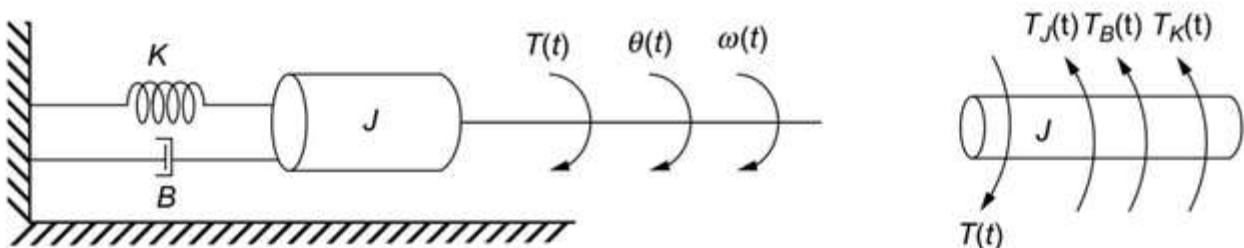

(a) A simple rotational mechanical system

(b) Free body diagram

Figure 1.3.11 Mechanical rotational system and its free body diagram

[Source: "Control Systems Engineering" by S.Salivahanan, R.Rengaraj, G.R.Venkatakrishnan, Page: 1.40]

$$T_j = J \frac{d^2\theta}{dt^2}$$

$$T_b = B \frac{d\theta}{dt}$$

$$T_k = K\theta$$

$$T(t) = T_j + T_b + T_k = J \frac{d^2\theta}{dt^2} + B \frac{d\theta}{dt} + K\theta$$

Translational mechanical system	Rotational mechanical system
Force (F)	Torque (T)
Velocity (v)	Angular velocity (ω)
Displacement (x)	Angular displacement (θ)
Mass (M)	Moment of inertia (J)
Damping coefficient (B)	Rotational damping (B)
Spring constant (K)	Rotational spring constant (K)