

2.2. SHEAR FORCE AND BENDING MOMENT DIAGRAM FOR A CANTILEVER BEAM WITH SINGLE POINT LOAD AT FREE END

The following figure shows a cantilever AB of length L fixed at A and free at B and carrying a point load W at the free end B.

Let F_x = Shear force at X and M_x = Bending moment at X

Take a section X at a distance x from the free end. Consider the right portion of the section.

Shear Force Calculation

The shear force at the section B is equal to the resultant force acting on the right portion

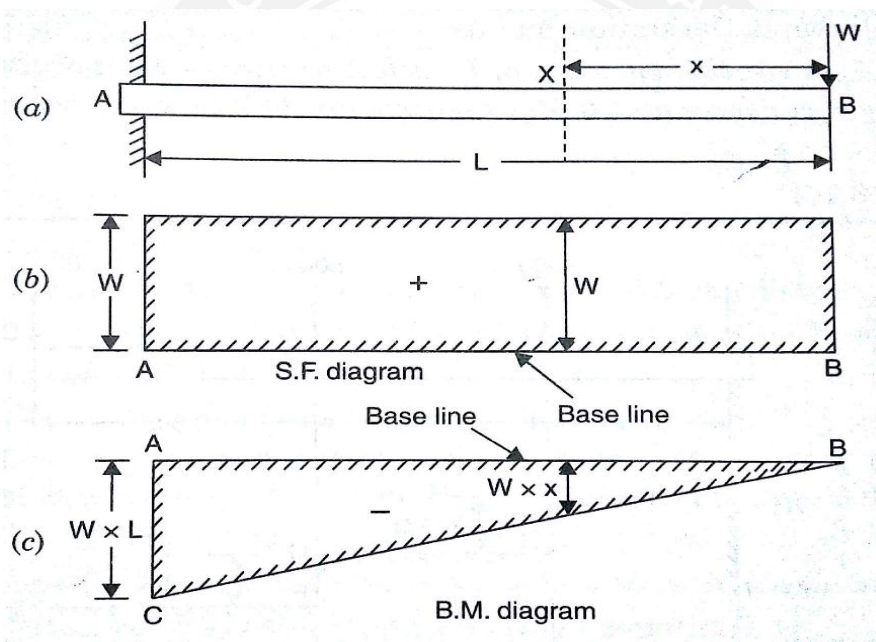

at the given section B as W and it acting downward is considered as positive.

The shear force at this section X-X is equal to the resultant force acting on the right portion at the given section X-X as W and it acting downward is considered as positive.

The shear force will be constant at all section of the cantilever between A and B as there is no load between A and B. The shear force diagram is shown in fig.

SF at B = + W (+ve due to right side downward load)

SF at X-X = +W (Because no load between B and X-X)

SF at A = +W (due to same load as above)

Shear force diagram:

Bending Moment Calculation:

The Bending Moment at the section B is proportional to the distance of the section from the free end as $(W \times 0)$ and it acting clockwise about that section is considered as negative.

The Bending Moment at this section X-X is proportional to the distance of the section from the free end as x as $(W \times x)$ and it acting clockwise about that section is considered as negative.

The Bending Moment at this section fixed end is proportional to the distance of the section from the free end as L as $(W \times L)$ and it acting clockwise about that section is considered as negative. The Bending Moment diagram is shown in fig.

Problem 2.2.1: A cantilever 6m long carries load of 30, 70, 40 and 60 kN at a distance of 0,0.6, 1.5 and 2m respectively from the free end. Draw the SF and BM diagram for the cantilever.

Given Data: shown in figure.

To find: SFD and BMD

Solution:

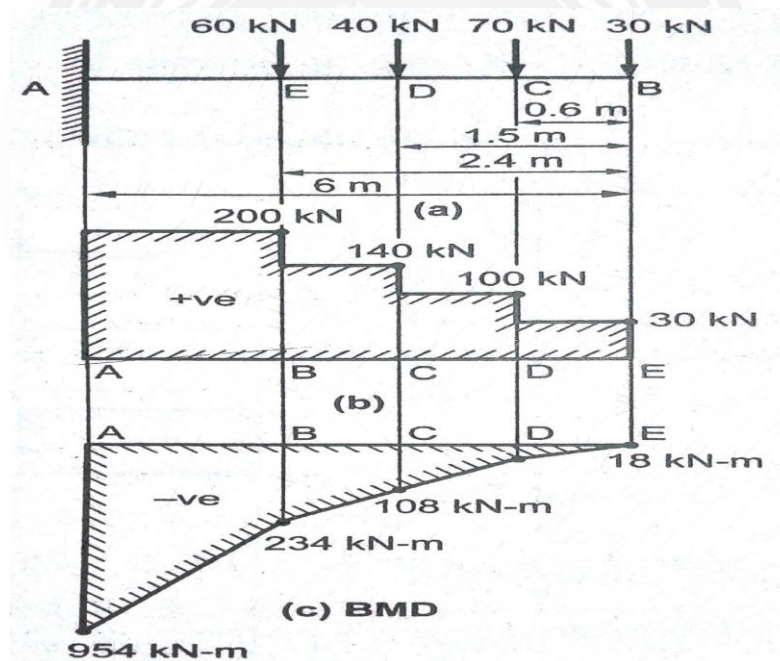

Shear Force

Calculation:

(Sum of vertical forces)

$$\text{SF at B} = +30 \text{ kN}$$

$$\text{SF at C} = +30 + 70 = +100 \text{ kN}$$

$$\text{SF at D} = +30 + 70 + 40 = +140 \text{ kN}$$

$$\text{SF at E} = +30 + 70 + 40 + 60 = +200 \text{ kN}$$

Shear Force Diagram:

Vertical downward point load are drawn as upward vertical line

No load are drawn as horizontal line.

Bending moment Calculation: [Sum of (Vertical force x Acting distance)]

$$\text{BM at B} = -(30 \times 0) \text{ kN} = 0 \text{ kNm}$$

$$\text{BM at C} = -(30 \times 0.6) - (70 \times 0) = -18\text{kNm}$$

$$\text{BM at D} = -(30 \times 1.5) - (70 \times 0.9) - (40 \times 0) = -108\text{kNm}$$

$$\text{BM at E} = -(30 \times 2.4) - (70 \times 1.8) - (40 \times 0.9) - (60 \times 0) = -234\text{kNm}$$

$$\text{BM at A} = -(30 \times 6) - (70 \times 5.4) - (40 \times 4.5) - (60 \times 3.6) = -954\text{ kNm}$$

Bending moment Diagram:

Vertical downward point load are drawn as inclined line. All BM are in negative side.

Result: The SFD and BMD are drawn as shown in fig.

2.2.2. SHEAR FORCE AND BENDING MOMENT DIAGRAM FOR A CANTILEVER BEAM WITH UNIFORMLY DISTRIBUTED LOAD

Consider a cantilever beam of length L fixed at A and carrying a uniformly distributed load of w per unit length over the entire length of the beam.

Take the section X at a distance of ' x ' from the free end B. Here we have consider the right portion of the beam section.

$$\text{Let } F_x = \text{Shear force at X and } M_x = \text{Bending moment at X}$$

Shear Force Calculation:

The shear force at the section X will be equal to the resultant force acting on the right portion up to the section.

$$\text{The resultant force on the right portion} = \text{load} \times \text{distance of right portion} = w \times x$$

The resultant force acting on the right portion acting downward is considered positive.

$$\therefore \text{Shear force at X, } F_x = + w \cdot x$$

The above equation shows that the shear force follows a straight line law.

$$\text{SF at B, when } x = 0 \text{ hence } = + (\text{load} \times \text{distance}) = w \times 0 = + 0$$

$$\text{SF at A, when } x = L \text{ hence } = + (\text{load} \times \text{distance}) = w \times L = + w \cdot L$$

Shear Force Diagram:

When an UDL acting on the beam is indicated in Shear force diagram as an *inclined line*. The shear force diagram shown in fig.

Bending moment Calculation:

The UDL over a section of beam is converted into point load acting at the C.G of the section.

The bending moment will be negative as for the right portion of the section, the moment of the load at x is clockwise.

The bending moment at the section X is given by

$$M_x = -(\text{total load on right portion}) \times (\text{distance of C.G of right portion from X})$$

$$= - (w \cdot x) \times \left(\frac{x}{2}\right) = - w \frac{x^2}{2}$$

From the above eqn. it is clear that B.M. at any section is proportional to the square of the distance from the free end. This follows a parabolic law.

$$\text{BM at B, when } x = 0 \text{ hence } = - \frac{w}{2} \times 0 = 0$$

$$\text{BM at A, when } x = L \text{ hence } = - \frac{w}{2} \times L^2 = - w \cdot \frac{L^2}{2}$$

Bending moment Diagram:

When an UDL acting on the beam is indicated in Bending Moment diagram as an *parabolic curved line*. The Bending Moment diagram shown in fig.

Problem 2.2.3: A cantilever of length 2m carries a UDL of 3 kN/m. Draw the SF and BM diagram.

Given Data: shown in figure.

To find: SFD and BMD

Solution:

Shear Force Calculation: (Sum of vertical forces)

For UDL, it will be converted into point load as (Point load = UDL x load acting distance) and the converted point load acting at its middle means divided by 2

$$\text{SF at B} = + 0 \text{ kN}$$

$$\text{SF at A} = + 0 + (3 \times 2) = + 6 \text{ kN}$$

Shear Force Diagram:

Vertical downward UDL are drawn as inclined line based on sign

No load are drawn as horizontal line.

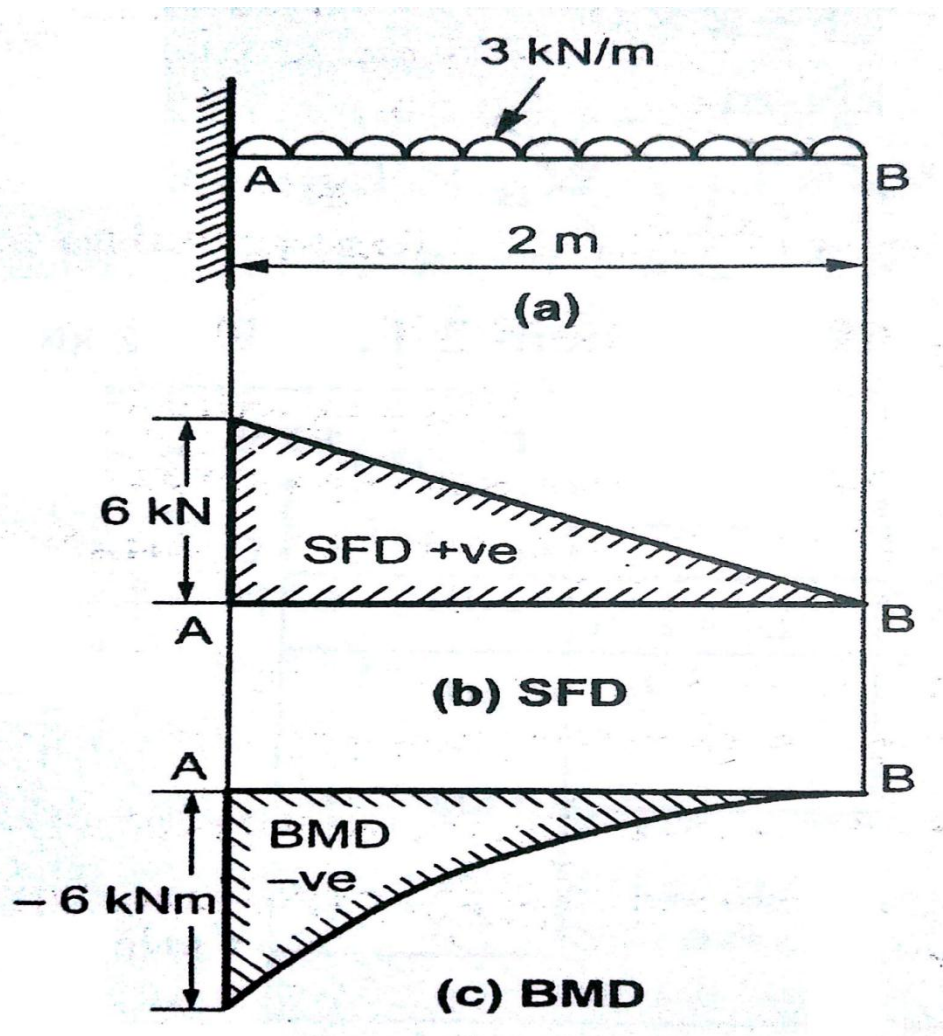

Bending moment Calculation: [Sum of (Vertical force x Distance of load acting from required section)]

For UDL, it will convert into point load and that PL act at its middle

$$\text{BM at B} = -(0 \times 0) \text{ kN} = 0 \text{ kNm}$$

$$\text{BM at C} = -(0 \times 2) - [(3 \times 2) \times \frac{2}{2}] = -6 \text{ kNm}$$

Bending moment Diagram:

Vertical downward UDL are drawn as parabolic curved line based on their sign.

Result: The SFD and BMD are drawn as shown in fig.

Problem 2.3: A cantilever of length 4m carries a UDL of 3 kN/m run over the whole length and two point loads of 4kN and 2.5 kN are placed 1m and 2m respectively from the fixed end. Draw the SF and BM diagram.

Given Data: shown in figure.

To find: SFD and BMD

Solution:

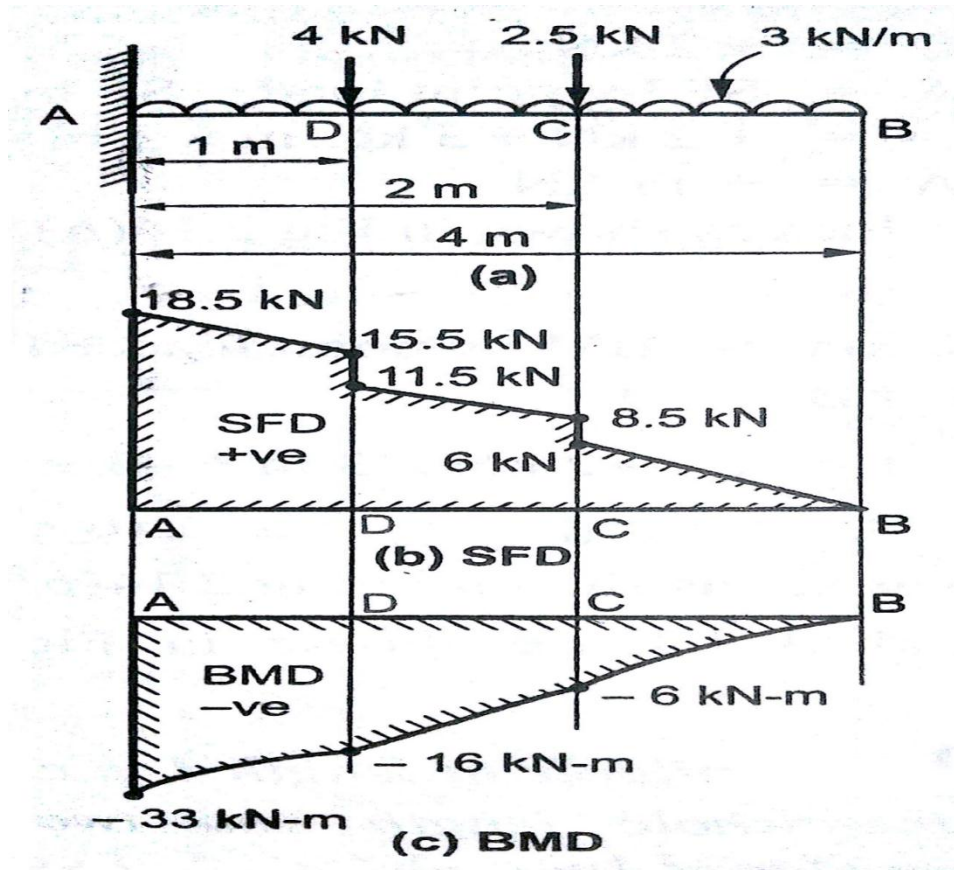

Shear

Force

Calculation: (Sum of vertical forces)

For UDL, it will be converted into point load as (Point load = UDL x load acting distance) and the converted point load acting at its middle means divided by 2

$$\text{SF at B} = + 0 \text{ kN}$$

$$\text{SF at C} = + 0 + 2.5 + (3 \times 2) = + 8.5 \text{ kN}$$

When point load and UDL acting at a particular point, first we have not consider Point Load and next consider point load to find shear force

$$\text{SF at D} = + 3 + 2 + (3 \times 1.5) = + 9.5 \text{ kN} \quad (\text{Without consider PL})$$

$$\text{SF at D} = + 3 + 2 + 2 + (3 \times 1.5) = + 11.5 \text{ kN} \quad (\text{With consider PL})$$

$$\text{SF at A} = + 0 + 2.5 + 4 + (3 \times 4) = + 18.5 \text{ kN}$$

Shear Force Diagram:

Vertical downward point load are drawn as vertical line based on sign

Vertical downward UDL are drawn as inclined line based on sign

Bending moment Calculation: [Sum of (Vertical force x Distance of load acting from required section)]

For UDL, it will convert into point load and that PL act at its middle

$$\text{BM at B} = -(0 \times 0) = 0 \text{ kNm}$$

$$\text{BM at C} = -(0 \times 2) - (2.5 \times 0) - [(3 \times 2) \times \frac{2}{2}] = -6 \text{ kNm}$$

$$\text{BM at D} = -(0 \times 3) - (2.5 \times 1) - (4 \times 0) - [(3 \times 3) \times \frac{3}{2}] = -16 \text{ kNm}$$

$$\text{BM at A} = -(0 \times 4) - (2.5 \times 2) - (4 \times 1) - [(3 \times 4) \times \frac{4}{2}] = -33 \text{ kNm}$$

Bending moment Diagram:

Vertical downward UDL are drawn as parabolic curved line based on their sign.

Result:

The SFD and BMD are drawn as shown in fig.

Problem 2.4: A cantilever of length 5m carries a UDL of 3 kN/m run over the length of 1.5m start from 1.5m from fixed end and two point load 2kN acting at 1.5m and 3m respectively from fixed end and another point load 3kN acting at the free end. Draw the SF and BM diagram.

Given Data: shown in figure.

To find: SFD and BMD

Solution:

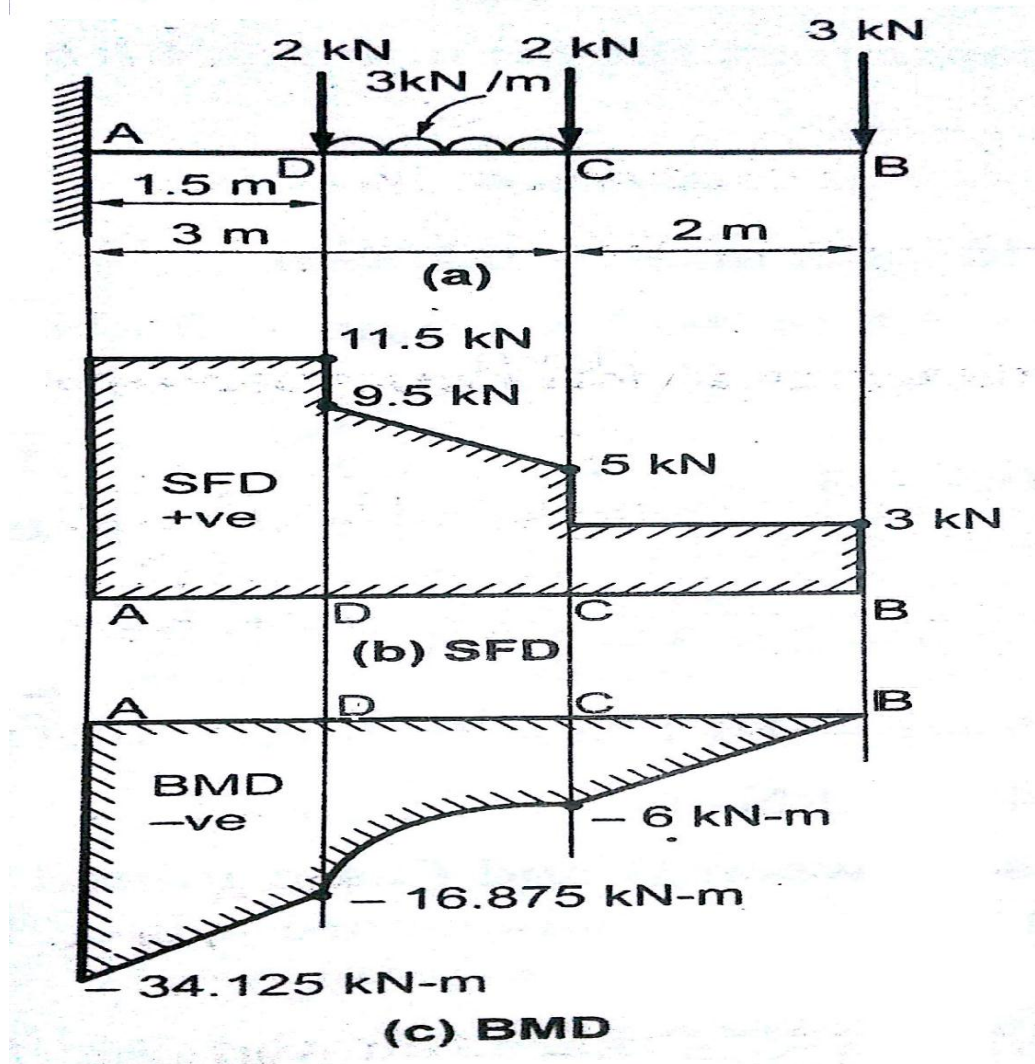

Shear Force Calculation: (Sum of vertical forces)

For UDL, it will be converted into point load as (Point load = UDL x load acting distance) and the converted point load acting at its middle means divided by 2

$$\text{SF at B} = + 3\text{kN}$$

$$\text{SF at C} = + 3 + 2 = + 5 \text{ kN}$$

When point load and UDL acting at a particular point, first we have not consider Point Load and next consider point load to find shear force

$$\text{SF at D} = + 3 + 2 + (3 \times 1.5) = + 9.5 \text{ kN (Without consider PL)}$$

$$\text{SF at D} = + 3 + 2 + 2 + (3 \times 1.5) = + 11.5 \text{ kN (With consider PL)}$$

$$\text{SF at A} = + 3 + 2 + 2 + (3 \times 1.5) = + 11.5 \text{ kN}$$

Shear Force Diagram:

Vertical downward point load are drawn as vertical line based on sign.

Vertical downward UDL are drawn as inclined line based on sign.

No load are drawn as horizontal line.

Bending moment Calculation: [Sum of (Vertical force x Distance of load acting from required section)]

For UDL, it will convert into point load and that PL act at its middle

$$\text{BM at B} = - (3 \times 0) = 0 \text{ kNm}$$

$$\text{BM at C} = - (3 \times 2) - (2 \times 0) = - 6 \text{ kNm}$$

$$\text{BM at D} = - (3 \times 3.5) - (2 \times 1.5) - (2 \times 0) - [(3 \times 1.5) \times \frac{1.5}{2}] = - 16.875\text{kNm}$$

$$\text{BM at A} = - (3 \times 5) - (2 \times 3) - (2 \times 1.5) - [(3 \times 1.5) \times (\frac{1.5}{2} + 1.5)] = - 34.125\text{kNm}$$

Bending moment Diagram:

Vertical downward PL are drawn as inclined line based on their sign. Vertical downward UDL are drawn as parabolic curved line based on their sign.

Result:

The SFD and BMD are drawn as shown in fig.

2.10. SHEAR FORCE AND BENDING MOMENT DIAGRAM FOR A CANTILEVER BEAM WITH UNIFORMLY VARYING LOAD

Consider a cantilever beam of length L fixed at A and carrying a uniformly varying load from zero at the free end and to w per unit length at the fixed end of beam.

Take the section X at a distance of 'x' from the free end B. Here we have consider the right portion of the beam section.

Let F_x = Shear force at X and M_x = Bending moment at X

Shear Force Calculation:

Let us first find the rate of loading at the section X. The rate of loading is zero at B and is 'w' per meter run at A. This means that rate of loading for a length L is w per unit length.

Hence rate of loading for a length of $x = \frac{w}{L} \times x$ per unit length. Which is equal to the load acting at X = CX = $\frac{w}{L} \times x$

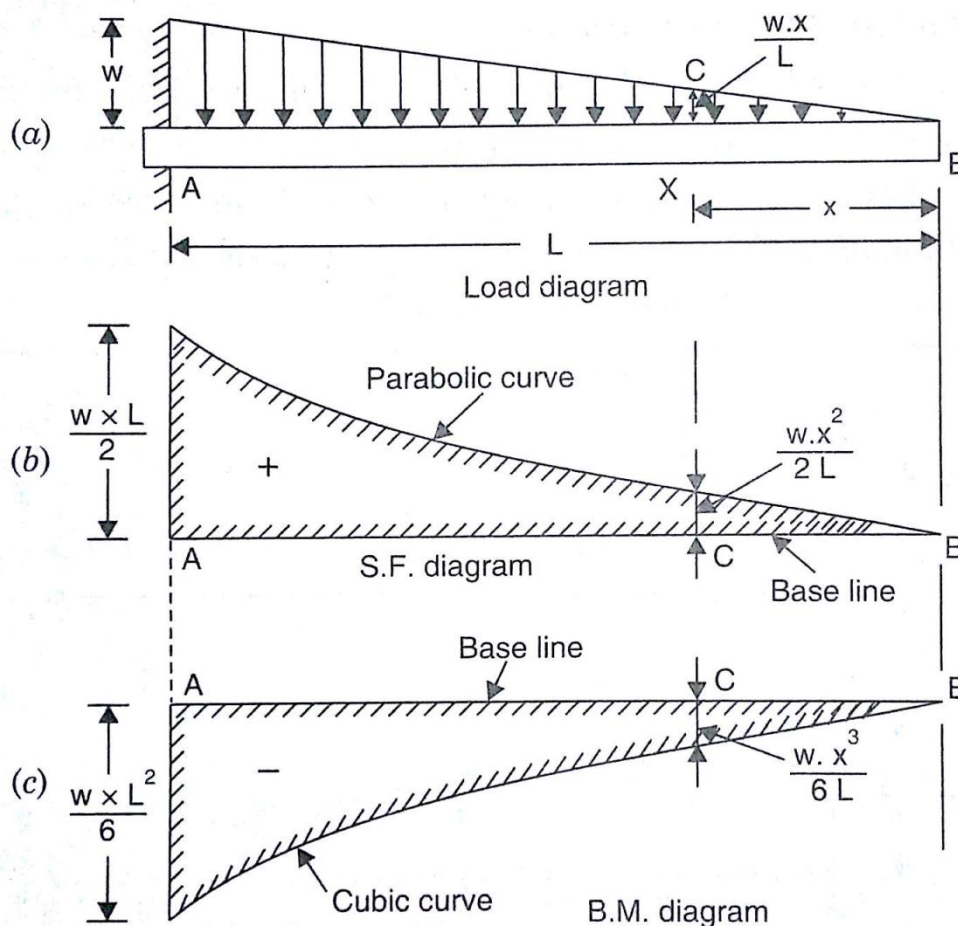

The resultant force acting on the right portion acting downward is considered positive.

The shear force at the section X at a distance x from free end is given by

$$\begin{aligned}
 F_x &= +(\text{Total load on the cantilever for a length } x \text{ from the free end B}) \\
 &= +(\text{Area of triangle BCX}) \\
 &= +\left(\frac{1}{2} \times XB \times XC\right) \\
 &= +\frac{1}{2} \times x \times \left(\frac{w}{L} \times x\right) = +w \cdot \frac{x^2}{2L} \quad \left(\because XB = x, XC = \frac{w}{L} \times x\right)
 \end{aligned}$$

From the above eqn. shows that the SF varies according to the parabolic law.

$$\text{SF at B, when } x = 0 \text{ hence } = + w \cdot \frac{0^2}{2L} = 0$$

$$\text{SF at A, when } x = L \text{ hence } = + w \cdot \frac{L^2}{2L} = + \frac{wL}{2}$$

Shear Force Diagram:

When an UVL acting on the beam is indicated in Shear force diagram as an *Parabolic curved line*. The shear force diagram shown in fig.

Bending moment Calculation:

The UVL over a section of beam is converted into point load acting at the C.G of the section.

The bending moment will be negative as for the right portion of the section, the moment of the load at x is clockwise about the section.

The bending moment at the section X is given by

$$\begin{aligned} M_x &= -(\text{total load on right portion}) \times (\text{Distance of the load from X}) \\ &= -(\text{Area of triangle BCX}) \times (\text{Distance of C.G of triangle from X}) \\ &= -\left(w \cdot \frac{x^2}{2L}\right) \times \left(\frac{x}{3}\right) = -\frac{wx^3}{6L} \end{aligned}$$

From the above eqn. it is clear that B.M. at any section is proportional to the cube of the distance from the free end. This follows a cubic law.

$$\text{BM at B, when } x = 0 \text{ hence } = -\frac{w \times 0}{6L} = 0$$

$$\text{BM at A, when } x = L \text{ hence } = -\frac{w \times L^3}{6L} = -w \cdot \frac{L^2}{6}$$

Bending moment Diagram:

When an UDL acting on the beam is indicated in Bending Moment diagram as an *cubic curved line*. The Bending Moment diagram shown in fig.

Problem 2.5: A cantilever of length 4m carries a gradually increasing load, zero at the free end to 2kN/m at the fixed end. Draw the SF and BM diagrams for the cantilever.

Given Data: shown in figure.

To find: SFD and BMD

Solution:

Shear Force Calculation: (Sum of vertical forces)

For UVL, it will be converted into point load as (Point load = Area of triangle = $\frac{1}{2} \times$ UVL \times load acting distance) and the converted point load acting distance at its $\frac{l}{3}$ from the higher load end.

$$\text{SF at B} = + 0 \text{ kN}$$

$$\text{SF at A} = + 0 + \left(\frac{1}{2} \times 2 \times 4\right) = + 4 \text{ kN}$$

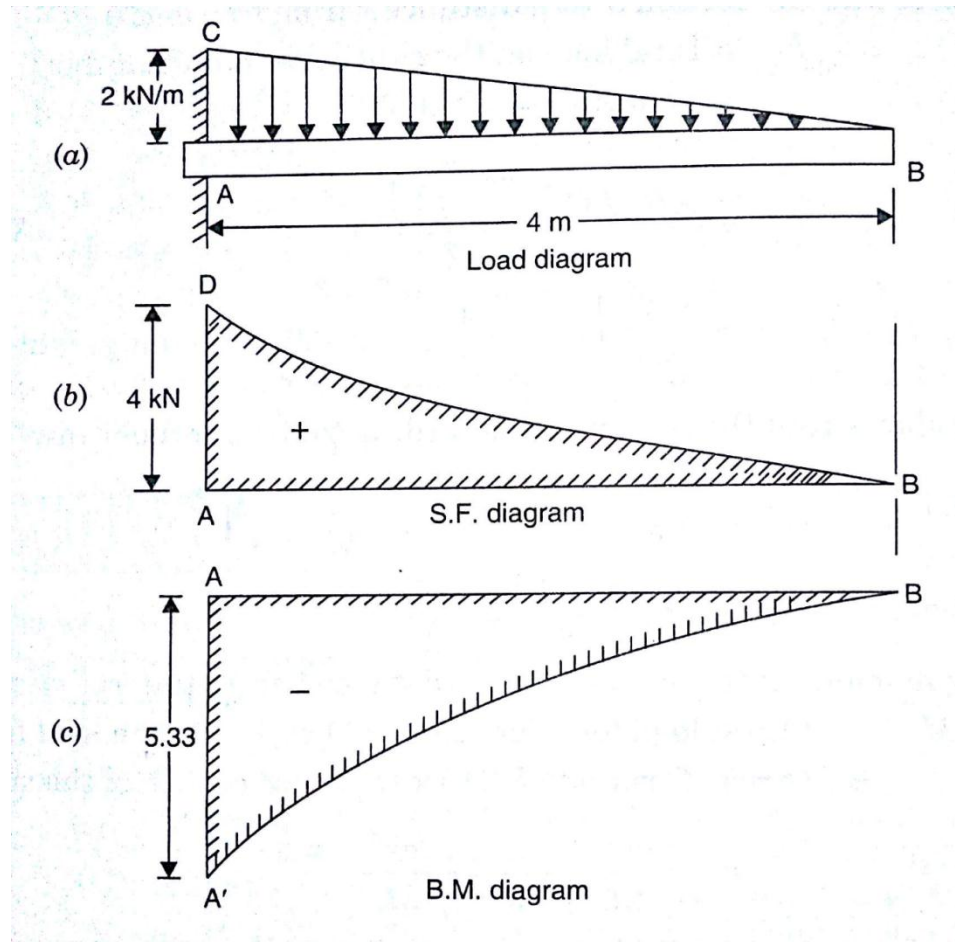

Shear Force Diagram:

Downward UVL are drawn as parabolic curved line based on sign.

Bending moment Calculation: [Sum of (Vertical force \times Distance of load acting from required section)]

For UVL, it will convert into point load and that PL act at its $\frac{l}{3}$ from the higher load end.

$$\text{BM at B} = - (0 \times 0) = 0 \text{ kNm}$$

$$\text{BM at A} = - (0 \times 4) - \left[\left(\frac{1}{2} \times 2 \times 4\right) \times \frac{4}{3}\right] = - 5.33 \text{ kNm}$$

Bending moment Diagram:

Vertical downward UVL are drawn as cubic curved line based on their sign.

Result: The SFD and BMD are drawn as shown in fig.