

2.4 MEDIUM TRANSMISSION LINES

In short transmission line calculations, the effects of the line capacitance are neglected because such lines have smaller lengths and transmit power at relatively low voltages (< 20 kV). However, as the length and voltage of the line increase, the capacitance gradually becomes of greater importance.

Since medium transmission lines have sufficient length (50-150 km) and usually operate at voltages greater than 20 kV, the effects of capacitance cannot be neglected. Therefore, in order to obtain reasonable accuracy in medium transmission line calculations, the line capacitance must be taken into consideration.

The capacitance is uniformly distributed over the entire length of the line. However, in order to make the calculations simple, the line capacitance is assumed to be lumped or concentrated in the form of capacitors shunted across the line at one or more points. Such a treatment of localising the line capacitance gives reasonably accurate results. The most commonly used methods (known as localised capacitance methods) for the solution of medium transmission lines are :

- (i) End condenser method
- (ii) Nominal T method
- (iii) Nominal π method.

Although the above methods are used for obtaining the performance calculations of medium lines, they can also be used for short lines if their line capacitance is given in a particular problem.

i)End Condenser Method

In this method, the capacitance of the line is lumped or concentrated at the receiving or load end as shown in Fig. This method of localising the line capacitance at the load end overestimates the effects of capacitance. In Fig, one phase of the 3-phase transmission line is shown as it is more convenient to work in phase instead of line-to-line values.

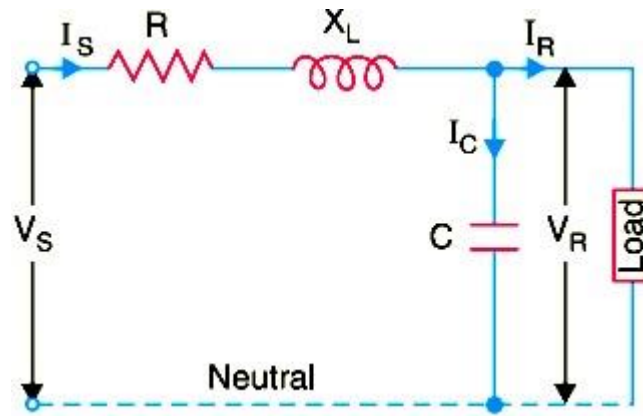

Figure 2.4.1 Equivalent Circuit End Condenser Method

[Source: "Principles of Power System" by V.K.Mehta Page: 253]

Let

I_R = load current per phase

R = resistance per phase

X_L = inductive reactance per phase

C = capacitance per phase

$\cos \phi_R$ = receiving end power factor (lagging)

V_S = sending end voltage per phase

The phasor diagram for the circuit is shown in Fig, Taking the receiving end voltage V_R as the reference phasor,

we have,

$$V_R = V_R + j 0$$

$$\text{Load current, } I_R = I_R (\cos \phi_R - j \sin \phi_R)$$

$$\text{Capacitive current, } I_C = j V_R \omega C = j 2 \pi f C V_R$$

The sending end current I_S is the phasor sum of load current I_R and capacitive current I_C i.e.,

$$\begin{aligned} I_S &= I_R + I_C \\ &= I_R (\cos \phi_R - j \sin \phi_R) + j 2 \pi f C V_R \\ &= I_R \cos \phi_R + j (-I_R \sin \phi_R + 2 \pi f C V_R) \end{aligned}$$

$$\text{Voltage drop/phase} = I_S Z = I_S (R + j X_L)$$

$$\text{Sending end voltage, } V_S = V_R + I_S Z = V_R + I_S (R + j X_L)$$

$$\% \text{ Voltage regulation} = \frac{V_S - V_R}{V_R} \times 100$$

ii) Nominal T Method

In this method, the whole line capacitance is assumed to be concentrated at the middle point of the line and half the line resistance and reactance are lumped on its either side as shown in Fig. Therefore, in this arrangement, full charging current flows over half the line. In Fig. one phase of 3-phase transmission line is shown as it is advantageous to work in phase instead of line-to-line values.

Let

I_R = load current per phase

R = resistance per phase

X_L = inductive reactance per phase

C = capacitance per phase

$\cos \phi_R$ = receiving end power factor (lagging)

V_S = sending end voltage/phase

V_1 = voltage across capacitor C

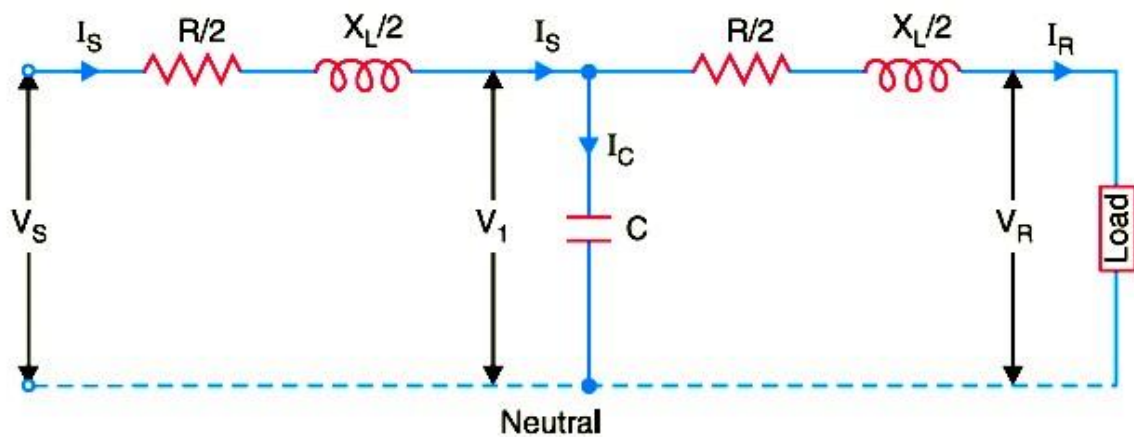

Figure 2.4.2 Equivalent Circuit Nominal - T Method

[Source: "Principles of Power System" by V.K.Mehta Page: 243]

The phasor diagram for the circuit is shown in Fig.2.4.3, Taking the receiving end voltage V_R as the reference phasor, we have,

$$\text{Receiving end voltage, } \vec{V}_R = V_R + j0$$

$$\text{Load current, } \vec{I}_R = I_R (\cos \phi_R - j \sin \phi_R)$$

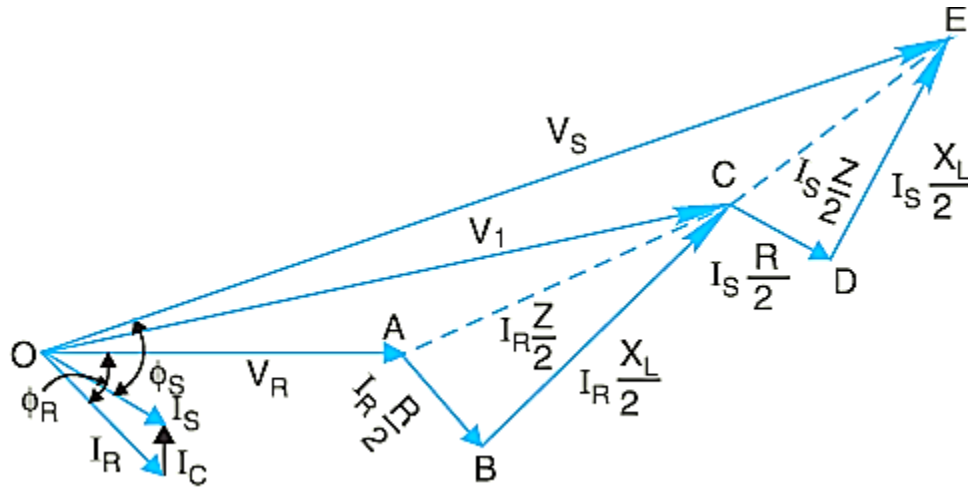

Figure 2.4.3 Phasor Diagram Nominal - T Method

[Source: "Principles of Power System" by V.K.Mehta Page: 243]

$$\begin{aligned}
 \text{Voltage across } C, \quad \vec{V}_1 &= \vec{V}_R + \vec{I}_R \vec{Z} / 2 \\
 &= V_R + I_R (\cos \phi_R - j \sin \phi_R) \left(\frac{R}{2} + j \frac{X_L}{2} \right) \\
 \text{Capacitive current,} \quad \vec{I}_C &= j \omega C \vec{V}_1 = j 2\pi f C \vec{V}_1 \\
 \text{Sending end current,} \quad \vec{I}_S &= \vec{I}_R + \vec{I}_C \\
 \text{Sending end voltage,} \quad \vec{V}_S &= \vec{V}_1 + \vec{I}_S \frac{\vec{Z}}{2} = \vec{V}_1 + \vec{I}_S \left(\frac{R}{2} + j \frac{X_L}{2} \right)
 \end{aligned}$$

iii) Nominal π Method

In this method, capacitance of each conductor (i.e., line to neutral) is divided into two halves; one half being lumped at the sending end and the other half at the receiving end as shown in Fig. It is obvious that capacitance at the sending end has no effect on the line drop. However, its charging current must be added to line current in order to obtain the total sending end current.

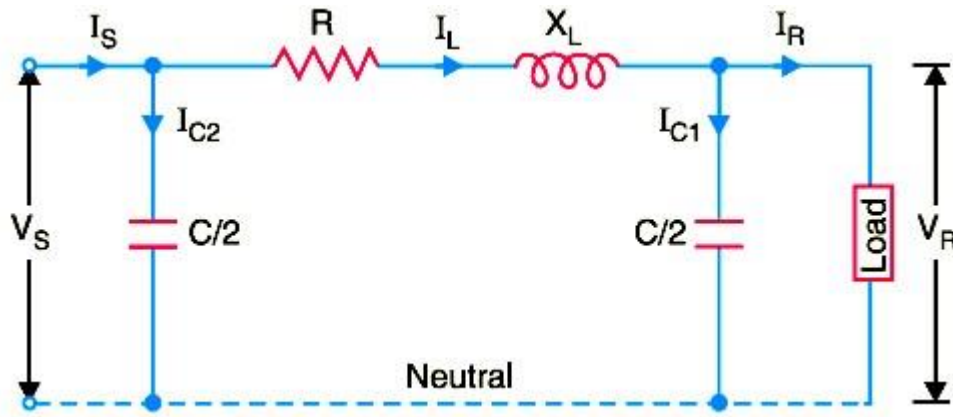

Figure 2.4.4 Equivalent Circuit Nominal - π Method

[Source: "Principles of Power System" by V.K.Mehta Page: 246]

Let

I_R = load current per phase

R = resistance per phase

X_L = inductive reactance per phase

C = capacitance per phase

$\cos \phi_R$ = receiving end power factor (lagging)

V_S = sending end voltage per phase

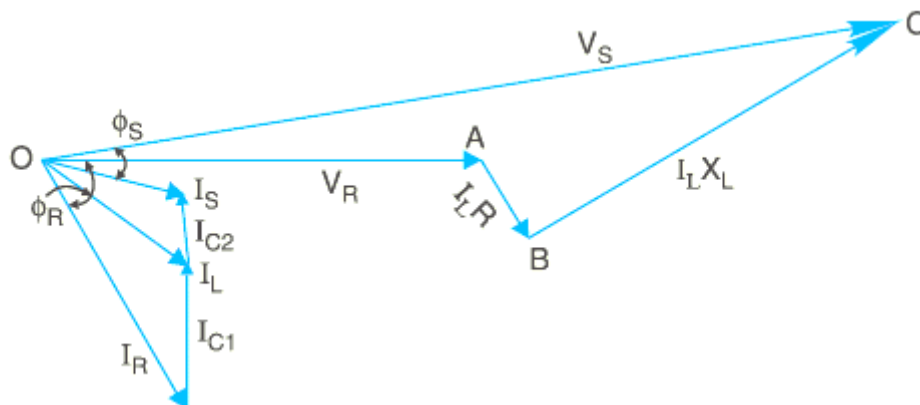

Figure 2.4.5 Phasor Diagram Nominal - π Method

[Source: "Principles of Power System" by V.K.Mehta Page: 243]

The phasor diagram for the circuit is shown in Fig 2.4.5 Taking the receiving end voltage as the reference phasor, we have,

$$\vec{V}_R = V_R + j0$$

Load current, $\vec{I}_R = I_R (\cos \phi_R - j \sin \phi_R)$

Charging current at load end is

$$\vec{I}_{C1} = j \omega (C/2) \vec{V}_R = j \pi f C \vec{V}_R$$

Line current, $\vec{I}_L = \vec{I}_R + \vec{I}_{C1}$

Sending end voltage, $\vec{V}_S = \vec{V}_R + \vec{I}_L \vec{Z} = \vec{V}_R + \vec{I}_L (R + jX_L)$

Charging current at the sending end is

$$\vec{I}_{C2} = j \omega (C/2) \vec{V}_S = j \pi f C \vec{V}_S$$

∴ Sending end current, $\vec{I}_S = \vec{I}_L + \vec{I}_{C2}$

Problem 1

Determine the efficiency and regulation of a 3-phase, 100 km, 50 Hz transmission line delivering 20 MW at a p.f. of 0.8 lagging and 66 kV to a balanced load. The conductors are of copper, each having resistance 0.1 ohm per km, 1.5 cm outside dia, spaced equilaterally 2 metres between centres. Neglect leakage and use (i) nominal- T , and (ii) nominal- π method.

Solution:

Total resistance of line $100 \times 0.1 = 10$ ohms.

$$\begin{aligned} \text{The inductance of the line} &= 2 \times 10^{-7} \times 100 \times 1000 \ln\left(\frac{200}{0.75}\right) \\ &= 11.17 \times 10^{-2} \text{ H} \end{aligned}$$

$$\therefore \text{Inductive reactance} = 314 \times 11.17 \times 10^{-2} = 35.1 \text{ ohm}$$

$$\begin{aligned} \text{The capacitance/phase} &= \frac{2\pi \times 8.854 \times 10^{-12}}{\ln\left(\frac{200}{0.75}\right)} \times 100 \times 1000 \\ &= 9.954 \times 10^{-7} \\ &= 0.9954 \mu\text{F}. \end{aligned}$$

Nominal-T method: The nominal- T circuit for the problem is given below:

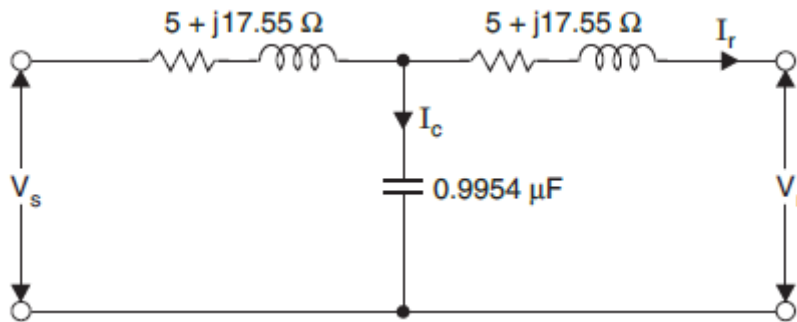
Figure 2.4.6 Nominal - T Method

[Source: "Electrical Power Systems" by C.L.Wadhwa Page: 73]

$$I_r = \frac{20 \times 1000}{\sqrt{3} \times 66 \times 0.8} = 218.68 \text{ amps}$$

$$V_r = \frac{66 \times 1000}{\sqrt{3}} = 38104 \text{ volts}$$

Taking I_r as the reference, the voltage across the condenser will be

$$\begin{aligned} V_c &= (38104 \times 0.8 + 218.68 \times 5) + j(38104 \times 0.6 + 218.68 \times 17.55) \\ &= 31576 + j26700 \end{aligned}$$

The current $I_c = j\omega CV_c = j314(31576 + j26700) \times 0.9954 \times 10^{-6}$
 $= j9.87 - 8.34$

$$\begin{aligned} \therefore I_s &= 218.68 + j9.87 - 8.34 = 210.34 + j9.87 \\ &= 210.57 \text{ amps} \end{aligned}$$

$$\begin{aligned} \therefore V_s &= V_c + I_s \frac{Z}{2} \\ &= 31576 + j26700 + (210.34 + j9.87)(5 + j17.53) \\ &= 31576 + 1051 - 173 + j26700 + j3691 + j49.35 \\ &= 32454 + j30440 \end{aligned}$$

$$\therefore |V_s| = 44495 \text{ volts}$$

The no load receiving end voltage will be

$$\frac{|V_s|(-j3199)}{5 + j17.55 - j3199} = \frac{44495(-j3199)}{5 - j3181} = 44746 \text{ volts}$$

$$\therefore \% \text{ regulation} = \frac{44746 - 38104}{38104} \times 100 = 17.4\%. \quad \text{Ans.}$$

To determine η we evaluate transmission line losses as follows:

$$3[218.68^2 \times 5 + 210.57^2 \times 5] = 1382409 \text{ watts} = 1.3824 \text{ MW}$$

$$\therefore \% \eta = \frac{20}{20 + 1.3824} \times 100 = 93.5\%. \quad \text{Ans.}$$

Nominal- π method: The nominal- π circuit for the problem is as follows:

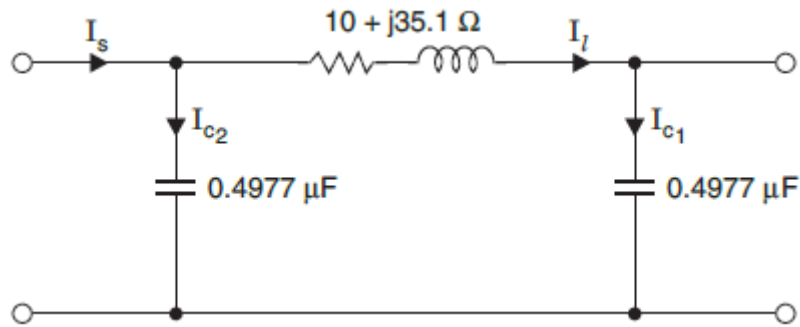

Figure 2.4.7 Nominal - π Method

[Source: "Electrical Power Systems" by C.L.Wadhwa Page: 74]

For nominal- π it is preferable to take receiving end voltage as the reference phasor. The current $I_r = 218.68 (0.8 - j0.6)$.

Current $I_{c1} = j\omega CV_r = j314 \times 0.4977 \times 10^{-6} \times 38104 = j5.95$ amp

$$I_l = I_r + I_{c1} = 174.94 - j131.20 + j5.95 = 174.94 - j125.25$$

$$\begin{aligned} \therefore V_s &= V_r + I_l Z = 38104 + (174.94 - j125.25)(10 + j35.1) \\ &= 38104 + 1749.4 - j1252.5 + j6140 + 4396 \\ &= 44249 + j4886 \text{ volts} \end{aligned}$$

$$|V_s| = 44518 \text{ volts}$$

The no load receiving end voltage will be

$$\begin{aligned} \frac{44518 (-j6398)}{10 + j35.1 - j6398} &= 44762 \text{ volts} \\ \% \text{ voltage regulation} &= \frac{44762 - 38104}{38104} \times 100 \\ &= 17.47\% \end{aligned}$$

The line current $I_l = 215.15$

$$\therefore \text{Loss} = 3 \times 215.152 \times 10 = 1.388 \text{ MW}$$

$$\begin{aligned} \therefore \% \eta &= \frac{20}{21.388} \times 100 \\ &= 93.5\%. \text{ Ans.} \end{aligned}$$