

1.5 FULL WAVE BRIDGE RECTIFIER.

A Full wave rectifier is a circuit arrangement which makes use of both half cycles of input alternating current (AC) and convert them to direct current (DC). In our tutorial on **half wave rectifiers**, we have seen that a half wave rectifier makes use of only one half cycle of the input alternating current. Thus a full wave rectifier is much more efficient (double+) than a half wave rectifier. This process of converting both half cycles of the input supply (alternating current) to direct current (DC) is termed full wave rectification.

Full wave rectifier can be constructed in 2 ways. The first method makes use of a center tapped transformer and 2 diodes. This arrangement is known as **Center Tapped Full Wave**

Rectifier. The second method uses a normal transformer with 4 diodes arranged as a bridge. This arrangement is known as a Bridge Rectifier.

Full Wave Rectifier Theory

To understand full wave bridge rectifier theory perfectly, you need to learn half wave rectifier first. In the tutorial of half wave rectifier we have clearly explained the basic working of a rectifier. In addition we have also explained the theory behind a p n junction and the characteristics of a p n junction diode.

Full Wave Rectifier Working & Operation

The working & operation of a full wave bridge rectifier is pretty simple. The circuit diagrams and wave forms we have given below will help you understand the operation of a bridge rectifier perfectly. In the circuit diagram, 4 diodes are arranged in the form of a bridge. The transformer secondary is connected to two diametrically opposite points of the bridge at points A & C. The load resistance R_L is connected to bridge through points B and D.

During the first half cycle

During first half cycle of the input voltage, the upper end of the transformer secondary winding is positive with respect to the lower end. Thus during the first half cycle diodes D1 and D3 are forward biased and current flows through arm AB, enters the load resistance R_L , and returns back flowing through arm DC.

During this half of each input cycle, the diodes D2 and D4 are reverse biased and current is not allowed to flow in arms AD and BC. The flow of current is indicated by solid arrows in the figure above. We have developed another diagram below to help you understand the current flow quickly. See the diagram below – the green arrows indicate beginning of current flow from source (transformer secondary) to the load resistance. The red arrows indicate return path of current from load resistance to the source, thus completing the circuit.

Full Wave Bridge Rectifier – Circuit Diagram with Input and Output Wave Forms

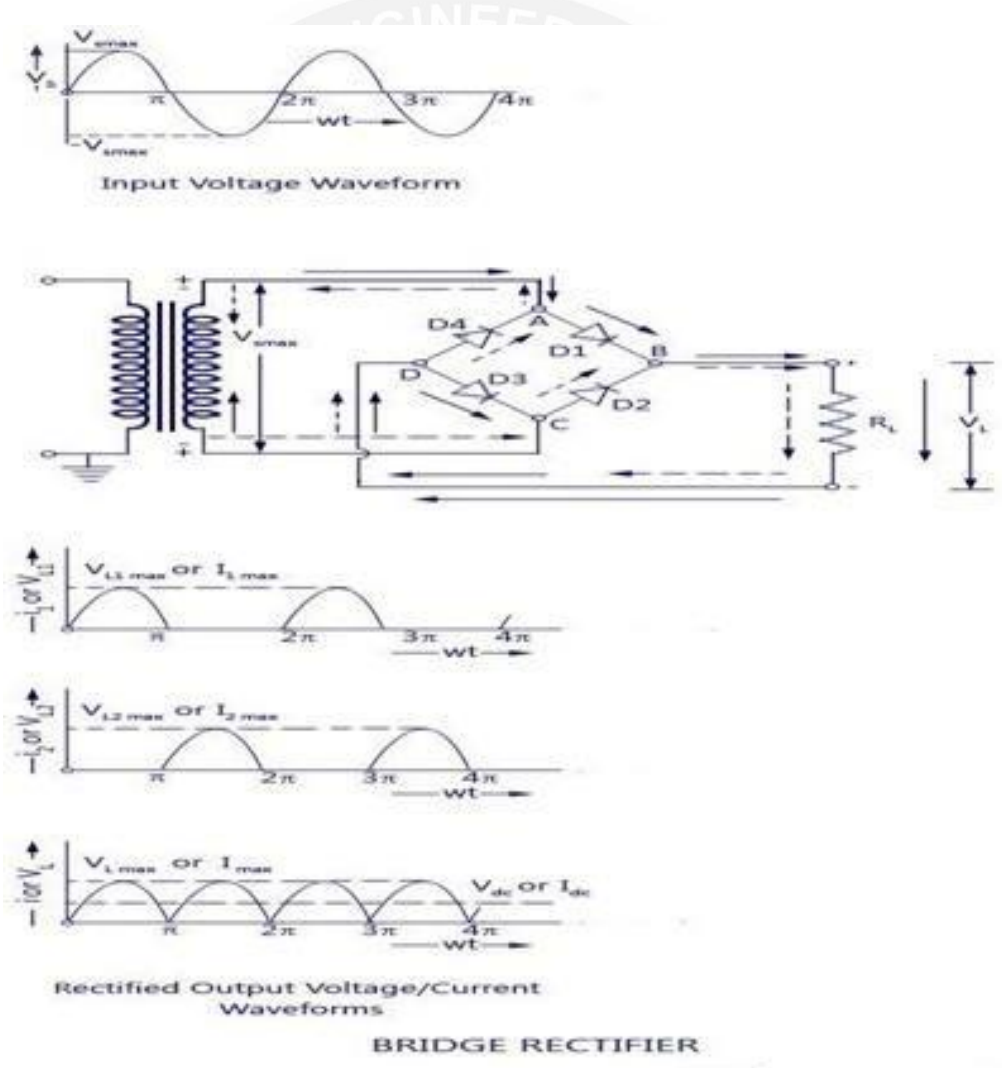

Figure: 1.5.1 Flow of current in Bridge Rectifier

[Source: "Electronic devices and circuits" by "Balbir Kumar, Shail.B.Jain, and Page: 271]

During the second half cycle

During second half cycle of the input voltage, the lower end of the transformer secondary winding is positive with respect to the upper end. Thus diodes D_2 and D_4 become forward biased and current flows through arm CB, enters the load resistance R_L , and returns back to the source flowing through arm DA. Flow of current has been shown by dotted arrows in the figure. Thus the direction of flow of current through the load resistance R_L remains the same during both half cycles of the input supply voltage. See the diagram below – the green arrows indicate beginning of current flow from source (transformer secondary) to the load resistance. The red arrows indicate return path of current from load resistance to the source, thus completing the circuit.

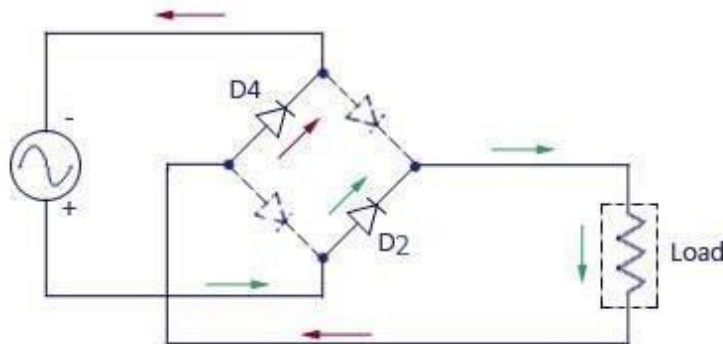

Figure: 1.5.2 Full Wave Bridge Rectifier

[Source: "Electronic devices and circuits" by "Balbir Kumar, Shail.B.Jain, and Page: 271]