

**CS8601 –MOBILE COMPUTING****UNIT 1****INTRODUCTION****1.6. Time Division Multiple Access [TDMA]:**

A more flexible multiplexing scheme for typical mobile communications is time division multiplexing (TDM). Compared to FDMA, time division multiple access (TDMA) offers a much more flexible scheme, which comprises all technologies that allocate certain time slots for communication. Now synchronization between sender and receiver has to be achieved in the time domain. Again this can be done by using a fixed pattern similar to FDMA techniques, i.e., allocating a certain time slot for a channel, or by using a dynamic allocation scheme.

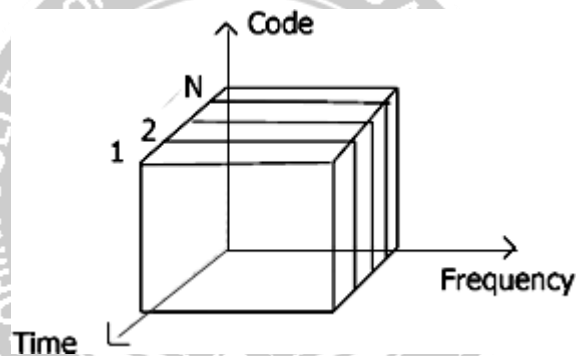

Listening to different frequencies at the same time is quite difficult, but listening to many channels separated in time at the same frequency is simple. Fixed schemes do not need identification, but are not as flexible considering varying bandwidth requirements.

**Fixed TDM**

The simplest algorithm for using TDM is allocating time slots for channels in a fixed pattern. This results in a fixed bandwidth and is the typical solution for wireless phone systems. MAC is quite simple, as the only crucial factor is accessing the reserved time slot at the right moment. If this synchronization is assured, each mobile station knows its turn and no interference will happen. The fixed pattern can be assigned by the base station, where competition between different mobile stations that want to access the medium is solved.

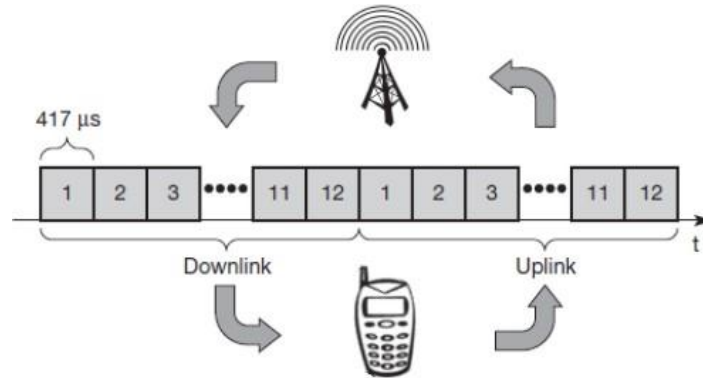

The above figure shows how these fixed TDM patterns are used to implement multiple access and a duplex channel between a base station and mobile station. Assigning different slots for uplink and downlink using the same frequency is called **time division duplex (TDD)**. As shown in the figure, the base station uses one out of 12 slots for the downlink, whereas the mobile station uses one out of 12 different slots for the uplink. Uplink and downlink are separated in time. Up to 12 different mobile stations can use the same frequency without interference using this scheme. Each connection is allotted its own up- and downlink pair. This general scheme still wastes a lot of bandwidth. It is too static, too inflexible for data communication. In this case, connectionless, demand-oriented TDMA schemes can be used.

### Classical Aloha

In this scheme, TDM is applied without controlling medium access. Here each station can access the medium at any time as shown below:

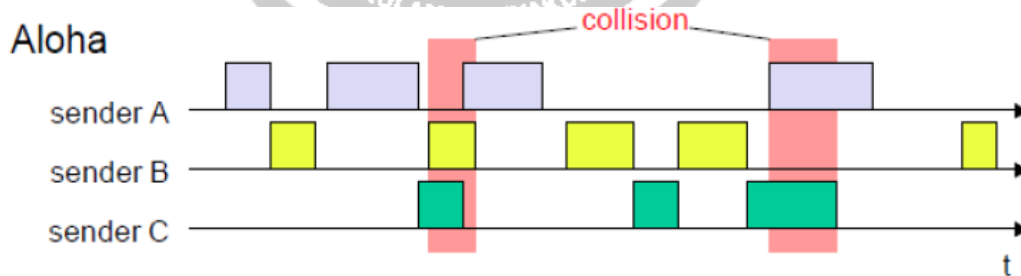

This is a random access scheme, without a central arbiter controlling access and without coordination among the stations. If two or more stations access the medium at the same time, a **collision** occurs and the transmitted data is destroyed. Resolving this problem is left to higher layers (e.g., retransmission of data). The simple Aloha works fine for a light load and does not require any complicated access mechanisms.

### Slotted Aloha

The first refinement of the classical Aloha scheme is provided by the introduction of

timeslots (**slotted Aloha**). In this case, all senders have to be **synchronized**, transmission can only start at the beginning of a **time slot** as shown below.

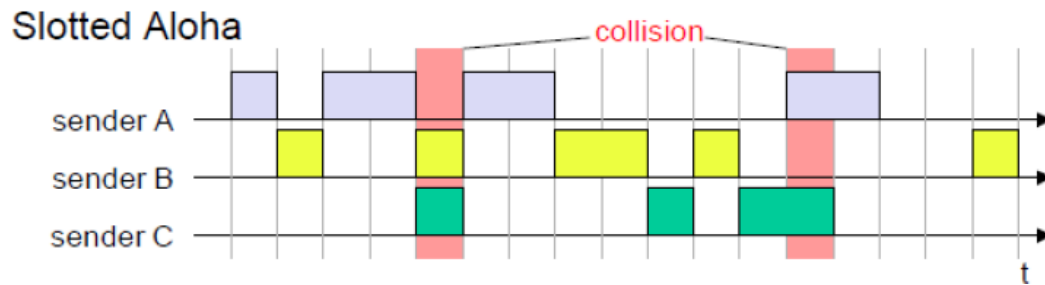

The introduction of slots raises the throughput from 18 per cent to 36 per cent, i.e., slotting doubles the throughput. Both basic Aloha principles occur in many systems that implement distributed access to a medium. Aloha systems work perfectly well under a light load, but they cannot give any hard transmission guarantees, such as maximum delay before accessing the medium or minimum throughput.

### Carrier sense multiple access[CSMA]

One improvement to the basic Aloha is sensing the carrier before accessing the medium. Sensing the carrier and accessing the medium only if the carrier is idle decreases the probability of a collision. But, as already mentioned in the introduction, hidden terminals cannot be detected, so, if a hidden terminal transmits at the same time as another sender, a collision might occur at the receiver. This basic scheme is still used in most wireless LANs. The different versions of CSMA are:

- 1-persistent CSMA:** Stations sense the channel and listen if it's busy and transmit immediately, when the channel becomes idle. It's called 1-persistent CSMA because the host transmits with a probability of 1 whenever it finds the channel idle.
- non-persistent CSMA:** stations sense the carrier and start sending immediately if the medium is idle. If the medium is busy, the station pauses a random amount of time before sensing the medium again and repeating this pattern.
- p-persistent CSMA:** systems nodes also sense the medium, but only transmit with a probability of  $p$ , with the station deferring to the next slot with the probability  $1-p$ , i.e., access is slotted in addition

CSMA with collision avoidance (**CSMA/CA**) is one of the access schemes used in wireless LANs following the standard IEEE 802.11. Here sensing the carrier is combined with a back-off scheme in case of a busy medium to achieve some fairness among competing stations.

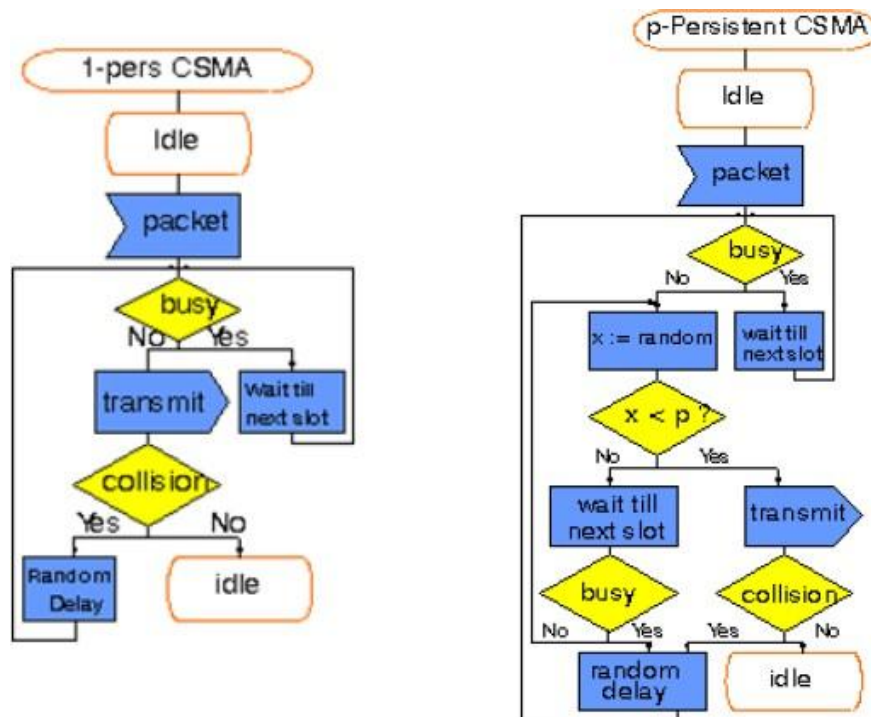

### DEMAND ASSIGNED MULTIPLE ACCESS[DAMA]

Channel efficiency for Aloha is 18% and for slotted Aloha is 36%. It can be increased to 80% by implementing reservation mechanisms and combinations with some (fixed) TDM patterns. These schemes typically have a reservation period followed by a transmission period. During the reservation period, stations can reserve future slots in the transmission period. While, depending on the scheme, collisions may occur during the reservation period, the transmission period can then be accessed without collision.

One basic scheme is **demand assigned multiple access (DAMA)** also called **reservation Aloha**, a scheme typical for satellite systems. It increases the amount of users in a pool of satellite channels that are available for use by any station in a network. It is assumed that not all users will need simultaneous access to the same communication channels. So that a call can be established, DAMA assigns a pair of available channels based on requests issued from a user. Once the call is completed, the channels are returned to the pool for an assignment to another call. Since the resources of the satellite are being used only in proportion to the occupied channels for the time in which they are being held, it is a perfect environment for voice traffic and data traffic in batch mode.

It has two modes as shown below.



During a contention phase following the slotted Aloha scheme; all stations can try to reserve future slots. Collisions during the reservation phase do not destroy data transmission, but only the short requests for data transmission. If successful, a time slot in the future is reserved, and no other station is allowed to transmit during this slot. Therefore, the satellite collects all successful requests (the others are destroyed) and sends back a reservation list indicating access rights for future slots. All ground stations have to obey this list. To maintain the fixed TDM pattern of reservation and transmission, the stations have to be synchronized from time to time. DAMA is an **explicit reservation** scheme. Each transmission slot has to be reserved explicitly.

### PRMA PACKET RESERVATION MULTIPLE ACCESS

It is a kind of implicit reservation scheme where, slots can be reserved implicitly. A certain number of slots form a frame. The frame is repeated in time i.e., a fixed TDM pattern is applied. A base station, which could be a satellite, now broadcasts the status of each slot to all mobile stations. All stations receiving this vector will then know which slot is occupied and which slot is currently free.

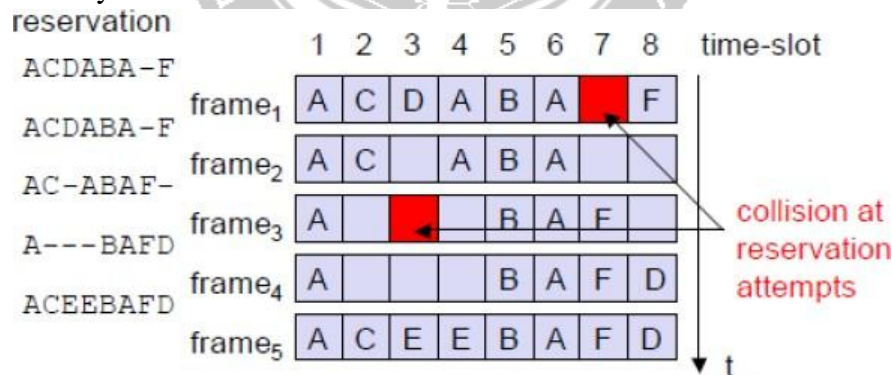

The base station broadcasts the reservation status 'ACDABA-F' to all stations, here A to F. This means that slots one to six and eight are occupied, but slot seven is free in the following transmission. All stations wishing to transmit can now compete for this free slot in Aloha fashion. The already occupied slots are not touched. In the example shown, more than one station wants to access this slot, so a collision occurs. The base station returns the reservation status 'ACDABA-F', indicating that the reservation of slot seven failed (still indicated as free) and that nothing has changed for the other slots. Again, stations can compete for this slot. Additionally, station D has stopped sending in slot three and station F in slot eight. This is noticed by the base station after the second frame. Before the third frame starts, the base station indicates

that slots three and eight are now idle. Station F has succeeded in reserving slot seven as also indicated by the base station.

As soon as a station has succeeded with a reservation, all future slots are implicitly reserved for this station. This ensures transmission with a guaranteed data rate. The slotted aloha scheme is used for idle slots only; data transmission is not destroyed by collision.

### RESERVATION TDMA

In a fixed TDM scheme  $N$  mini-slots followed by  $N \cdot k$  data-slots form a frame that is repeated. Each station is allotted its own mini-slot and can use it to reserve up to  $k$  data-slots.

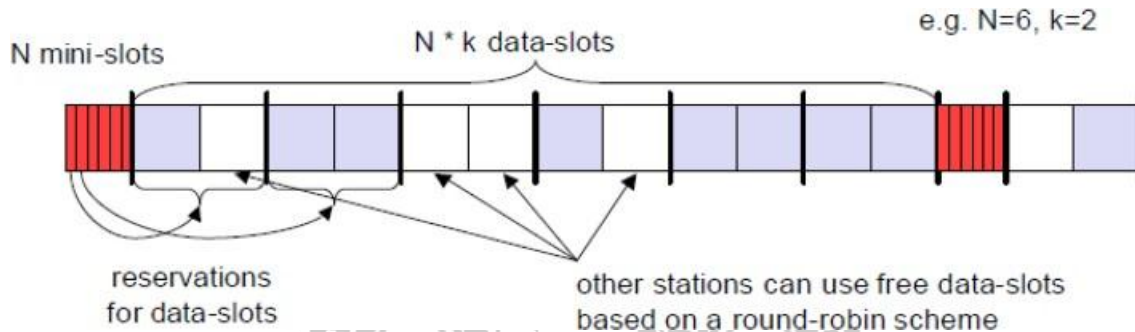

This guarantees each station a certain bandwidth and a fixed delay. Other stations can now send data in unused data-slots as shown. Using these free slots can be based on a simple round-robin scheme or can be uncoordinated using an Aloha scheme. This scheme allows for the combination of, e.g., isochronous traffic with fixed bitrates and best-effort traffic without any guarantees.

### Multiple access with collision avoidance [MACA]

Multiple access with collision avoidance (MACA) presents a simple scheme that solves the hidden terminal problem, does not need a base station, and is still a random access Aloha scheme – but with dynamic reservation. Consider the hidden terminal problem scenario.

A starts sending to B, C does not receive this transmission. C also wants to send something to B and senses the medium. The medium appears to be free, the carrier sense fails. C also starts sending causing a collision at B. But A cannot detect this collision at B and continues with its transmission. A is **hidden** for C and vice versa.

With MACA, A does not start its transmission at once, but sends a **request to send (RTS)** first. B receives the RTS that contains the name of sender and receiver, as well as the length of the future transmission. This RTS is not heard by C, but triggers an acknowledgement from B, called **clear to send (CTS)**. The CTS again contains the names of sender (A) and receiver (B) of the user data, and the length of the future transmission.

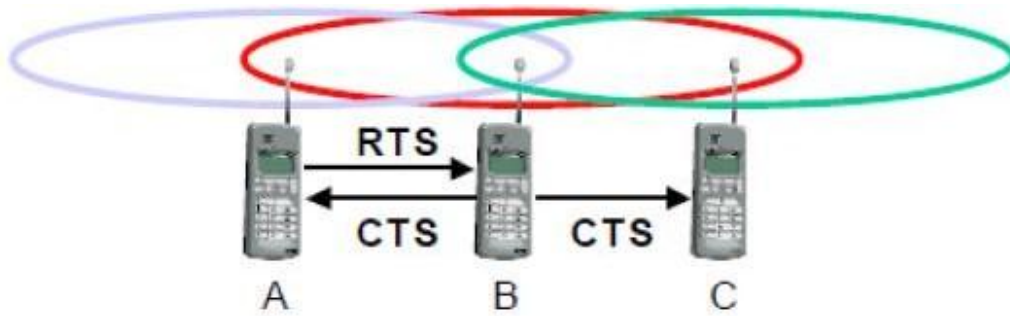

This CTS is now heard by C and the medium for future use by A is now reserved for the duration of the transmission. After receiving a CTS, C is not allowed to send anything for the duration indicated in the CTS toward B. A collision cannot occur at B during data transmission, and the hidden terminal problem is solved. Still collisions might occur when A and C transmits a RTS at the same time. B resolves this contention and acknowledges only one station in the CTS. No transmission is allowed without an appropriate CTS.

Now MACA tries to avoid the **exposed terminals** in the following way:

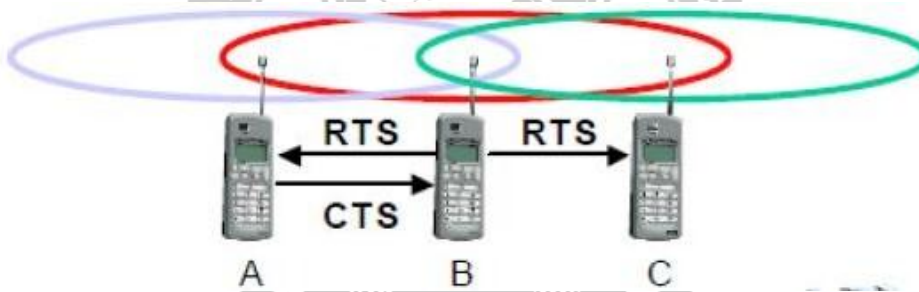

With MACA, B has to transmit an RTS first containing the name of the receiver (A) and the sender (B). C does not react to this message as it is not the receiver, but A acknowledges using a CTS which identifies B as the sender and A as the receiver of the following data transmission. C does not receive this CTS and concludes that A is outside the detection range. C can start its transmission assuming it will not cause a collision at A. The problem with exposed terminals is solved without fixed access patterns or a base station.

## POLLING

Polling schemes are used when one station wants to be heard by others. Polling is a strictly centralized scheme with one master station and several slave stations. The master can poll the slaves according to many schemes: round robin (only efficient if traffic patterns are similar over all stations), randomly, according to reservations (the classroom example with polite students) etc. The master could also establish a list of stations wishing to transmit during a contention phase. After this phase, the station polls each station on the list.

Example: Randomly Addressed Polling

- base station signals readiness to all mobile terminals
- terminals ready to send transmit random number without collision using CDMA or FDMA
- the base station chooses one address for polling from list of all random numbers (collision if two terminals choose the same address)
- the base station acknowledges correct packets and continues polling the next terminal
- this cycle starts again after polling all terminals of the list

**INHIBIT SENSE MULTIPLE ACCESS**

This scheme, which is used for the packet data transmission service Cellular Digital PacketData (CDPD) in the AMPS mobile phone system, is also known as **digital sense multiple access(DSMA)**. Here, the base station only signals a busy medium via a busy tone (called BUSY/IDLE indicator) on the downlink.

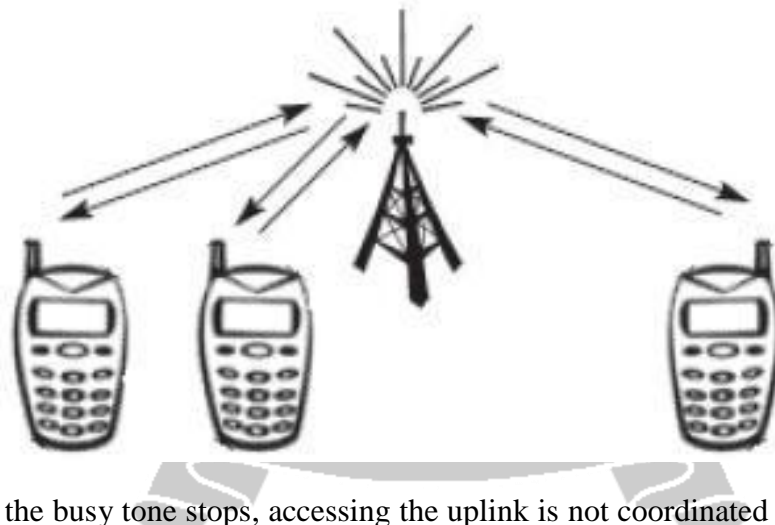

After the busy tone stops, accessing the uplink is not coordinated any further. The base station acknowledges successful transmissions; a mobile station detects a collision only via the missing positive acknowledgement. In case of collisions, additional back-off and retransmission mechanisms are implemented.



## CODE DIVISION MULTIPLE ACCESS [CDMA]

Code division multiple access systems apply codes with certain characteristics to the transmission to separate different users in code space and to enable access to a shared medium without interference.

All terminals send on the same frequency probably at the same time and can use the whole bandwidth of the transmission channel. Each sender has a unique random number, the sender XORs the signal with this random number. The receiver can “tune” into this signal if it knows the pseudo random number, tuning is done via a correlation function

### Disadvantages:

1. higher complexity of a receiver (receiver cannot just listen into the medium and start receiving if there is a signal)
2. all signals should have the same strength at a receiver

### Advantages:

1. all terminals can use the same frequency, no planning needed
2. huge code space (e.g. 232) compared to frequency space
3. interferences (e.g. white noise) is not coded
4. forward error correction and encryption can be easily integrated

- Sender A
  - sends  $A_d = 1$ , key  $A_k = 010011$  (assign: “0” = -1, “1” = +1)
  - sending signal  $A_s = A_d * A_k = (-1, +1, -1, -1, +1, +1)$
- Sender B
  - sends  $B_d = 0$ , key  $B_k = 110101$  (assign: “0” = -1, “1” = +1)
  - sending signal  $B_s = B_d * B_k = (-1, -1, +1, -1, +1, -1)$
- Both signals superimpose in space
  - interference neglected (noise etc.)
  - $A_s + B_s = (-2, 0, 0, -2, +2, 0)$
- Receiver wants to receive signal from sender A
  - apply key  $A_k$  bitwise (inner product)
    - $A_e = (-2, 0, 0, -2, +2, 0) \bullet A_k = 2 + 0 + 0 + 2 + 2 + 0 = 6$
    - result greater than 0, therefore, original bit was “1”
  - receiving B
    - $B_e = (-2, 0, 0, -2, +2, 0) \bullet B_k = -2 + 0 + 0 - 2 - 2 + 0 = -6$ , i.e. “0”

The following figure shows a sender A that wants to transmit the bits 101. The key of A is shown as signal and binary sequence  $A_k$ . The binary “0” is assigned a positive signal value, the binary “1” a negative signal value. After spreading, i.e., XORing  $A_d$  and  $A_k$ , the resulting signal is  $A_s$ .

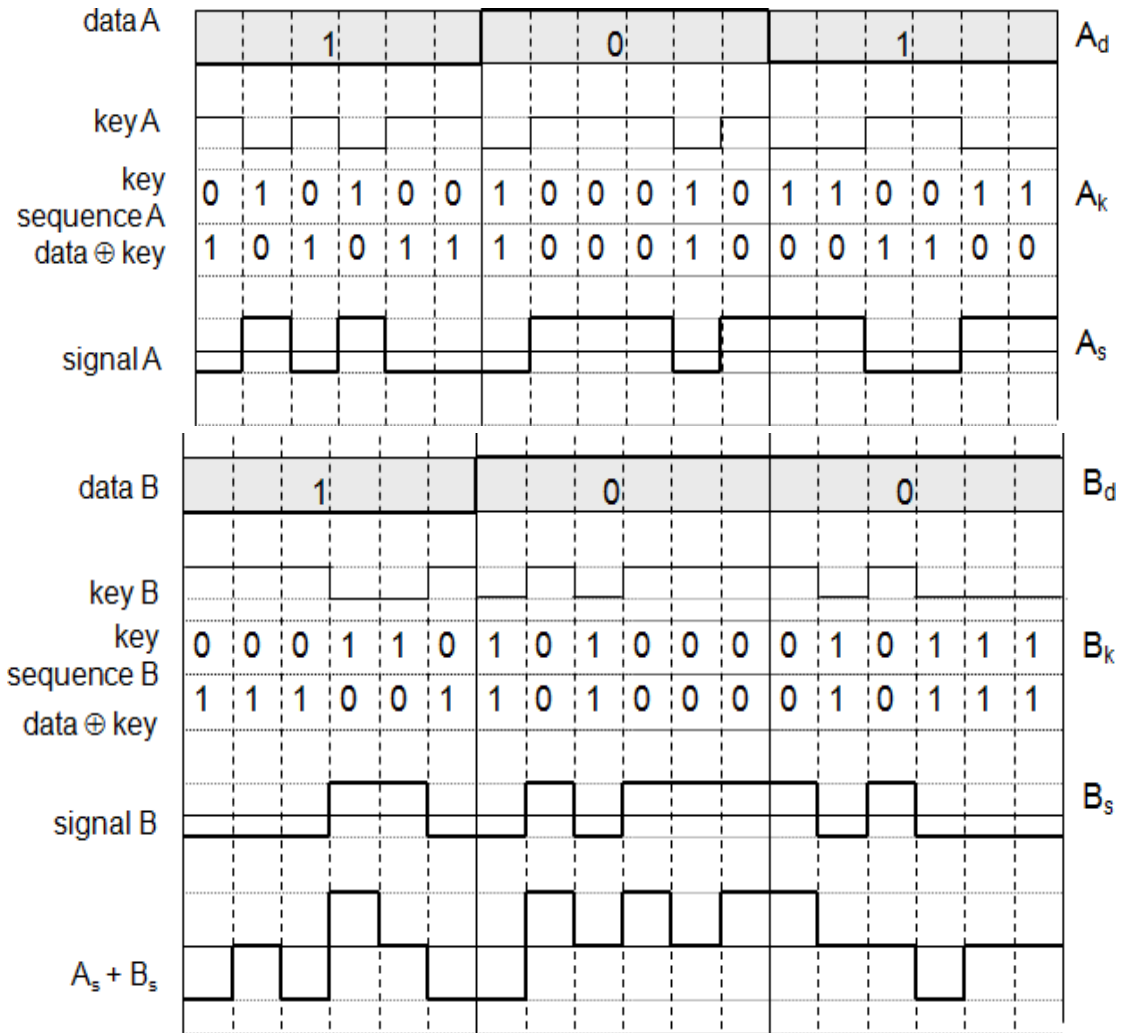

**Coding and spreading of data from sender A and sender B**

The same happens with data from sender B with bits 100. The result is  $B_s$ .  $A_s$  and  $B_s$  now superimpose during transmission. The resulting signal is simply the sum  $A_s + B_s$  as shown above. A now tries to reconstruct the original data from  $A_d$ . The receiver applies A's key,  $A_k$ , to the received signal and feeds the result into an integrator. The integrator adds the products, a comparator then has to decide if the result is a 0 or a 1 as shown below. As clearly seen, although the original signal form is distorted by B's signal, the result is quite clear. The same happens if a receiver wants to receive B's data.

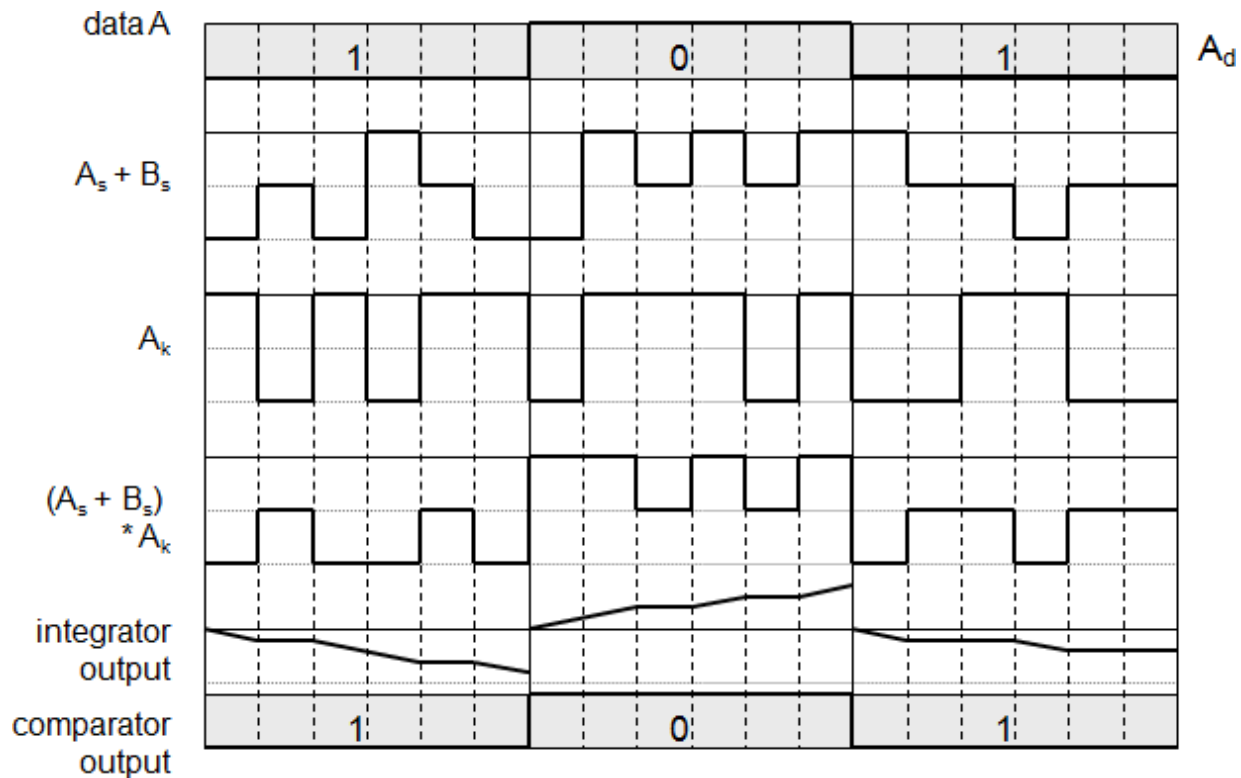

**Reconstruction of A's data**

**Soft handover** or **soft handoff** refers to a feature used by the CDMA and WCDMA standards, where a cell phone is simultaneously connected to two or more cells (or cell sectors) during a call. If the sectors are from the same physical cell site (a sectorised site), it is referred to as **softer handoff**. This technique is a form of mobile-assisted handover, for IS-95/CDMA2000 CDMA cell phones continuously make power measurements of a list of neighboring cell sites, and determine whether or not to request or end soft handover with the cell sectors on the list.

Soft handoff is different from the traditional hard-handoff process. With hard handoff, a definite decision is made on whether to hand off or not. The handoff is initiated and executed without the user attempting to have simultaneous traffic channel communications with the two base stations. With soft handoff, a *conditional* decision is made on whether to hand off. Depending on the changes in pilot signal strength from the two or more base stations involved, a hard decision will eventually be made to communicate with only one. This normally happens after it is evident that the signal from one base station is considerably stronger than those from the others. In the interim period, the user has simultaneous traffic channel communication with all candidate base stations. It is desirable to implement soft handoff in power-controlled CDMA systems because implementing hard handoff is potentially difficult in such systems.

## Spread Aloha multiple access (SAMA)

CDMA senders and receivers are not really simple devices. Communicating with  $n$  devices requires programming of the receiver to be able to decode  $n$  different codes. Aloha was a very simple scheme, but could only provide a relatively low bandwidth due to collisions. SAMA uses spread spectrum with only one single code (chipping sequence) for spreading for all senders accessing according to aloha.

In SAMA, each sender uses the same spreading code, for ex 110101 as shown below. Sender A and B access the medium at the same time in their narrowband spectrum, so that the three bits shown causes collisions. The same data could also be sent with higher power for shorter periods as show.

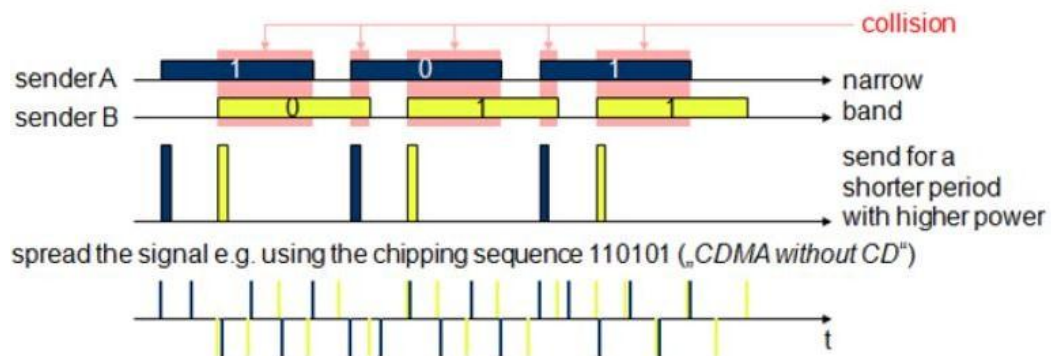

The main problem in using this approach is finding good chipping sequences. The maximum throughput is about 18 per cent, which is very similar to Aloha, but the approach benefits from the advantages of spread spectrum techniques: robustness against narrowband interference and simple coexistence with other systems in the same frequency bands.

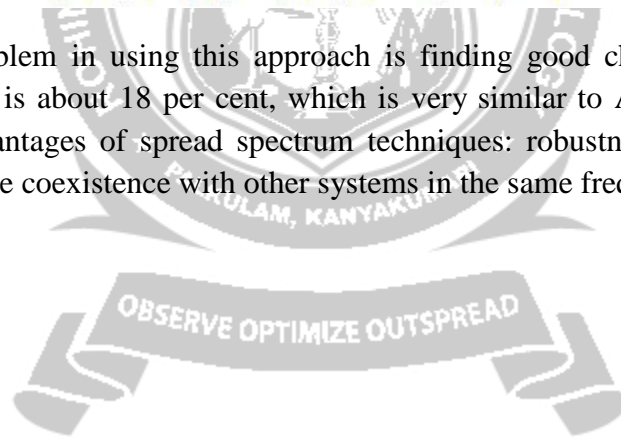

## Comparison SDMA/TDMA/FDMA/CDMA

Approach	SDMA	TDMA	FDMA	CDMA
Idea	segment space into cells/sectors	segment sending time into disjoint time-slots, demand driven or fixed patterns	segment the frequency band into disjoint sub-bands	spread the spectrum using orthogonal codes
Terminals	only one terminal can be active in one cell/one sector	all terminals are active for short periods of time on the same frequency	every terminal has its own frequency, uninterrupted	all terminals can be active at the same place at the same moment, uninterrupted
Signal separation	cell structure, directed antennas	synchronization in the time domain	filtering in the frequency domain	code plus special receivers
Advantages	very simple, increases capacity per km <sup>2</sup>	established, fully digital, flexible	simple, established, robust	flexible, less frequency planning needed, soft handover
Dis-advantages	inflexible, antennas typically fixed	guard space needed (multipath propagation), synchronization difficult	inflexible, frequencies are a scarce resource	complex receivers, needs more complicated power control for senders
Comment	only in combination with TDMA, FDMA or CDMA useful	standard in fixed networks, together with FDMA/SDMA used in many mobile networks	typically combined with TDMA (frequency hopping patterns) and SDMA (frequency reuse)	still faces some problems, higher complexity, lowered expectations; will be integrated with TDMA/FDMA

