

UNIT III TUNED AMPLIFIERS

Coil losses, unloaded and loaded Q of tank circuits, small signal tuned amplifiers - Analysis of capacitor coupled single tuned amplifier - Double tuned amplifier - Effect of cascading single tuned and double tuned amplifiers on bandwidth - Stagger tuned amplifiers - Stability of tuned amplifiers - Neutralization - Hazeltine neutralization method.

3.5.Neutralization**3.5.1.Neutralization Method:**

Fig 3.5.1 . Neutralization Method

- The tuned RF amplifiers, transistor are used at the frequencies nearer to their unity gain bandwidths (i.e. f_T), to amplify a narrow band of high frequencies centred around a radio frequency.
- At this frequency, the inter junction capacitance between base and collector, C_{bc} of the transistor becomes dominant, i.e., its reactance becomes low enough to be considered, which is otherwise infinite to be neglected as open circuit.
- Being CE configuration capacitance C_{bc} , shown in the fig. 3.35 come across input and output circuits of an amplifier.
- As reactance of C_{bc} at RF is low enough it provides the feedback path from collector

to base.

- With this circuit condition, if some feedback signal manages to reach the input from output in a positive manner with proper phase shift, then there is possibility of circuit converted to a positive manner with proper phase shift, then there is possibility of circuit converted to an unstable one, generating its own oscillations and can stop working as an amplifier.
- This circuit will always oscillate if enough energy is fed back from the collector to the base in the correct phase to overcome circuit losses. Unfortunately, the conditions for best gain and selectivity are also those which promote oscillation. In order to prevent oscillations in tuned RF amplifiers it was necessary to reduce the stage gain to a level that ensured circuit stability.
- This could be accomplished in several ways such as lowering the Q of tune circuits; stager tuning, losse coupling. between the stages or inserting a 'loser' element into the circuit.
- While all these methods reduced gain, detuning and Q reduction had detrimental effects on selectivity.
- Instead of losing the circuit performance to achieve stability, the professor L.A. Hazeltine introduced a circuit in which the troublesome effect o the collector to base capacitance of the transistor was neutralized by introducing a signal which cancels the signal coupled through the collector to base capacitance.
- He proved that the neutralization can be achieved by deliberately feeding back a portion of the output signal to the input in such a way that it has the same amplitude as the unwanted feedback but the opposite phase.
- Later on many neutralizing circuits were introduced. Let us study some of these circuits.

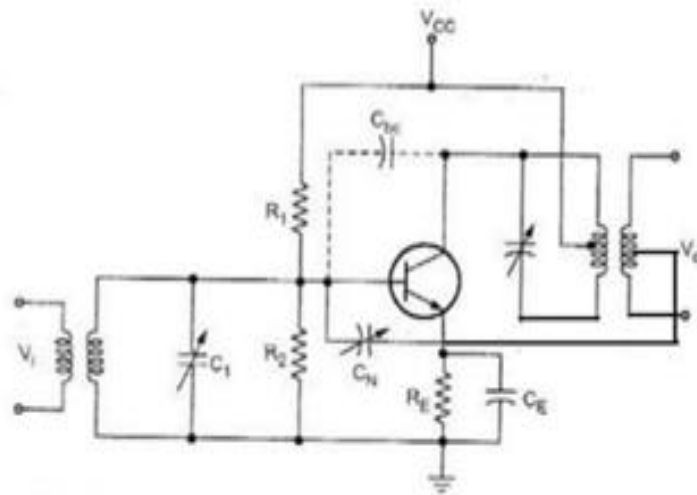
3.5.2. Hazeltine Neutralization:

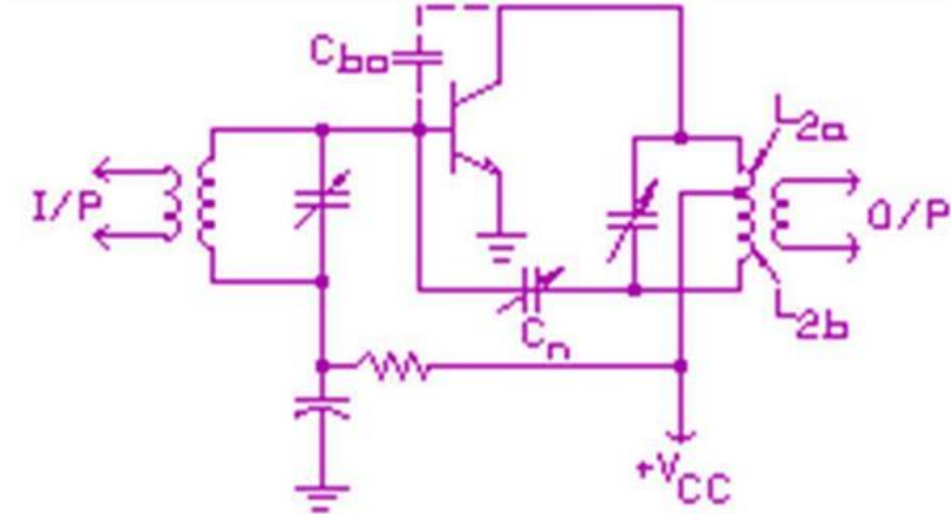

Fig 3.5.2 . Hazeltine Neutralization

- Fig shows one variation of the Hazeltine circuit. In this circuit a small value of variable capacitance C_N is connected from the bottom of coil, point B, to the base.
- Therefore, the internal capacitance C_{bc} , shown dotted, feeds a signal from the top end of the coil, point A, to the transistor base and the C_N feeds a signal of equal magnitude but opposite polarity from the bottom of coil, point B, to the base.
- The neutralizing capacitor, C_N can be adjusted correctly to completely nullify the signal fed through the C_{bc} .

3.5.3. Neutralization using coil:

- Fig. shows the neutralization of RF amplifier using coil. In this circuit, L part of the tuned circuit at the base of next stage is oriented for minimum coupling to the other winding.
- It is wound on a separate form and is mounted at right angle to the coupled windings.

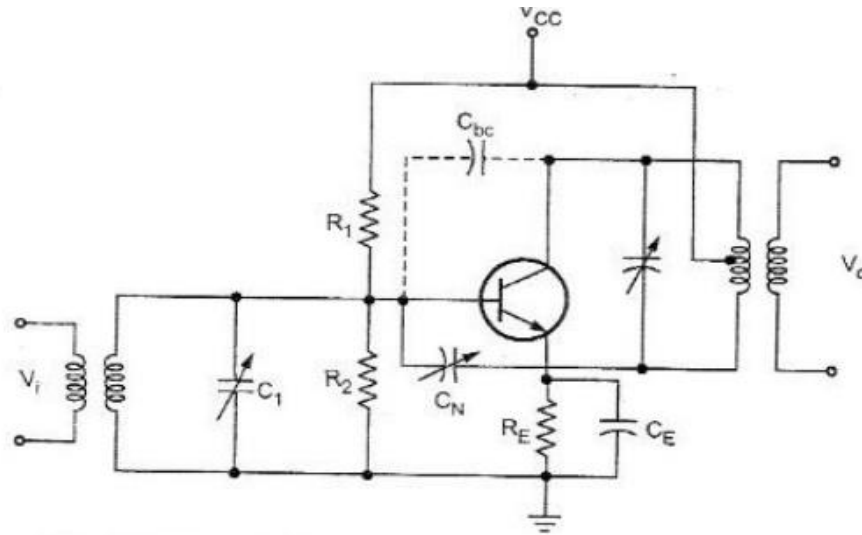

Fig. 3.5.3. Neutralization using coil

- If the windings are properly polarized, the voltage across L due to the circulating current in the base circuit will have the proper phase to cancel the signal coupled through the base to collector, C_{bc} capacitance.

