

UNIT-III
TRANSMISSION SYSTEMS

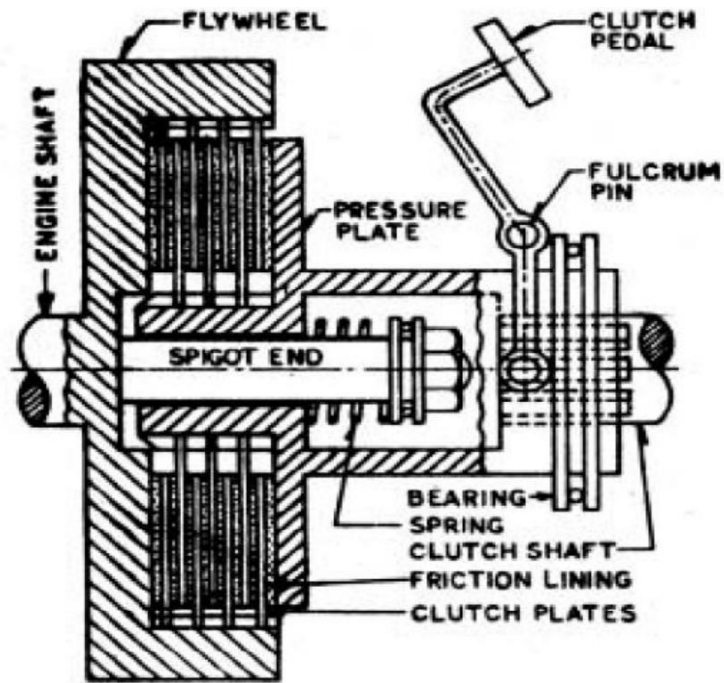
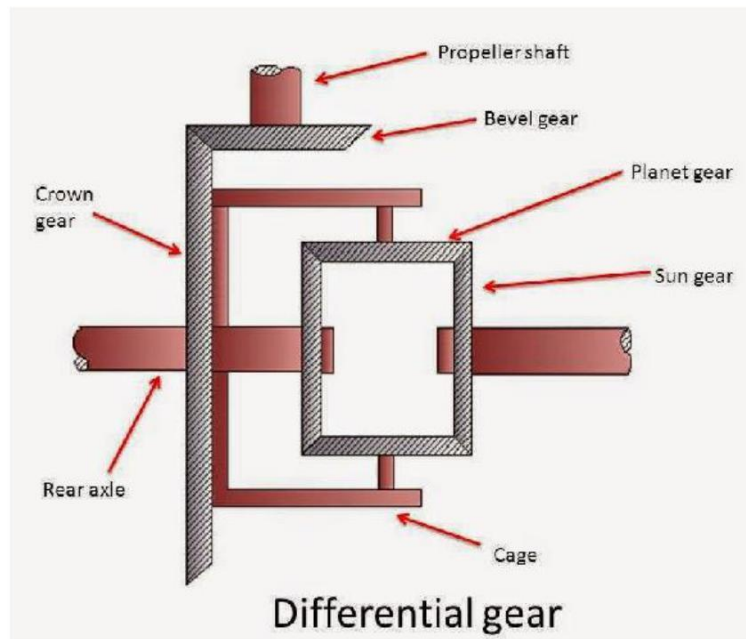
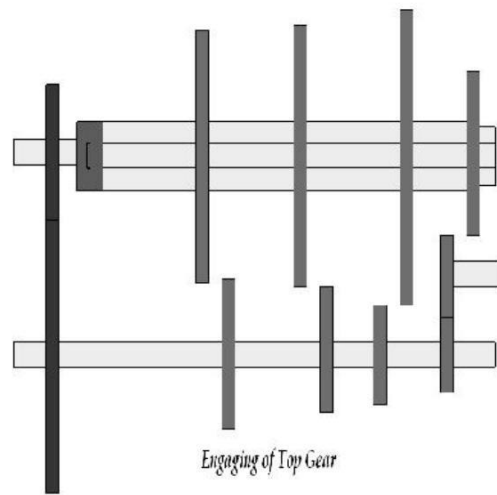
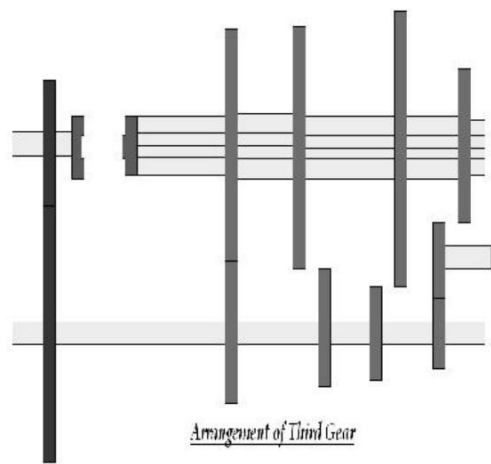
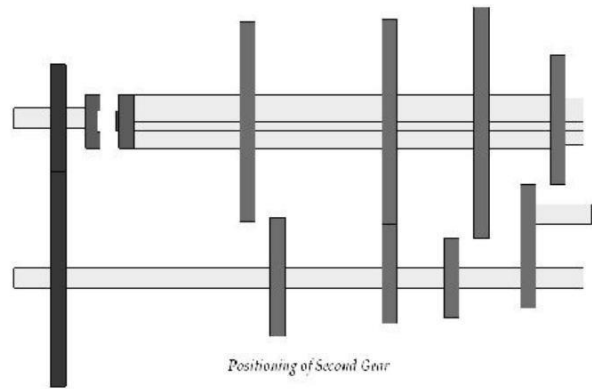
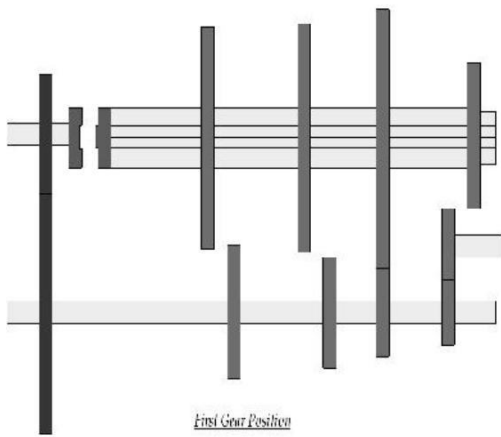
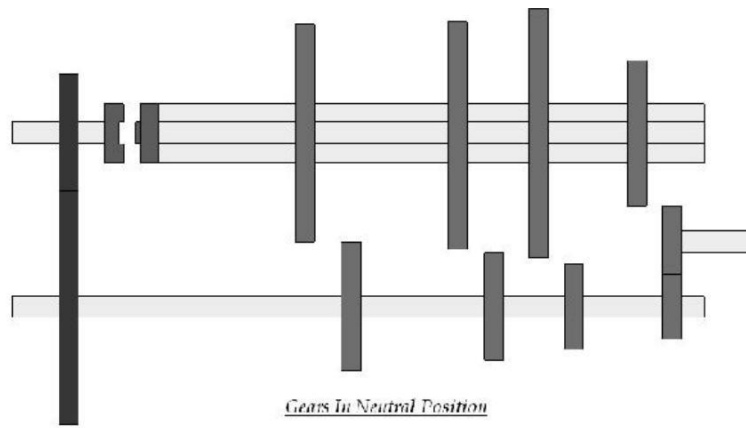

Fig : Multi-Plate Clutch





3.1. Introduction to the Transmission Systems in Automobile:

The most common transmission systems that have been used for the automotive industry are:

- Manual transmission,
- Automatic transmission,
- Semi-automatic transmission,
- Continuously-variable transmission (C.V.T.).

3.1.1. Manual Transmission:

The first transmission invented was the manual transmission system. The driver needs to disengage the clutch to disconnect the power from the engine first, select the target gear, and engage the clutch again to perform the gear change. This will challenge a new driver. It always takes time for a new driver to get used to this skill.

3.1.2. Automatic Transmission:

An automatic transmission uses a fluid-coupling torque converter to replace the clutch to avoid engaging/disengaging clutch during gear change. A completed gear set, called planetary gears, is used to perform gear ratio change instead of selecting gear manually. A driver no longer needs to worry about gear selection during driving. It makes driving a car much easier, especially for a disabled or new driver. However, the indirect gear contact of the torque converter causes power loss during power transmission, and the complicated planetary gear structure makes the transmission heavy and easily broken.

3.1.3. Semi-Automatic Transmission:

A semi-automatic transmission tries to combine the advantages of the manual and automatic transmission systems, but avoid their disadvantages. However, the complicated design of the semi-automatic transmission is still under development, and the price is not cheap. It is only used for some luxury or sports cars currently.

Continuously Variable Transmission (C.V.T.):-

The Continuously Variable Transmission (C.V.T.) is a transmission in which the ratio of the rotational speeds of two shafts, as the input shaft and output shaft of a vehicle or other machine, can be varied continuously within a given range, providing an infinite number of possible ratios. The other mechanical transmissions described above only allow a few different gear ratios to be selected, but this type of transmission essentially has an infinite number of ratios available within a finite range.

It provides even better fuel economy if the engine is constantly made run at a single speed. This transmission is capable of a better user experience, without the rise and fall in speed of an engine, and the jerk felt when changing gears.

MANUAL TRANSMISSION SYSTEM

Manual transmissions also referred as stick shift transmission or just 'stick', 'straight drive', or standard transmission because you need to use the transmission stick every time you change the gears. To perform the gear shift, the transmission system must first be disengaged from the engine. After the target gear is selected, the transmission and engine are engaged with each other again to perform the power transmission. Manual transmissions are characterized by gear ratios that are selectable by locking selected gear pairs to the output shaft inside the transmission.

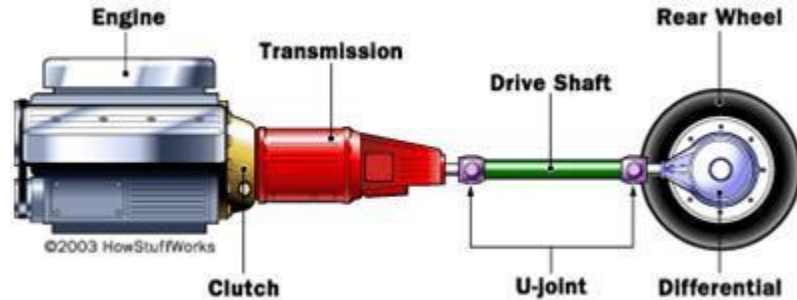

The transmission system delivers the engine power to wheels.

Components of manual transmission

The main components of manual transmission are:

- Clutch
- Gear box
- U- joint
- Shafts
- Differential gear box

3.2. Clutch:

Clutch is a device which is used in the transmission system of automobile to engage and disengage the engine to the transmission or gear box. It is located between the transmission and the engine. When the clutch is engaged, the power flows from the engine to the rear wheels in a rear-wheel-drive transmission and the vehicle moves. When the clutch is disengaged, the power is not transmitted from the engine to the rear wheels and vehicle stops even if engine is running.

It works on the principle of friction. When two friction surfaces are brought in contact with each other and they are united due to the friction between them. If one is revolved the other will also revolve.

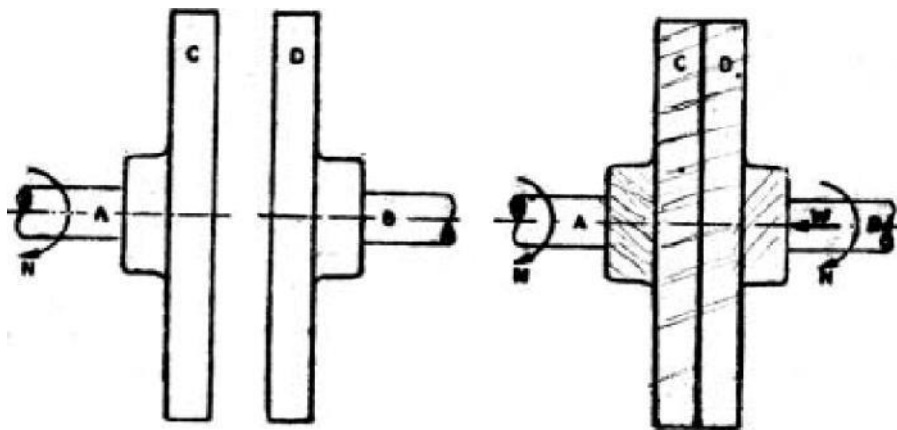

Fig: Principle of Clutch

The friction depends upon the surface area contact. The friction surfaces are so designed that the driven member initially slips on driving member when initially pressure is applied. As pressure increases the driven member is brought gradually to speed the driving member.

The three main parts of clutch are:

- Driving member
- Driven member
- Operating member

The driving member consists of a flywheel mounted on the engine crank shaft. The flywheel is bolted to cover which carries a pressure plate or driving disc, pressure springs and releasing levers. Thus the entire assembly of flywheel and cover rotates all the times. The clutch housing and the cover provided with openings dissipate the heat generated by friction during the clutch operation.

The driving member consists of a disc or plate called clutch plate. It is free to slide length wise on the splines of the clutch shaft. It carries friction materials on both of its surfaces when it is gripped between the flywheel and the pressure plate; it rotates the clutch shaft through splines.

The operating members consists of a foot pedal, linkage, release or throw-out bearing, release levers and springs necessary to ensure the proper operation of the clutch.

Now the driving member in an automobile is flywheel mounted on crank shaft, the driven member is the pressure plate mounted on transmission or gear box input shaft. Friction surfaces or clutch plates is placed between two members.

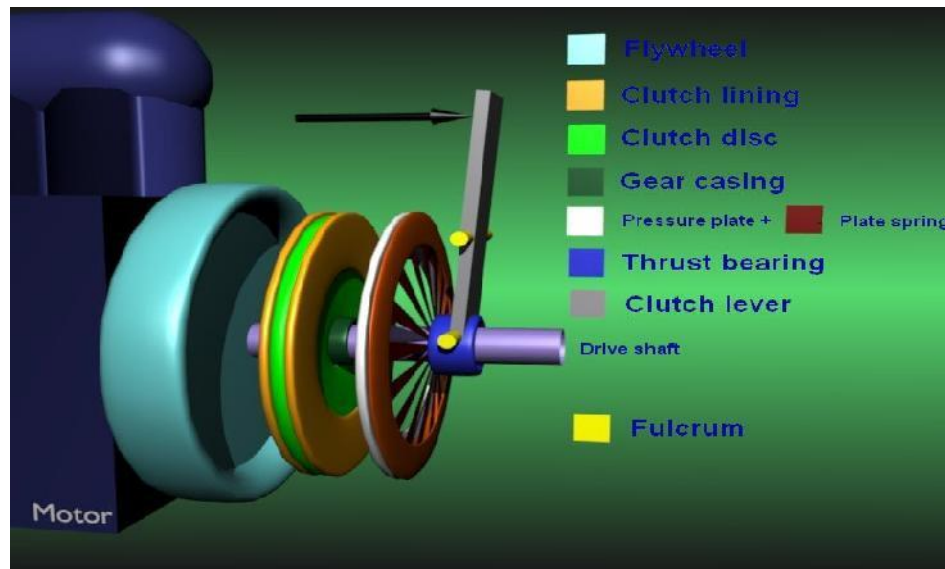

Fig: Exploded view of clutch

Types of Friction Materials:

The friction materials of the clutch plate are generally of 3 types:

- Mill Board Type
- Molded type
- Woven type

Mill Board type friction materials mainly include asbestos material with different types of impregnates.

Molded type friction materials are made from a matrix of asbestos fiber and starch or any other suitable binding materials. They are then heated to a certain temperature for moulding in dies under pressure. They are also made into sheets by rolling, pressing and backs till they are extremely hard and dense. Metallic wires are used sometimes to increase wear properties.

Woven types facing materials are made by impregnating a cloth with certain binders or by weaving threads of copper or brass wires covered with long fiber asbestos and cotton. The woven sheets treated with binding solution are baked and rolled.

Properties Of Good Clutching:

- Good Wearing Properties
- High Resistance to heat
- High coefficient of friction
- Good Binders in it

Operation of Clutch:

When the clutch pedal is pressed through pedal movement, the clutch release bearing presses on the clutch release lever plate which being connected to clutch release levers, forces these levers forward. This causes the pressure plate to compress pressure springs, thus allowing it to move away from the clutch driven plate. This action releases the pressure on the driven plate and flywheel, the flywheel is now free to turn independently, without turning the transmission.

When the clutch pedal is released, reverse action takes place i.e. the driven plate is again forced against the flywheel by the pressure plate- because of the force exerted by pressure springs. The pressure plate will keep on pressing the facings of driven plate until friction created becomes equal to the resistance of the vehicle. Any further increase in pressure will cause the clutch plate and the transmission shaft to turn along with flywheel, thus achieving vehicle movement.

3.2.1 Single Clutch Plate:

It is the most common type of clutch plate used in motor vehicles. Basically it consists of only one clutch plate, mounted on the splines of the clutch plate. The flywheel is mounted on engine crankshaft and rotates with it. The pressure plate is bolted to the flywheel through clutch springs, and is free to slide on the clutch shaft when the clutch pedal is operated. When the clutch is engaged the clutch plate is gripped between the flywheel and pressure plate. The friction linings are on both the sides of the clutch plate. Due to the friction between the flywheel, clutch plate and the pressure plate the clutch plate revolves the flywheel. As the clutch plate revolves the clutch shaft also revolves. Clutch shaft is connected to the transmission gear box. Thus the engine power is transmitted to the crankshaft and then to the clutch shaft.

When the clutch pedal is pressed, the pressure plate moves back against the force of the springs, and the clutch plate becomes free between the flywheel and the pressure plate. Thus the flywheel remains rotating as long as the engine is running and the clutch shaft speed reduces slowly and finally it stops rotating. As soon as the clutch pedal is pressed, the clutch is said to be engaged, otherwise it remains engaged due to the spring forces.

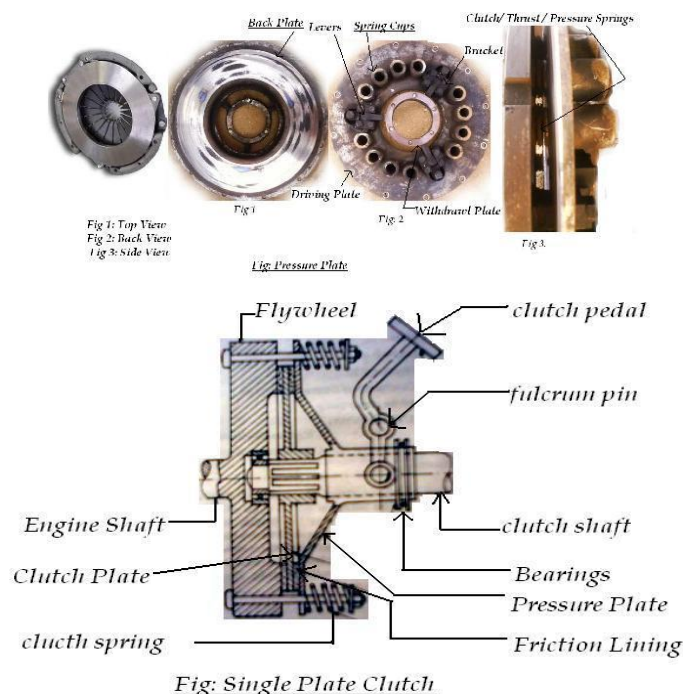

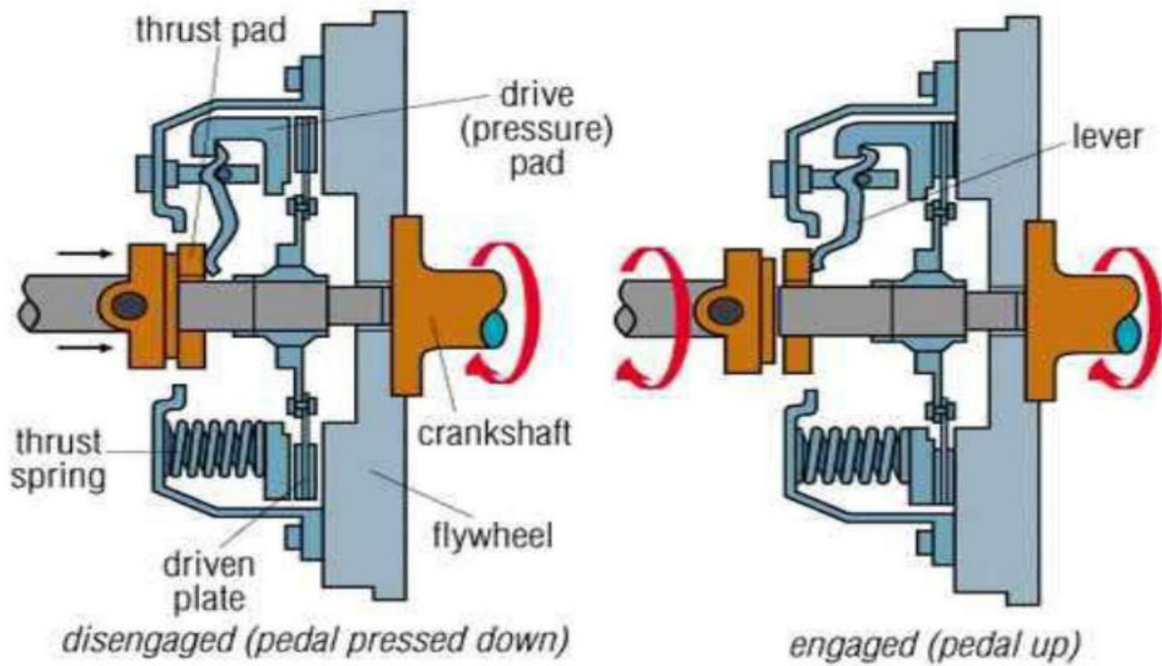
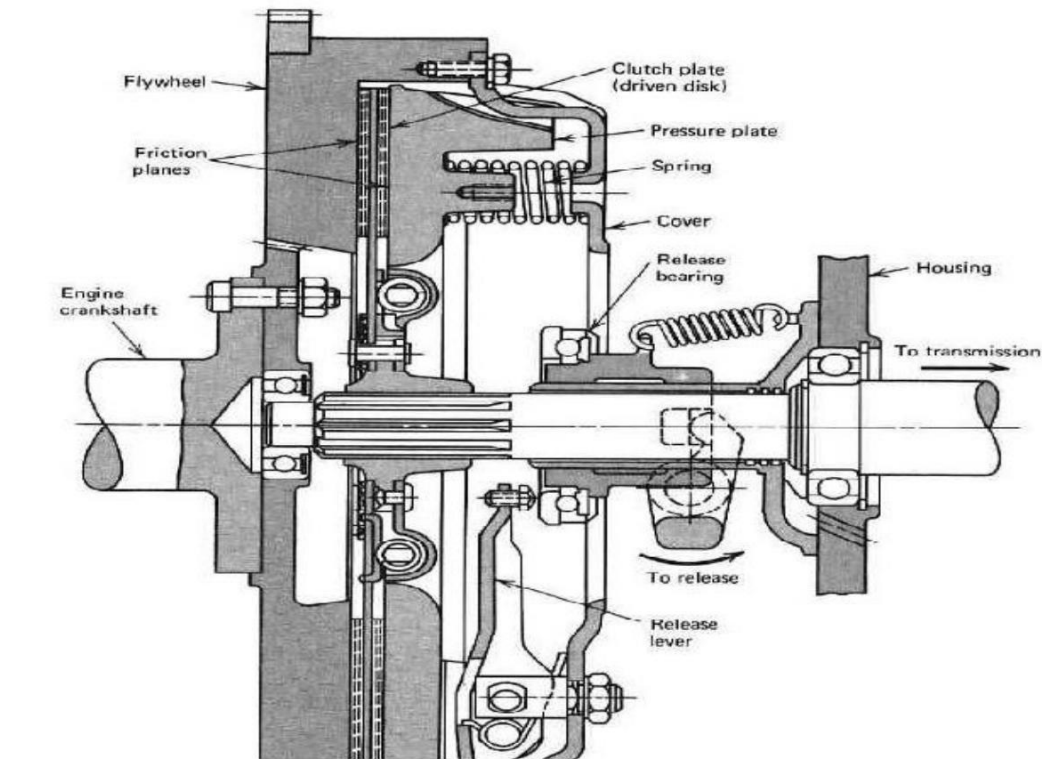

Fig: Clutch in Engaged & Disengaged Position



3.2.2. Multi-plate Clutch:

Multi-plate clutch consists of a number of clutch plates instead of only one clutch plate as in case of single plate clutch. As The number of clutch plates are increased, the friction surfaces also increases. The increased number of friction surfaces obviously increases the capacity of the clutch to transmit torque.

The plates are alternately fitted to engine and gear box shaft. They are firmly pressed by strong coil springs and assembled in a drum. Each of the alternate plate slides on the grooves on the flywheel and the other slides on splines on the pressure plate. Thus, each alternate plate has inner and outer splines.

The multi-plate clutch works in the same way as a single plate clutch by operating the clutch pedal. The multi-plate clutches are used in heavy commercial vehicles, racing cars and motor cycles for transmitting high torque. The multi-plate clutch may be dry or wet. When the clutch is operated in an oil bath, it is called a wet clutch. When the clutch is operated dry it is called dry clutch. The wet clutch is used in conjunction with or part of the automatic transmission.

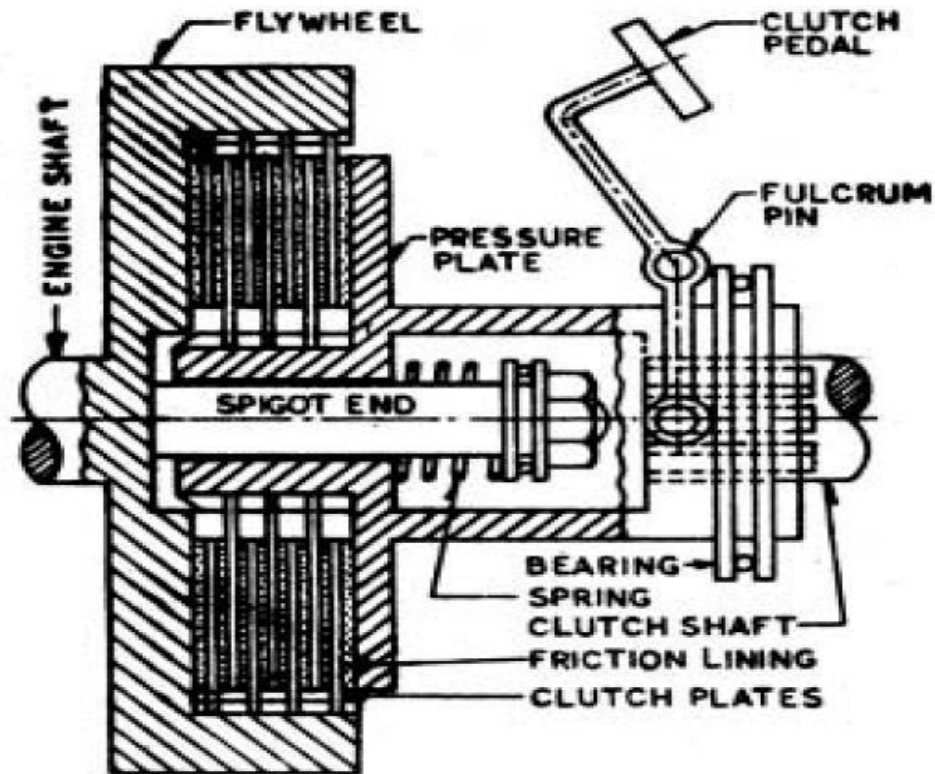

Fig : Multi-Plate Clutch



Fig: Cutaway Model Of Multi-Plate Clutch



Fig: Exploded View Of Multi-Plate Clutch

Fig: Multi-Plate Clutch

3.2.3. Cone Clutch:

Cone clutch consists of friction surfaces in the form of cone. The engine shaft consists of female cone. The male cone is mounted on the splined clutch shaft. It has friction surfaces on the conical portion. The male cone can slide on the clutch shaft. When the clutch is engaged the friction surfaces of the male cone are in contact with that of the female cone due to force of the spring. When the clutch pedal is pressed, the male cone slides against the spring force and the clutch is disengaged.

The only advantage of the cone clutch is that the normal force acting on the friction surfaces is greater than the axial force, as compare to the single plate clutch in which the normal force acting on the friction surfaces is equal to the axial force. The disadvantage in cone clutch is that if the angle of the cone is made smaller than 200 the male cone tends to bind in the female cone and it becomes difficult to disengage the clutch. Cone clutches are generally now only used in low peripheral speed applications although they were once common in automobiles and other combustion engine transmissions. They are usually now confined to very specialist transmissions in racing, rallying, or in extreme off-road vehicles, although they are common in power boats. Small cone clutches are used in synchronizer mechanisms in manual transmissions.

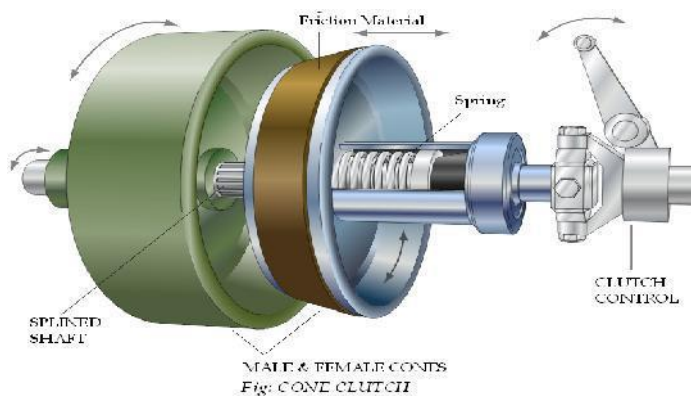

Fig: CONE CLUTCH

3.2.4. Dog & Spline Clutch:

This type of clutch is used to lock two shafts together or to lock a gear to shaft. It consists of a sleeve having two sets of internal splines. It slides on a splined shaft with smallest diameter splines. The bigger diameter splines match with the external dog clutch teeth on driving shaft. When the sleeve is made to slide on the splined shaft, its teeth match with the dog clutch teeth of the driving shaft. Thus the sleeve turns the splined shaft with the driving shaft.

The clutch is said to be engaged. To disengage the clutch, the sleeve is moved back on the splined shaft to have no contact with the driving shaft. This type of clutch has no tendency to slip. The driven shaft revolves exactly at the same speed of the driving shaft, as soon as the clutch is engaged. This is also known as positive clutch.

3.2.5. Centrifugal Clutch:

The centrifugal clutch uses centrifugal forces, instead of spring force for keeping it in engaged position. Also, it does not require clutch pedal for operating the clutch. The clutch is operated automatically depending on engine speed. The vehicle can be stopped in gear without stalling the engine. Similarly the gear can be started in any gear by pressing the accelerator pedal.

A centrifugal clutch works through centrifugal force. The input of the clutch is connected to the engine crankshaft while the output drives gear box shaft, chain, or belt. As engine R.P.M. increases, weighted arms in the clutch swing outward and force the clutch to engage. The most common types have friction pads or shoes radially mounted that engage the inside of the rim of housing.

On the center shaft there are an assorted amount of extension springs, which connect to a clutch shoe. When the center shaft spins fast enough, the springs extend causing the clutch shoes to engage the friction face. It can be compared to a drum brake in reverse. The weighted arms force these disks together and engage the clutch.

When the engine reaches a certain RPM, the clutch activates, working almost like a continuously variable transmission. As the load increases the R.P.M. drops thereby disengaging the clutch and letting the rpm rise again and reengaging the clutch. If tuned properly, the clutch will tend to keep the engine at or near the torque peak of the engine.

These results in a fair bit of waste heat, but over a broad range of speeds it is much more useful than a direct drive in many applications. Weaker spring/heavier shoes will cause the clutch to engage at a lower R.P.M. while a stronger spring/lighter shoes will cause the clutch to engage at a higher R.P.M.

Semi-centrifugal Clutch:-

A semi centrifugal clutch is used to transmit power from high powered engines and racing car engines where clutch disengagements requires appreciable and tiresome drivers effort. The transmission of power in such clutches is partly by clutch springs and rest by centrifugal action of an extra weight provided in system. The clutch springs serve to transmit the torque up to normal speeds, while the centrifugal force assists at speeds higher than normal.

Besides clutch, pressure plate and splines shaft it mainly consists of:

Compression spring (3 numbers)

Weighted levers (3 numbers)

At normal speeds when the power transmission is low the spring keeps the clutch engaged, the weighted levers do not have any pressure on the pressure plate. At high speed, when the power transmission is high the weights fly off and levers exert pressure on the plate which keeps the clutch firmly engaged. Thus instead of having more stiff springs for keeping the clutch engaged firmly at high speeds, they are less stiff, so that the driver may not get any strain in operating the clutch.

when the speed decreases, the weights fall and the levers do not exert any pressure on the pressure plate. Only the spring pressure is exerted on the pressure plate which is sufficient to keep the clutch engaged.

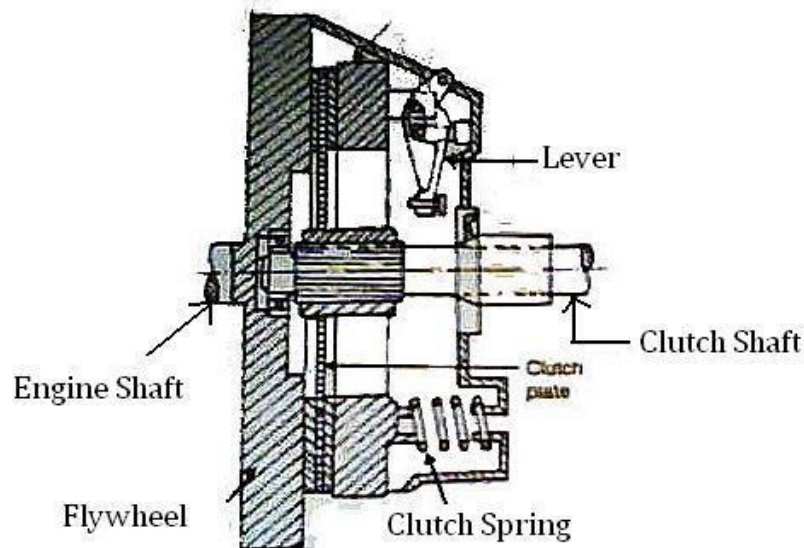

Fig: Semicentrifugal Clutch

3.2.6. Electromagnetic Clutch:

An electromagnetic clutch is a clutch (a mechanism for transmitting rotation) that is engaged and disengaged by an electromagnetic actuator. In this type of clutch, the flywheel consists of winding. The current is supplied to the winding from battery or dynamo.

When the current passes through the winding it produces an electromagnetic field which attracts the pressure plate, thereby engaging the clutch. When supply is cutoff, the clutch is disengaged. The gear lever consists of a clutch release switch. When then the driver holds the gear lever to change the gear the witch is operated cutting off the current to the winding which causes the clutch disengaged. At low speeds when the dynamo output is low, the clutch is not firmly engaged.

Therefore three springs are also provided on the pressure plate which helps the clutch engaged firmly at low speed also. Cycling is achieved by turning the voltage/current to the electromagnet on and off. Slippage normally occurs only during acceleration. When the clutch is fully engaged, there is no relative slip, assuming the clutch is sized properly, and thus torque transfer is 100% efficient.

The electromagnetic clutch is most suitable for remote operation since no linkages are required to control its engagement. It has fast, smooth operation. However, because energy dissipates as heat in the electromagnetic actuator every time the clutch is engaged, there is a risk of overheating. Consequently the maximum operating temperature of the clutch is limited by the temperature rating of the insulation of the electromagnet. This is a major limitation. Another disadvantage is higher initial cost.

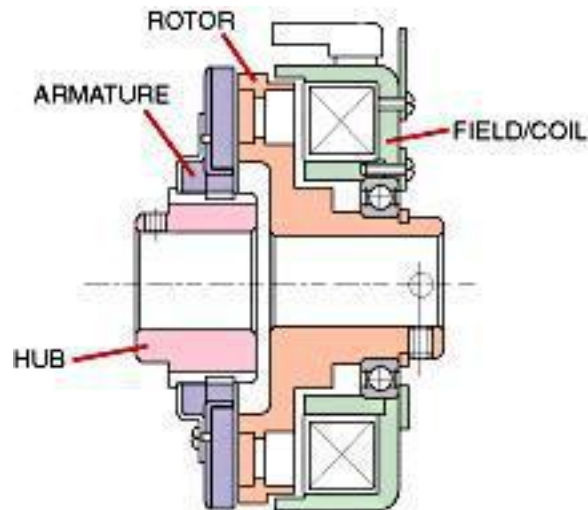

Fig: Electromagnetic Clutch

3.3. Gear Box;

A gearbox is a mechanical method of transferring energy from one device to another and is used to increase torque while reducing speed. Torque is the power generated through the bending or twisting of a solid material. This term is often used interchangeably with transmission. Located at the junction point of a power shaft, the gearbox is often used to create a right angle change in direction, as is seen in a rotary mower or a helicopter. Each unit is made with a specific purpose in mind, and the gear ratio used is designed to provide the level of force required. This ratio is fixed and cannot be changed once the box is constructed. The only possible modification after the fact is an adjustment that allows the shaft speed to increase, along with a corresponding reduction in torque. In a situation where multiple speeds are needed, a transmission with multiple gears can be used to increase torque while slowing down the output speed. This design is commonly found in automobile transmissions. The same principle can be used to create an overdrive gear that increases output speed while decreasing torque.

Principle of Gearing

Consider a simple 4-gear train. It consists of a driving gear A on input shaft and a driven gear D on the output shaft. In between the two gears there are two intermediate gears B, C. Each of these gears are mounted on separate shaft. We notice that:

Gear A drives Gear B

$$\therefore \frac{N_b}{N_a} = \frac{T_a}{T_b}$$

Gear B drives Gear C

$$\therefore \frac{N_c}{N_b} = \frac{T_b}{T_c}$$

Gear C drives Gear D

$$\therefore \frac{N_d}{N_c} = \frac{T_c}{T_d}$$

Therefore, the over all speed ratios are:

$$\therefore \frac{N_d}{N_a} = \frac{T_c}{T_d} \times \frac{T_b}{T_c} \times \frac{T_a}{T_b} = \frac{T_a}{T_d}$$

3.3.1. Types of Gear Boxes: The following types of gear box are used in automobiles:

- Sliding Mesh
- Constant Mesh
- Synchromesh.

3.3.1. Sliding Mesh Gear Box

It is the simplest gear box. The following figure shows 4-speed gear box in neutral position. 4 gears are connected to the lay shaft/counter shaft. A reverse idler gear is mounted on another shaft and always remains connected to the reverse gear of countershaft. This “H” shift pattern enables the driver to select four different gear ratios and a reverse gear.

Gears in Neutral:

When the engine is running and clutch is engaged the clutch shaft gear drives the countershaft gear. The countershaft rotates opposite in direction of the clutch shaft. In neutral position only the clutch shaft gear is connected to the countershaft gear. Other gears are free and hence the transmission main shaft is not turning. The vehicle is stationary.

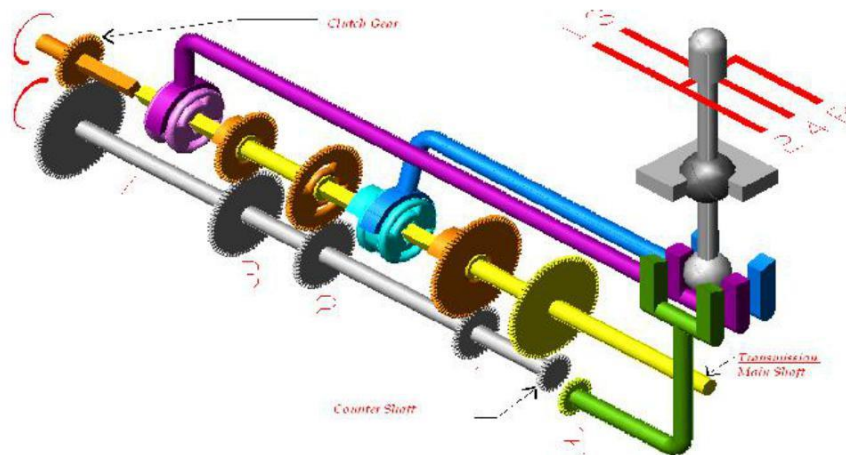
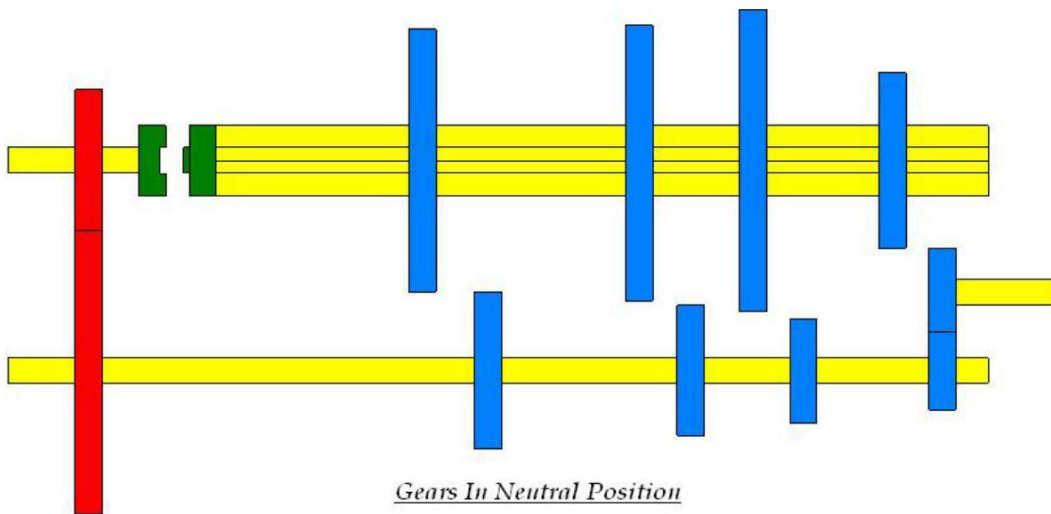

First or low shaft gear:

By operating the gear shift lever the larger gear on the main shaft is moved along the shaft to mesh with the first gear of the countershaft. The main shaft turns in the same direction as that of the clutch shaft. Since the smaller countershaft is engaged with larger shaft gear a gear reduction of approximately 4:1 is obtained i.e. the clutch shaft turns 4 times for each revolution of main shaft.

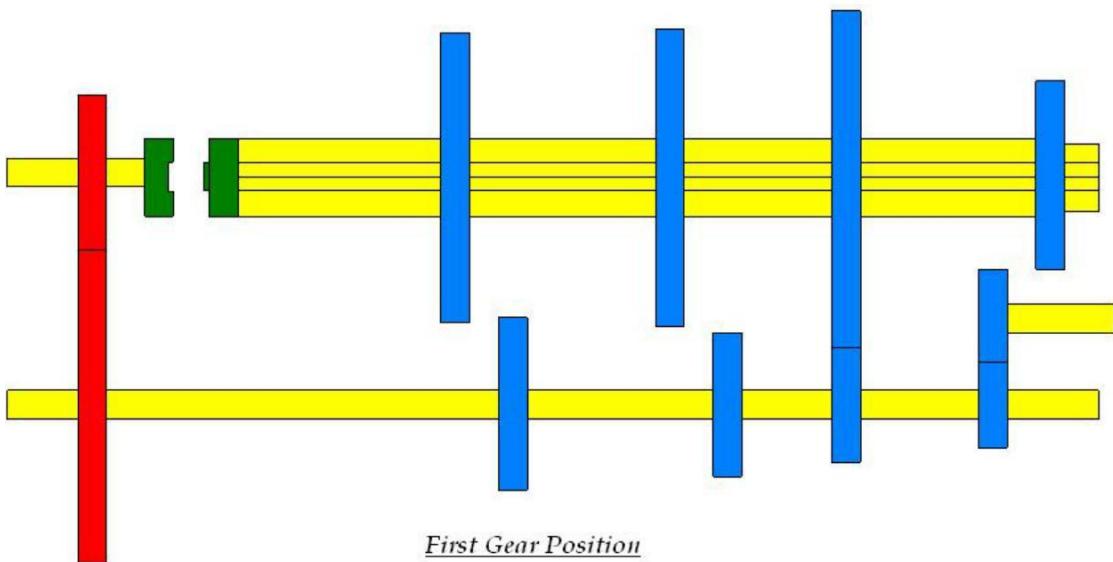
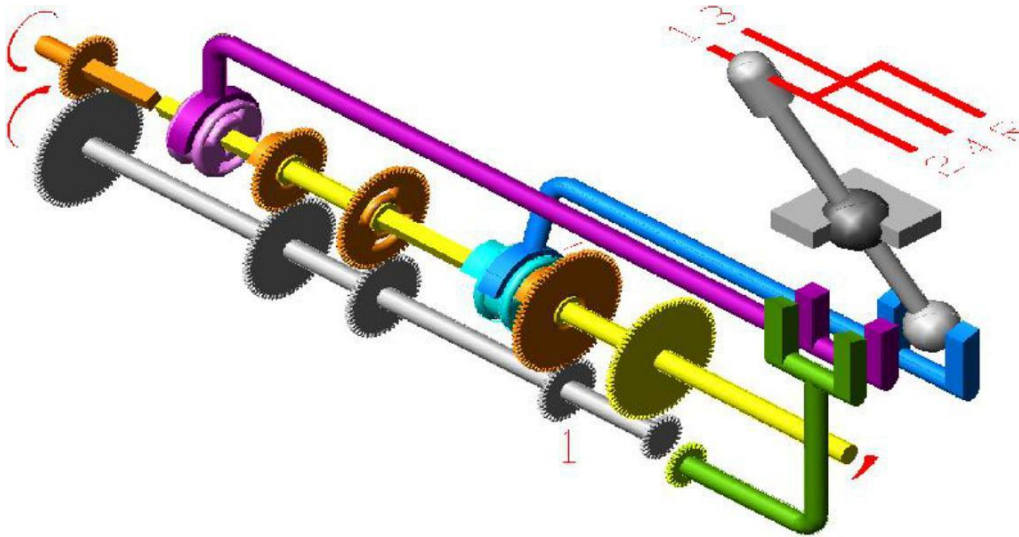

Second speed gear:

By operating the gear shift lever the third gear on the main shaft is moved along the shaft to mesh with the third gear of the counter shaft. The main shaft turns in same direction as clutch shaft. A gear reduction of approximately 3:1 is obtained.

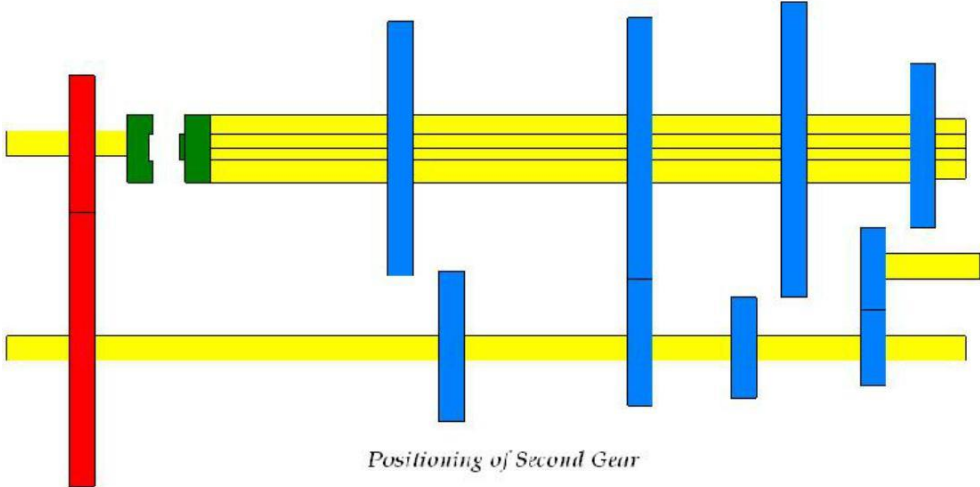
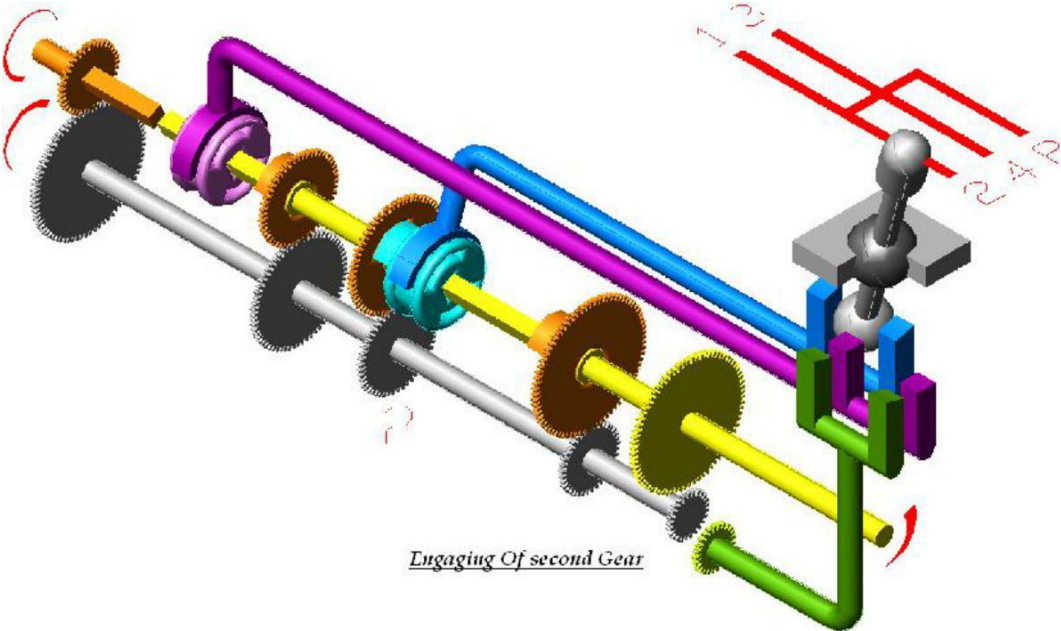

Third speed gear:

By operating the gear shift lever, the second gear of the main shaft and countershaft are demeshed and then the third gear of the main shaft are forced axially against the clutch shaft gear. External Teeth on the clutch shaft gear mesh with the internal teeth in the third and top gear. The main shaft turns in same direction as clutch shaft. A gear reduction of approximately 2:1 is obtained i.e. the clutch shaft turns 2 times for each revolution of main shaft.

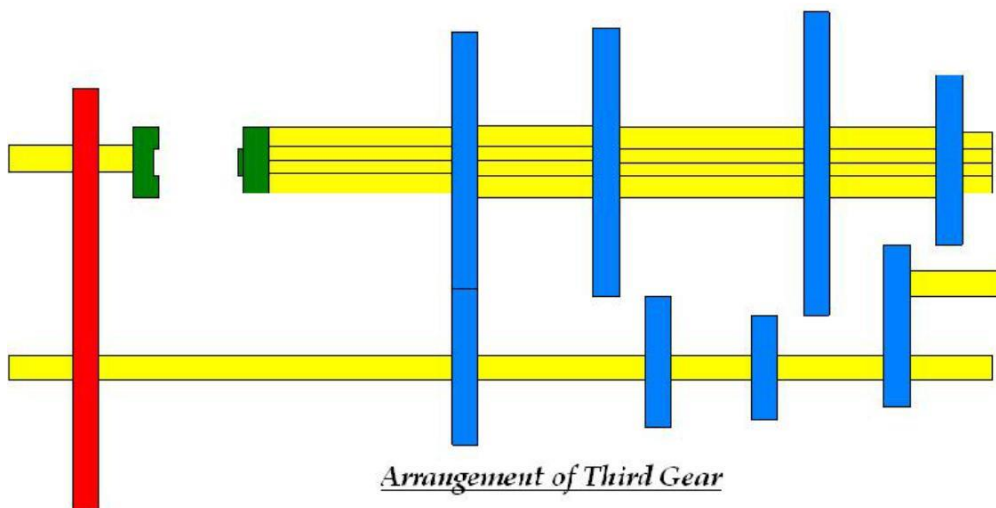
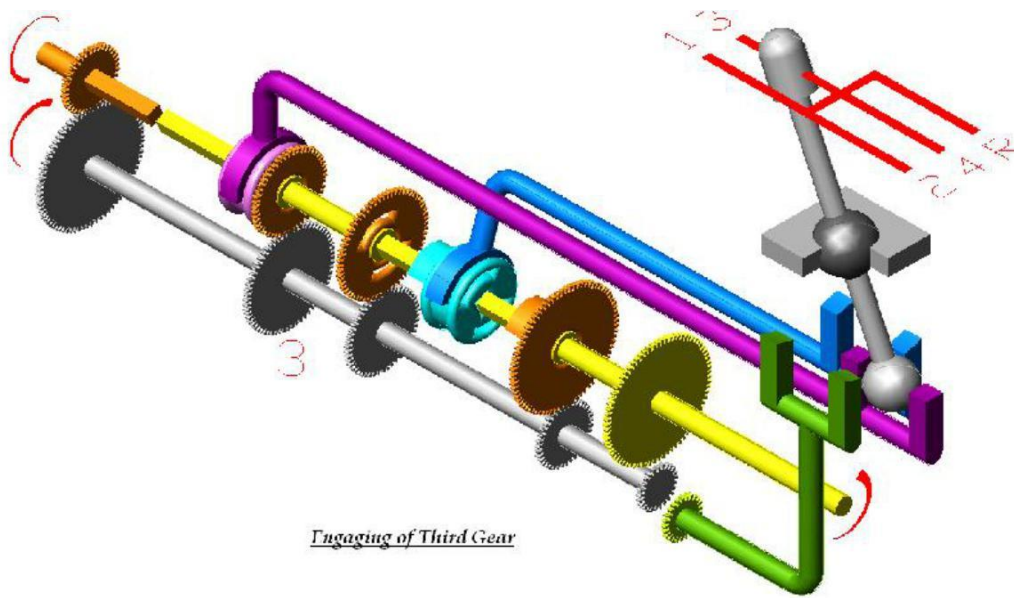

Fourth speed gear/ Top or High-Speed Gear:

By operating the gear shaft lever the third gears of the main and countershaft is demeshed and the gears present on the main shaft along with the shaft is forced axially against the clutch shaft gear. External teeth present on the main shaft engage with the internal teeth present on the main shaft. The main shaft turns along with the clutch shaft and a gear ratio of approximately 1:1 is obtained.

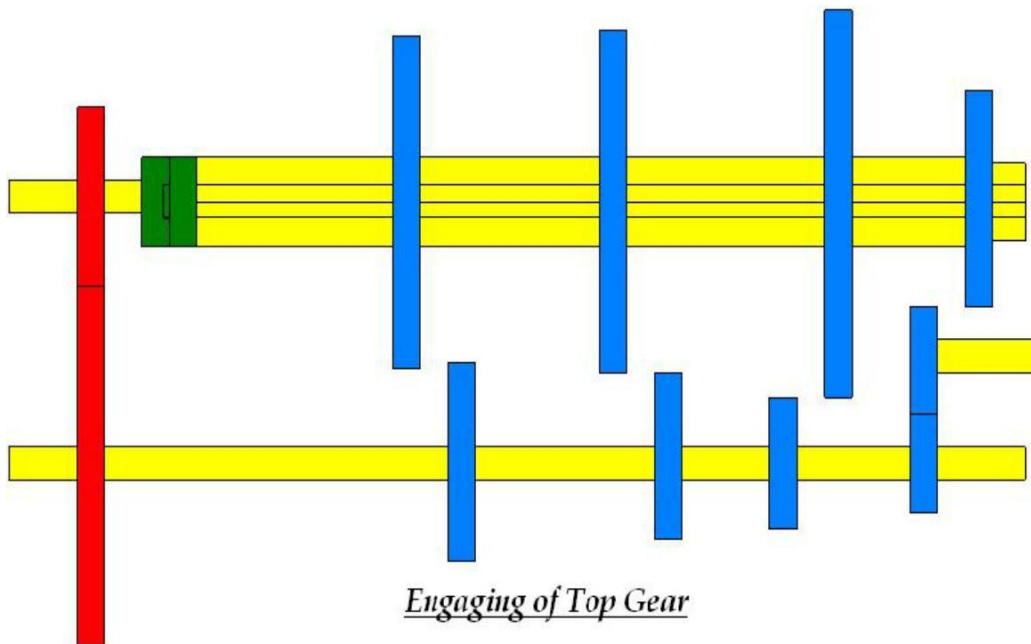
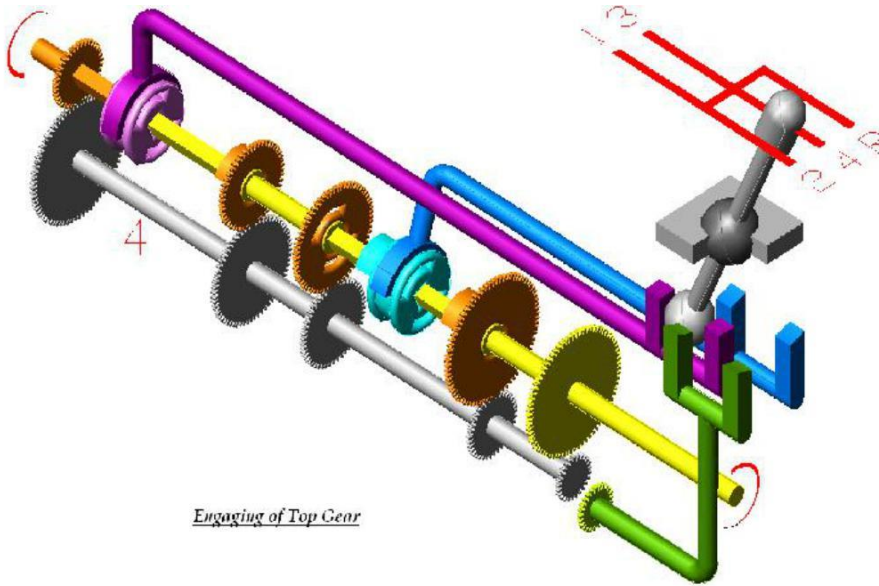

Reverse gear:

By operating the gear shift lever, the last gear present on the main shaft is engaged with the reverse idler gear. The reverse idler gear is always in mesh with the countershaft gear. Interposing the idler gear between the counter-shaft reverse gear and main shaft gear, the main shaft turns in the direction opposite to the clutch shaft. This reverses the rotation of the wheels so that the wheel backs.

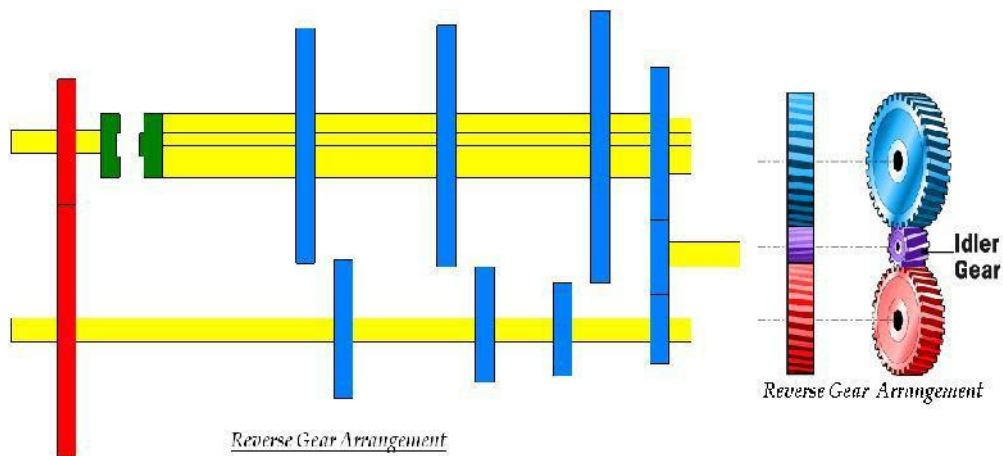
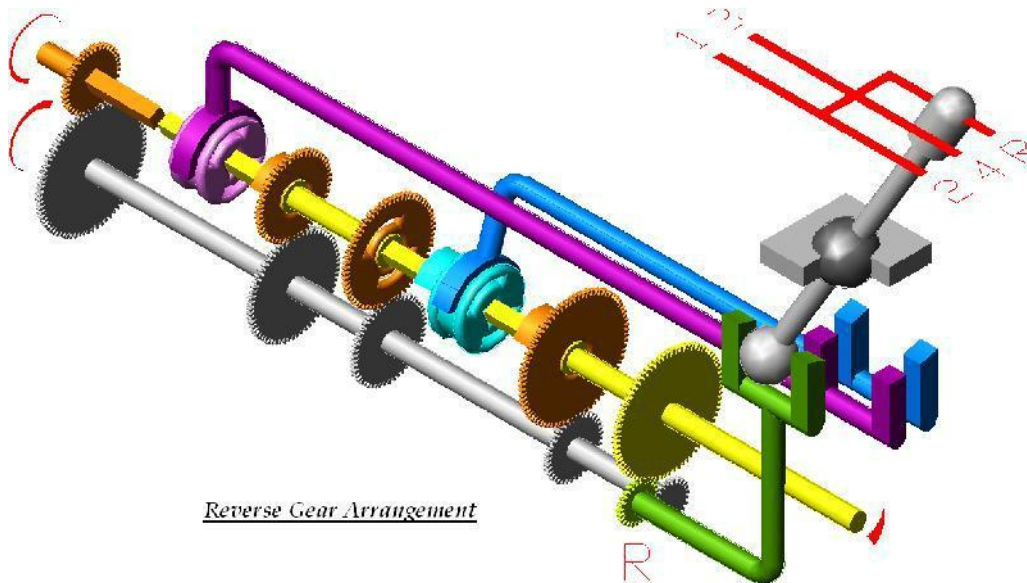

3.3.2. Constant Mesh Gear Box:

In this type of gear box, all gears of the main shaft are in constant mesh with the corresponding gears of the countershaft (Lay shaft). Two dog clutches are provided on the main shaft- one between the clutch gear and the second gear, and the other between the first gear and reverse gear. The main shaft is splined and all the gears are free on it. Dog clutch can slide on the shaft and rotates with it. All the gears on the countershaft are rigidly fixed with it.

When the left hand dog clutch is made to slide to the left by means of the gear shift lever, it meshes with the clutch gear and the top speed gear is obtained. When the left hand dog clutch meshes with the second gear, the second speed gear is obtained. Similarly by sliding the right hand dog clutch to the left and right, the first speed gear and reverse gear are obtained respectively. In this gear box because all the gears are in constant mesh they are safe from being damaged and an unpleasant grinding sound does not occur while engaging and disengaging them.

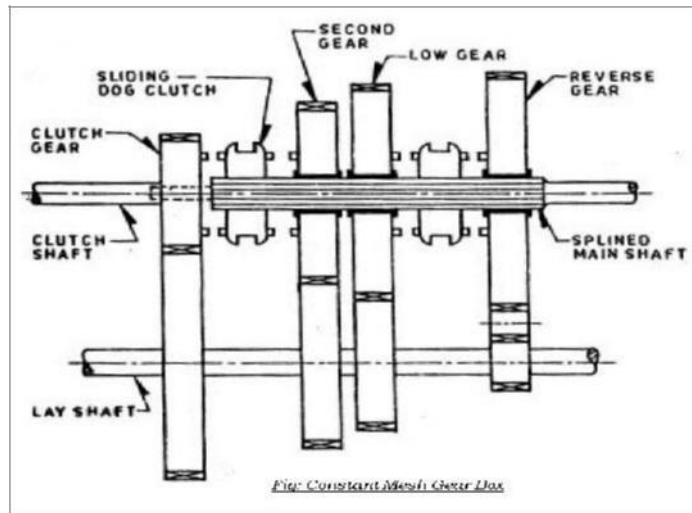

3.3.3. Synchromesh Gear Box:

In sliding Mesh Gear box the two meshing gears need to be revolve at equal peripheral speeds to achieve a jerk less engagement and it is true for constant mesh gear box in which the peripheral speeds of sliding dog and the corresponding gear on the output shaft must be equal. The peripheral speed is given by $V = \frac{\pi d N}{60}$ Where d_1 and N_1 are pitch circle diameter and r.p.m. of gear and d_2 and N_2 diameter and r.p.m. of attached dog respectively. Now $N_1 \neq N_2$ since $d_1 \neq d_2$. Thus there is a difference in gear and dog which necessitates double declutching. The driver has to disengage the clutch twice in quick succession therefore it is referred as double declutching. There are two steps involved in this process:

The clutch is disengaged i.e. first declutching and the gear system is placed in its neutral position. Now the clutch is reengaged and acceleration pedal is pressed to adjust the engine speed according to driver's judgment. The clutch is disengaged (i.e. second declutching) again the appropriate gear is engaged and then the clutch is reengaged

It is that gear box in which sliding synchronizing units are provided in place of sliding dog clutches as in case of constant mesh gear box. With the help of synchronizing unit, the speed of both the driving and driven shafts is synchronized before they are clutched together through train of gears. The arrangement of power flow for the various gears remains the same as in constant mesh gear box. The synchronizer is made of frictional materials. When the collar tries to mesh with the gear, the synchronizer will touch the gear first and use friction force to drive the gear to spin at the same speed as the collar. This will ensure that the collar is meshed into the gear very smoothly without grinding. Synchronesh gear devices work on the principle that two gears to be engaged are first brought into frictional contact which equalizes their speed after which they are engaged readily and smoothly.

The following types of devices are mostly used in vehicles:

- Pin Type
- Synchronizer ring type

A synchronizing system is used for smooth meshing. Synchronesh works like a friction clutch. In the following figure two conical surfaces cone-1 is the part of the collar and the cone-2 is the part of the gear wheel. Cone1, 2 are revolving at different speeds. While cone-2 is revolving, cone-1 gradually slides into it. Friction slows or speeds up the gear wheel. Finally both the cones revolve at same speed.

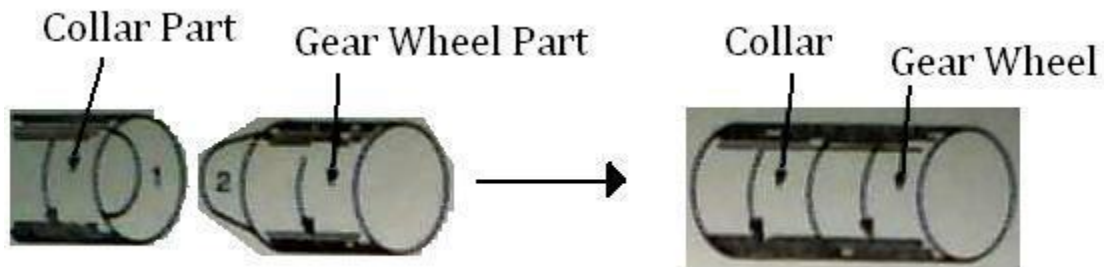

Fig: Two Cones acting as Friction Clutch

The following Fig collar and gear wheel are separate and they are revolving at different speeds. The internal cone comes in contact with the outer cone of the gear wheel. Friction slows or speeds up the gear wheel.

And when the collar and gear wheel rotate at same speed the spring loaded outer ring of the collar is pushed forward. The dog slide smoothly into mesh without clashing. The collar and gear wheel lock and revolve at same speed. This the principle of synchronesh.

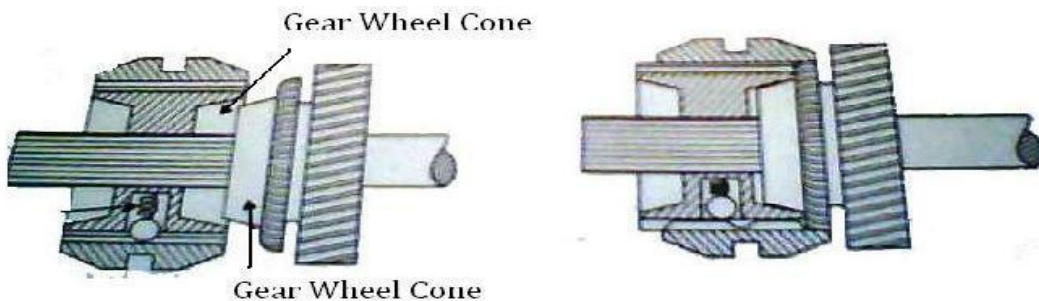

Fig: Synchro Mesh Unit

3.4. U- Joint:

A universal joint, U-joint, Cardan joint, Hardy-Spicer joint, or Hooke's joint is a linkage that transmits rotation between two non parallel shafts whose axes are coplanar but not coinciding., and is commonly used in shafts that transmit rotary motion. It is used in automobiles where it is used to transmit power from the gear box of the engine to the rear axle. The driving shaft rotates at a uniform angular speed, where as the driven shaft rotates at a continuously varying angular speed.

A complete revolution of either shaft will cause the other to rotate through a complete revolution at the same time. Each shaft has fork at its end. The four ends of the two fork are connected by a centre piece, the arms of which rest in bearings, provided in fork ends. The centre piece can be of any shape of a cross, square or sphere having four pins or arms. The four arms are at right angle to each other.

When the two shafts are at an angle other than 180° (straight), the driven shaft does not rotate with constant angular speed in relation to the drive shaft; the more the angle goes toward 90° the jerkier the movement gets (clearly, when the angle $\beta = 90^\circ$ the shafts would even lock). However, the overall average speed of the driven shaft remains the same as that of driving shaft, and so speed ratio of the driven to the driving shaft on average is 1:1 over multiple rotations.

The angular speed ω_2 of the driven shaft, as a function of the angular speed of the driving shaft ω_1 and the angle of the driving shaft ϕ_1 , is found using:

$$\omega_2 = \omega_1 \cos\alpha / (1 - \sin^2\alpha \cdot \cos^2\theta)$$

For a given and set angle between the two shafts it can be seen that there is a cyclical variation in the input to output velocity ratio. Maximum values occur when $\sin \theta = 1$, i.e. when $\theta = 90^\circ$ and 270° . The denominator is greatest when $\theta = 0^\circ$ or 180° and this condition gives the minimum ratio of the velocities.

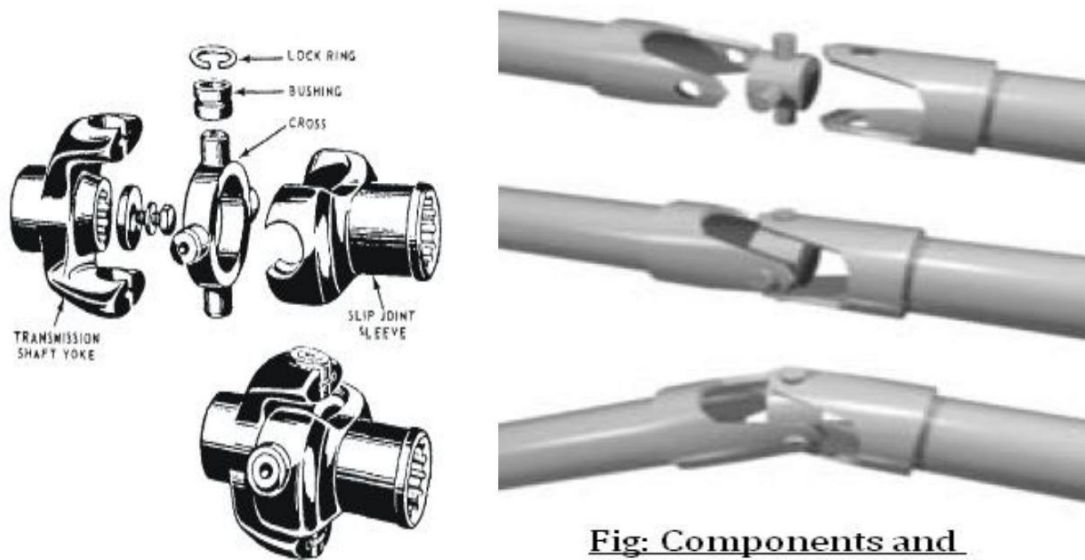
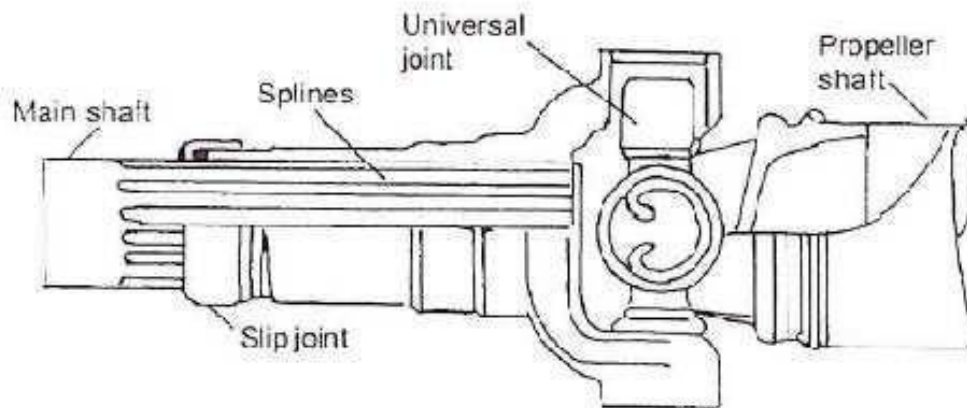

Fig: Components and assembly of U-Joint

Components of Hooke's Joint

Slip Joint in the Propeller Shaft;



Hook Joint in the Propeller Shaft;

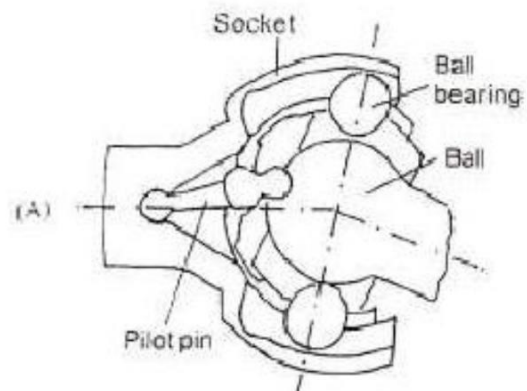
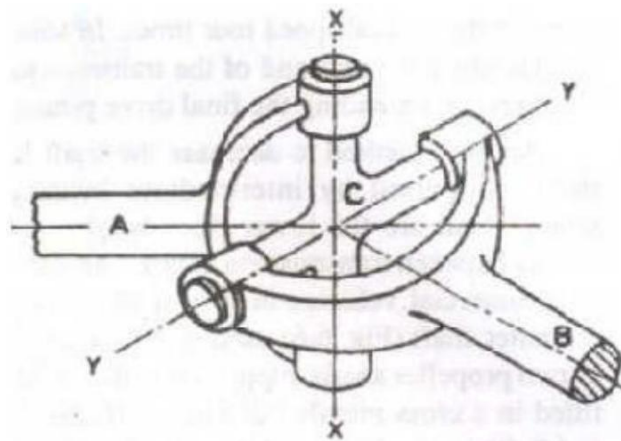

3.5. The Drive Shaft

The drive shaft, or propeller shaft, connects the transmission output shaft to the differential pinion shaft. Since all roads are not perfectly smooth, and the transmission is fixed, the drive shaft has to be flexible to absorb the shock of bumps in the road. Universal, or "U-joints" allow the drive shaft to flex (and stop it from breaking) when the drive angle changes.

Drive shafts are usually hollow in order to weigh less, but of a large diameter so that they are strong. High quality steel, and sometimes aluminum are used in the manufacture of the drive shaft. The shaft must be quite straight and balanced to avoid vibrating. Since it usually turns at engine speeds, a lot of damage can be caused if the shaft is unbalanced, or bent. Damage can also be caused if the U-joints are worn out.

There are two types of drive shafts, the Hotchkiss drive and the Torque Tube Drive. The Hotchkiss drive is made up of a drive shaft connected to the transmission output shaft and the differential pinion gear shaft. U-joints are used in the front and rear. The Hotchkiss drive transfers the torque of the output shaft to the differential. No wheel drive thrust is sent to the drive shaft. Sometimes this drive comes in two pieces to reduce vibration and make it easier to install (in this case, three U-joints are needed). The two-piece types need ball bearings in a dustproof housing as center support for the shafts. Rubber is added into this arrangement for noise and vibration reduction.

The torque tube drive shaft is used if the drive shaft has to carry the wheel drive thrust. It is a hollow steel tube that extends from the transmission to the rear axle housing. One end is fastened to the axle housing by bolts. The transmission end is fastened with a torque ball. The drive shaft fits into the torque tube. A U-joint is located in the torque ball, and the axle housing end is splined to the pinion gear shaft. Drive thrust is sent through the torque tube to the torque ball, to transmission, to engine and finally, to the frame through the engine mounts. That is, the car is pushed forward by the torque tube pressing on the engine.

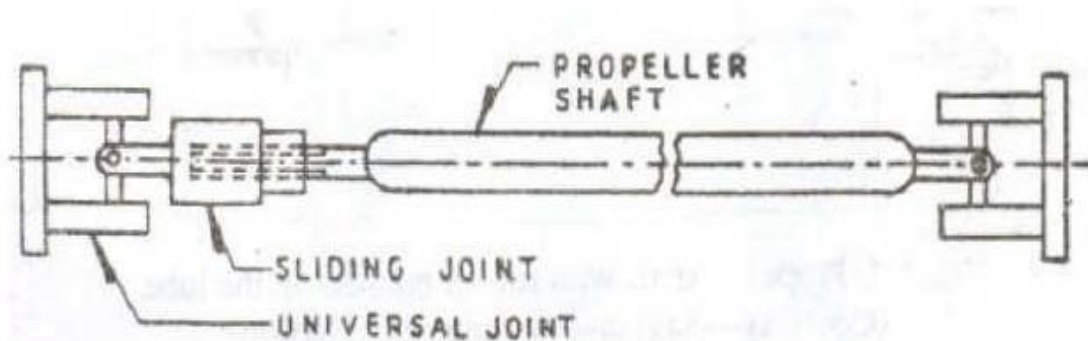

3.6. Differential Unit:

Differentials are a variety of gearbox, almost always used in one of two ways. In one of these, it receives one input and provides two outputs; this is found in every automobile. In automobile and other wheeled vehicles, the differential allows each of the driving wheels to rotate at different speeds, while supplying equal torque to each of them. In the other, less commonly encountered, it combines two inputs to create an output that is the sum (or difference) of the inputs. In automotive applications, the differential and its housing are sometimes collectively called a "pumpkin" (because the housing resembles a pumpkin).

Purpose:-

The differential gear box has following functions:

- Avoid skidding of the rear wheels on a road turning.
- Reduces the speed of inner wheels and increases the speed of outer wheels, while drawing a curve.
- Keeps equal speeds of all the wheels while moving on a straight road.
- Eliminates a single rigid rear axle, and provides a coupling between two rear axles.

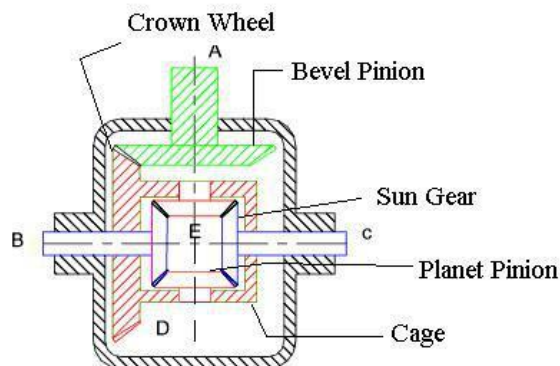

Fig: Differential gear Assembly

The following description of a differential applies to a "traditional" rear- or front-wheel-drive car or truck:

Power is supplied from the engine, via the transmission or gearbox, to a drive shaft termed as propeller shaft, which runs to the differential. A spiral bevel pinion gear at the end of the propeller shaft is encased within the differential itself, and it meshes with the large spiral bevel ring gear termed as crown wheel. The ring and pinion may mesh in hypoid orientation.

The ring gear is attached to a carrier, which holds what is sometimes called a spider, a cluster of four bevel gears in a rectangle, so each bevel gear meshes with two neighbors and rotates counter to the third that it faces and does not mesh with. Two of these spider gears are aligned on the same axis as the ring gear and drive the half shafts connected to the vehicle's driven wheels.

These are called the side gears. The other two spider gears are aligned on a perpendicular axis which changes orientation with the ring gear's rotation. These two gears are just called pinion gears, not to be confused with the main pinion gear. (Other spider designs employ different numbers of pinion gears depending on durability requirements.)

As the carrier rotates, the changing axis orientation of the pinion gears imparts the motion of the ring gear to the motion of the side gears by pushing on them rather than turning against them (that is, the same teeth stay in contact), but because the spider gears are not restricted from turning against each other, within that motion the side gears can counter-rotate relative to the ring gear and to each other under the same force (in which case the same teeth do not stay in contact).

Thus, for example, if the car is making a turn to the right, the main ring gear may make 10 full rotations. During that time, the left wheel will make more rotations because it has further to travel, and the right wheel will make fewer rotations as it has less distance to travel. The side gears will rotate in opposite directions relative to the ring gear by, say, 2 full turns each (4 full turns relative to each other), resulting in the left wheel making 12 rotations, and the right wheel making 8 rotations.

The rotation of the ring gear is always the average of the rotations of the side gears. This is why if the wheels are lifted off the ground with the engine off, and the drive shaft is held (preventing the ring gear from turning inside the differential), manually rotating one wheel causes the other to rotate in the opposite direction by the same amount.

When the vehicle is traveling in a straight line, there will be no differential movement of the planetary system of gears other than the minute movements necessary to compensate for slight differences in wheel diameter, undulations in the road (which make for a longer or shorter wheel path), etc.

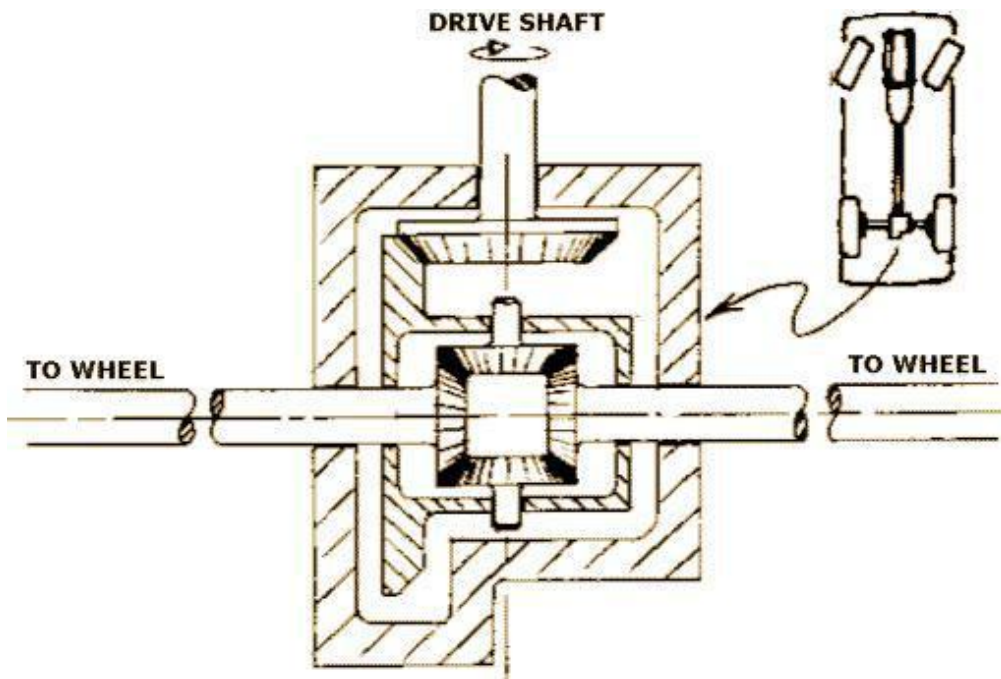

3.8. Automatic Transmission:

An automatic transmission (commonly "AT" or "Auto") is an automobile gearbox that can change gear ratios automatically as the vehicle moves, freeing the driver from having to shift gears manually.

Automatic Transmission Modes:

In order to select the mode, the driver would have to move a gear shift lever located on the steering column or on the floor next to him/her. In order to select gears/modes the driver must push a button in (called the shift lock button) or pull the handle (only on column mounted shifters) out. In some vehicles position selector buttons for each mode on the cockpit instead, freeing up space on the central console. Vehicles conforming to U.S. Government standards must have the modes ordered P-R-N-D-L (left to right, top to bottom, or clockwise). Prior to this, quadrant-selected automatic transmissions often utilized a P-N-D-L-R layout, or similar. Such a pattern led to a number of deaths and injuries owing to un-intentional gear miss-selection, as well the danger of having a selector (when worn) jump into Reverse from Low gear during engine braking maneuvers.

Automatic Transmissions have various modes depending on the model and make of the transmission. Some of the common modes are:

Park Mode (P):-

This selection mechanically locks the transmission, restricting the car from moving in any direction. A parking pawl prevents the transmission—and therefore the vehicle—from moving, although the vehicle's non-drive wheels may still spin freely. For this reason, it is recommended to use the hand brake (or parking brake) because this actually locks the (in most cases, rear) wheels and prevents them from moving. This also increases the life of the transmission and the park pin mechanism, because parking on an incline with the transmission in park without the parking brake engaged will cause undue stress on the parking pin. An efficiently-adjusted hand brake should also prevent the car from moving if a worn selector accidentally drops into reverse gear during early morning fast-idle engine warm ups.

Reverse (R):-

This puts the car into the reverse gear, giving the ability for the car to drive backwards. In order for the driver to select reverse they must come to a complete stop, push the shift lock button in (or pull the shift lever forward in the case of a column shifter) and select reverse. Not coming to a complete stop can cause severe damage to the transmission. Many modern automatic gearboxes have a safety mechanism in place, which does to some extent prevent (but doesn't completely avoid) inadvertently putting the car in reverse when the vehicle is moving.

This mechanism usually consists of a solenoid-controlled physical barrier on either side of the Reverse position, which is electronically engaged by a switch on the brake pedal. Therefore, the brake pedal needs to be depressed in order to allow the selection of reverse. Some electronic transmissions prevent or delay engagement of reverse gear altogether while the car is moving.

Neutral/No gear (N):-

This disconnects the transmission from the wheels so the car can move freely under its own weight. This is the only other selection in which the car can be started.

Drive (D):-

This allows the car to move forward and accelerate through its range of gears. The number of gears a transmission has depends on the model, but they can commonly range from 3, 4 (the most common), 5, 6 (found in VW/Audi Direct Shift Gearbox), 7 (found in Mercedes 7G gearboxes, BMW M5 and VW/Audi Direct Shift Gearbox) and 8 in the newer models of Lexus cars. Some cars when put into D will automatically lock the doors or turn on the Daytime Running Lamps.

Overdrive ([D], Od, Or A Boxed D):-

This mode is used in some transmissions to allow early Computer Controlled Transmissions to engage the Automatic Overdrive. In these transmissions, Drive (D) locks the Automatic Overdrive off, but is identical otherwise. OD (Overdrive) in these cars is engaged under steady speeds or low acceleration at approximately 35-45 mph (approx. 72 km/h). Under hard acceleration or below 35-45 mph, the transmission will automatically downshift. Vehicles with this option should be driven in this mode unless circumstances require a lower gear.

Second (2 or S):-

This mode limits the transmission to the first two gears, or more commonly locks the transmission in second gear. This can be used to drive in adverse conditions such as snow and ice, as well as climbing or going down hills in the winter time. Some vehicles will automatically up-shift out of second gear in this mode if a certain rpm range is reached, to prevent engine damage.

First (1 or L):-

This mode locks the transmission in first gear only. It will not accelerate through any gear range. This, like second, can be used during the winter season, or for towing.

As well as the above modes there are also other modes, dependent on the manufacturer and model. Some examples include:

D5:- In Hondas and Acuras equipped with 5-speed automatic transmissions, this mode is used commonly for highway use (as stated in the manual), and uses all five forward gears.

D4:- This mode is also found in Honda and Acura 4 or 5-speed automatics and only uses the first 4 gears. According to the manual, it is used for "stop and go traffic", such as city driving.

D3:- This mode is found in Honda and Acura 4-speed automatics and only uses the first 3 gears. According to the manual, it is used for stop & go traffic, such as city driving. This mode is also found in Honda and Acura 5-speed automatics.

This is the manual selection of gears for automatics, such as Porsche's Tiptronic. This feature can also be found in Chrysler and General Motors products such as the Dodge Magnum and Pontiac G6. The driver can shift up and down at will, by toggling the shift lever (console mounted) like a semi-automatic transmission. This mode may be engaged either through a selector/position or by actually changing gear (e.g. tipping the gear-down paddles mounted near the driver's fingers on the steering wheel).

The predominant form of automatic transmission is hydraulically operated, using a fluid coupling/ torque converter and a set of planetary gear-sets to provide a range of torque multiplication.

Parts And Operation:-

A hydraulic automatic transmission consists of the following parts:

- Torque Converter/Fluid Coupling
- Planetary Gear Set
- Clutch packs & Bands
- Valve Body
- Hydraulic or Lubricating Oil

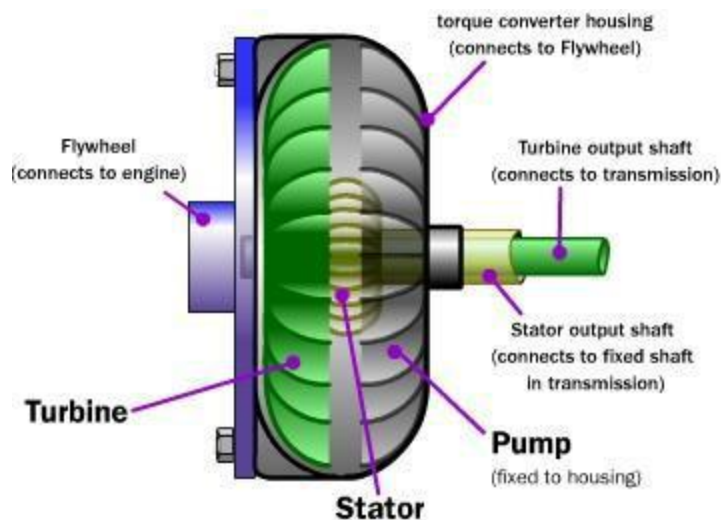

Fig: Cut section Model of Torque converter

Torque Converter/Fluid Coupling: -Unlike a manual transmission system, automatic transmission does not use a clutch to disconnect power from the engine temporarily when shifting gears. Instead, a device called a torque converter was invented to prevent power from being temporarily disconnected from the engine and also to pre-vent the vehicle from stalling when the transmission is in gear.

A fluid coupling/torque converter consists of a sealed chamber containing two toroidal-shaped, vaned components, the pump and turbine, immersed in fluid (usually oil). The pump or driving torus (the latter a General Motors automotive term) is rotated by the prime mover, which is typically an internal combustion engine or electric motor. The pump's motion imparts a relatively complex centripetal motion to the fluid. Simplified, this is a centrifugal force that throws the oil outwards against the coupling's housing, whose shape forces the flow in the direction of the turbine or driven torus (the latter also a General Motors term).

Here, Coriolis force reaction transfers the angular fluid momentum outward and across, applying torque to the turbine, thus causing it to rotate in the same direction as the pump. The fluid leaving the center of the turbine returns to the pump, where the cycle endlessly repeats. The pump typically is connected to the flywheel of the engine—in fact, the coupling's enclosure may be part of the flywheel proper, and thus is turned by the engine's crankshaft. The turbine is connected to the input shaft of the transmission. As engine speed increases while the transmission is in gear, torque is transferred from the engine to the input shaft by the motion of the fluid, propelling the vehicle. In this regard, the behavior of the fluid coupling strongly resembles that of a mechanical clutch driving a manual transmission.

A torque converter differs from a fluid coupling in that it provides a variable amount of torque multiplication at low engine speeds, increasing "breakaway" acceleration. This is accomplished with a third member in the "coupling assembly" known as the stator, and by altering the shapes of the vanes inside the coupling in such a way as to curve the fluid's path into the stator. The stator captures the kinetic energy of the transmission fluid in effect using the left-over force of it to enhance torque multiplication.

Tiptronic transmission is a special type of automatic transmission with a computer controlled automatic shift. The driver can switch the transmission to manual mode, which lets her shift the gear at her wish sequentially up (+) or down (-) without disengaging the clutch. This works just like a manual transmission; however, it still uses a torque converter to transfer power from the engine. Unfortunately, this is less efficient than a manual transmission.

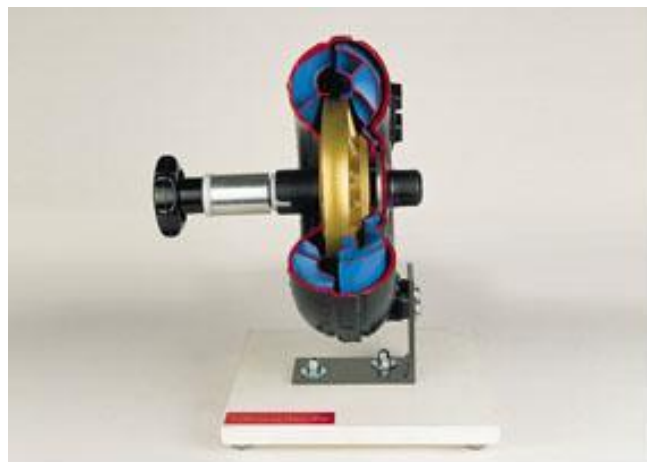

Fig: Torque converter

Planetary Gear-Set: - The automatic system for current automobiles uses a planetary gear set instead of the traditional manual transmission gear set. The planetary gear set contains four parts: sun gear, planet gears, planet carrier, and ring gear. Based on this planetary set design, sun gear, planet carrier, and ring gear spin centrifugally. By locking one of them, the planetary set can generate three different gear ratios, including one reverse gear, without engaging and disengaging the gear set. The gear set is actuated by hydraulic servos controlled by the valve body, providing two or more gear ratios.

Clutch Packs And Bands: - A clutch pack consists of alternating disks that fit inside a clutch drum. Half of the disks are steel and have splines that fit into grooves on the inside of the drum. The other half have a friction material bonded to their surface and have splines on the inside edge that fit grooves on the outer surface of the adjoining hub. There is a piston inside the drum that is activated by oil pressure at the appropriate time to squeeze the clutch pack together so that the two components become locked and turn as one.

The other half have a friction material bonded to their surface and have splines on the inside edge that fit grooves on the outer surface of the adjoining hub. There is a piston inside the drum that is activated by oil pressure at the appropriate time to squeeze the clutch pack together so that the two components become locked and turn as one.

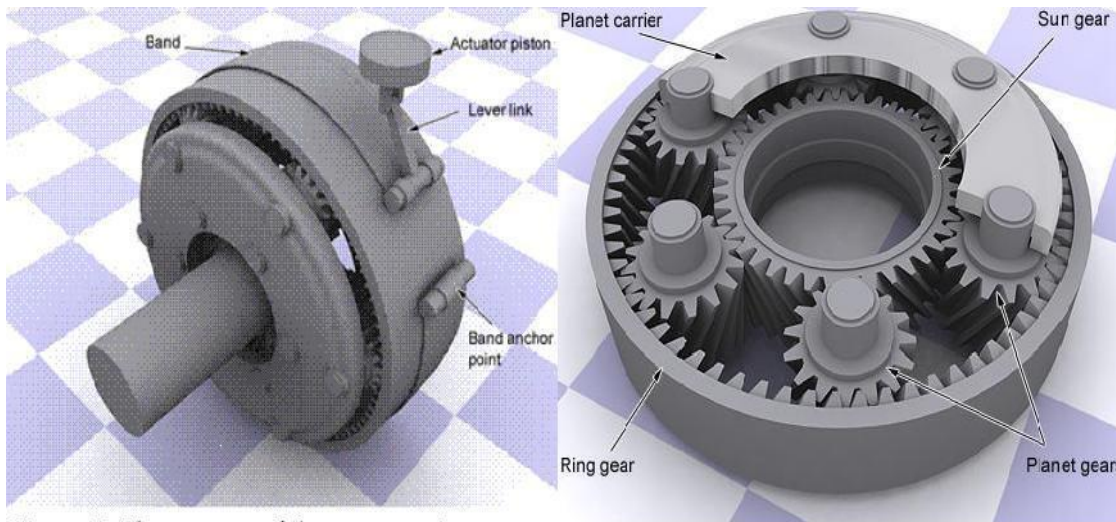

Figure 12: The structure of the actuator piston, lever link, and band system.

Figure 10 Planetary Gear Set.

A band is a steel strap with friction material bonded to the inside surface. One end of the band is anchored against the transmission case while the other end is connected to a servo. At the appropriate time hydraulic oil is sent to the servo under pressure to tighten the band around the drum to stop the drum from turning.

The bands come into play for manually selected gears, such as low range or reverse, and operate on the planetary drum's circumference. Bands are not applied when drive/overdrive range is selected, the torque being transmitted by the sprag clutches instead.

The sun gear is connected to a drum, which can be locked by a band. The ring gear is directly connected to the input shaft, which transfers power from the engine. The planet carrier is connected to the output shaft, which transfers power into the wheels.

Based on this design, when in neutral, both band and clutch sets are released. Turning the ring gear can only drive planet gears but not the planet carrier, which stays static if the car is not moving. The planet gears drive the sun gear to spin freely. In this situation, the input shaft is not able to transfer power to the output shaft. When shifting to 1st gear, the band locks the sun gear by locking the drum. The ring gear drives the planet carrier to spin. In this situation, the ring gear (input shaft) spins faster than the planet carrier (output shaft).

To shift to higher gear, the band is released and the clutch is engaged to force the sun gear and planet carrier (output shaft) to spin at the same speed. The input shaft will also spin at the same speed as the output shaft, which makes the car run faster than in 1st gear. Using a compound planetary gear set generates more gear ratios with a special gear ratio, over-drive gear whose gear ratio is small than 1.

This will make the gear shift smoother. Both the band and clutch piston are pressurized by the hydraulic system. The part connecting the band or clutches to the hydraulic system is called the shift valve, while the one connecting the hydraulic system to the output shaft is called the governor.

The governor is a centrifugal sensor with a spring loaded valve. The faster the governor spins, the more the valve opens. The more the valve opens, the more the fluid goes through and the higher the pressure applied on the shift valve. Therefore, each band and clutch can be pushed to lock the gear based on a specific spin speed detected by the governor from the output shaft. To make the hydraulic system work efficiently, a complex maze of passages was designed to replace a large number of tubes. For modern cars, an electronic con-trolled (computer controlled) solenoid pack is used to detect throttle position, vehicle speed, engine speed, engine load, brake pedal position, etc., and to automatically choose the best gear for a moving vehicle.

Principally, a type of device known as a sprag or roller clutch is used for routine upshifts/downshifts. Operating much as a ratchet, it transmits torque only in one direction, freewheeling or "overrunning" in the other. The advantage of this type of clutch is that it eliminates the sensitivity of timing a simultaneous clutch release/apply on two planetaries, simply "taking up" the drivetrain load when actuated, and releasing automatically when the next gear's sprag clutch assumes the torque transfer.

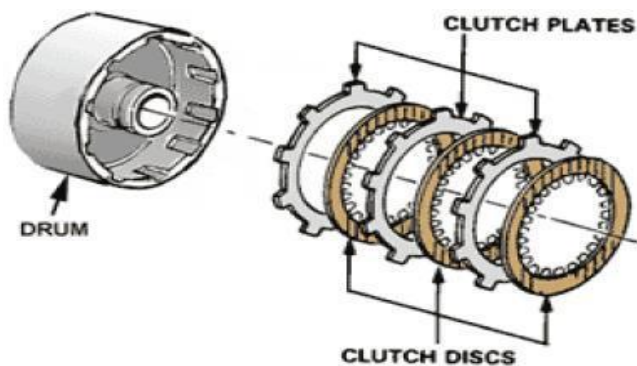

Fig: CLUTCH PACKS

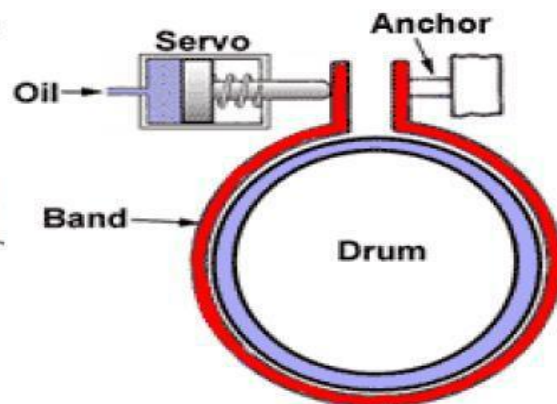
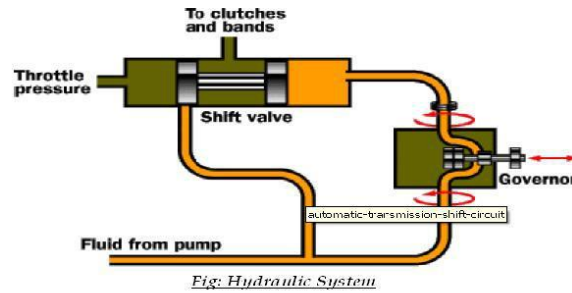

Fig: BANDS



Valve Body: - Hydraulic control center that receives pressurized fluid from a main pump operated by the fluid coupling/torque converter. The pressure coming from this pump is regulated and used to run a network of spring-loaded valves, check balls and servo pistons.

The valves use the pump pressure and the pressure from a centrifugal governor on the output side (as well as hydraulic signals from the range selector valves and the throttle valve or modulator) to control which ratio is selected on the gearset; as the car and engine change speed, the difference between the pressures changes, causing different sets of valves to open and close.

Each of the many valves in the valve body has a specific purpose and is named for that function. For example the 2-3 shift valves activate the 2nd gear to 3rd gear up-shift or the 3-2 shift timing valve which determines when a downshift should occur.

The hydraulic pressure controlled by these valves drives the various clutch and brake band actuators, thereby controlling the operation of the planetary gearset to select the optimum gear ratio for the current operating conditions. However, in many modern automatic transmissions, the valves are controlled by electro-mechanical servos which are controlled by the Engine Management System or a separate transmission controller.

The most important valve and the one that you have direct control over is the manual valve. The manual valve is directly connected to the gear shift handle and covers and uncovers various passages depending on what position the gear shift is placed in. When you place the gear shift in Drive, for instance, the manual valve directs fluid to the clutch pack(s) that activates 1st gear.

It also sets up to monitor vehicle speed and throttle position so that it can determine the optimal time and the force for the 1 - 2 shifts. On computer controlled transmissions, you will also have electrical solenoids that are mounted in the valve body to direct fluid to the appropriate clutch packs or bands under computer control to more precisely control shift points.

Hydraulic & Lubricating Oil: - A component called Automatic Transmission Fluid (ATF) which is part of the transmission mechanism provides lubrication, corrosion prevention, and a hydraulic medium to convey mechanical power.

Primarily it is made of refined petroleum and processed to provide properties that promote smooth power transmission and increase service life. ATF is one of the parts of the automatic transmission that needs routine service as the vehicle ages.

3.9. Semi Automatic Transmission

A semi-automatic transmission (also known as clutch less manual transmission, automated manual transmission, e-gear, shift-tronic, flappy paddle gearbox, or paddle shift gearbox) is a system which uses electronic sensors, processors and actuators to do gear shifts on the command of the driver. This removes the need for a clutch pedal which the driver otherwise needs to depress before making a gear change, since the clutch itself is actuated by electronic equipment which can synchronize the timing and torque required to make gear shifts quick and smooth.

The system was designed by European automobile manufacturers to provide a better driving experience, especially in cities where congestion frequently causes stop-and-go traffic patterns. Like a tiptronic transmission, a semi-automatic transmission can also be switched to manual mode to perform gear shifting at the drivers wish.

The two most common semi-automatic transmissions

- Direct shift transmission (or dual-clutch transmission)
- Electro-hydraulic manual transmission (or sequential transmission)

Direct shift transmission: In direct shift transmission direct shift gear box is used. The Direct-Shift Gearbox or D.S.G. is an electronically controlled, twin-shaft dual-clutch manual gearbox, without a conventional clutch pedal, with full automatic or semi-manual control.

Unlike the conventional manual transmission system, there are two different gear/collar sets, with each connected to two different input/output shafts. The outer clutch pack drives gears 1, 3, 5 and reverse. It is just like two conventional manual transmission gear boxes in one. The inner clutch pack drives gears 2, 4, and 6. Instead of a standard large dry single-plate clutch, each clutch pack is a collection of four small wet interleaved clutch plates.

Due to space constraints, the two clutch assemblies are concentric. To automatically shift from 1st gear to 2nd gear, first the computer detects that the spinning speed of the input shaft is too high, and engages the 2nd gear's collar to the 2nd gear. The clutch then disengages from 1st gear's input shaft, and engages the 2nd gear's input shaft. Controlled by computer, the gear shift becomes extremely fast compared with a conventional manual transmission.

Using direct contact of the clutch instead of fluid coupling also improves power transmission efficiency. Another advanced technology used for direct shift transmission allows it to perform "double clutching" by shifting the gear to neutral first, adjusting the spinning speed of the input shaft, and then shifting to the next gear. This makes gear shifting very smooth.

Operation Modes Of D.S.G.:- "D" mode:

When the motor vehicle is stationary, in neutral, both clutch packs are fully disengaged. When the driver has selected D for drive (after pressing the foot brake pedal), the transmission's first gear is selected on the first shaft, and the clutch prepares to engage. At the same time, the second gear is also selected, but the clutch pack for second gear remains fully disengaged. When the driver releases the brake pedal, the clutch pack for the first gear takes up the drive, and the vehicle moves forward. Pressing the accelerator pedal increases forward speed. As the car accelerates, the transmission's computer determines when the second gear (which is connected to the second clutch) should be fully utilized.

Depending on the vehicle speed and amount of power being requested by the driver (full throttle or part-throttle normal driving), the D.S.G. then up-shifts. During this sequence, the DSG disengages the first clutch while engaging the second clutch (all power from the engine is now going through the second shaft), thus completing the shift sequence. This sequence happens in 8 ms, and there is practically no power loss.

Once the vehicle has shifted up to second gear, the first gear is immediately de-selected, and third gear (being on the same shaft as 1st and 5th) is pre-selected, and is pending. Once the time comes to shift, the second clutch disengages and the first clutch re-engages. This method of operation continues in the same manner up to 6th gear. Downshifting is similar to up-shifting but in reverse order. The car's computer senses the car slowing down or more power required, and thus lines up a lower gear on one of the shafts not in use, and then completes the downshift.

The actual shift timings are determined by the D.S.G.'s Electronic Control Unit, or E.C.U., which commands a hydro-mechanical unit, and the two units combined are called a "mechatronics" unit. Because the D.S.G. & E.C.U. uses "fuzzy logic", the operation of the DSG is said to be "adaptive"; i.e. the DSG will "learn" how the user drives the car, and will tailor the shift points accordingly.

In the vehicle instrument display, between the speedometer and tachometer, the available shift positions are shown, the current position of the shift lever is highlighted, and the current gear ratio is also displayed as a number. Under "normal", progressive acceleration and deceleration, the DSG shifts in a "sequential" mode, i.e. under acceleration: 1 > 2 > 3 > 4 > 5 > 6, and the same sequence reversed for deceleration. However, if the car is being driven at sedate speeds, with a light throttle opening, and the accelerator pedal is then pressed fully to the floor, this activates the "kick-down" function. During kick-down, the DSG can skip gears, going from 6th gear straight down to 3rd gear.

"S" mode:

The floor selector lever also has an S position. When S is selected, "sport" mode is activated in the DSG. Sport mode still functions as a fully automatic mode, identical in operation to "D" mode, but up-shifts and down-shifts are made much higher up the engine rev-range. This aids a sportier driving manner, by utilizing considerably more of the available engine power, and also maximizing engine braking. However, this mode does have a worsening effect on the vehicle fuel consumption, when compared to D mode. S is also highlighted in the instrument display, and like D mode, the currently used gear ratio is displayed as a number.

Manual (Tiptronic) Mode:

Additionally, the floor shift lever also has another plane of operation, for manual or tiptronic mode, with spring-loaded "+" and "-" positions. This plane is selected by moving the stick away from the driver (in vehicles with the drivers seat on the right, the lever is pushed to the left, and in left-hand drive cars, the stick is pushed to the right) when in "D" mode only. When this plane is selected, the D.S.G. can now be controlled like a manual gearbox, even though under a sequential shift pattern.

The readout in the instrument display changes to 6 -5- 4- 3- 2- 1, and just like the automatic modes, the currently used gear ratio is highlighted. To change up a gear, the lever is pushed forwards (against a spring pressure) towards the "+", and to change down, the lever is pulled rearwards towards the "-".

The DSG box can now be operated with the gear changes being (primarily) determined by the driver. This method of operation is commonly called "tiptronic". When accelerating in Manual/tiptronic mode, the D.S.G. will still automatically change up just before the red-line and when decelerating, it will change down automatically at very low revs, just before the engine idle speed (tick over). Furthermore, if the driver calls for a gear when it is not appropriate (i.e., engine speed near the red-line, and a down change is requested) the D.S.G. will delay the change until the engine revs are at an appropriate level to cope with the requested gear.

Paddle Shifters:

On certain "sporty" or high-powered cars paddle shifters are available. The paddle shifters have two distinct advantages: the driver can safely keep both hands on the steering wheel when using the Manual/tiptronic mode; and the driver can immediately manually override either of the automatic programs (D or S) on a temporary basis, and gain instant manual control of the D.S.G. box.

If the manual override of one of the automatic programs (D or S) is utilized intermittently, the gearbox will "default" back to the previously selected automatic mode after a predetermined duration of inactivity of the paddles, or when the car becomes stationary. Alternatively, should the driver wish to revert immediately to automatic control, this can be done by holding the "+" paddle for at least two seconds.

Electro Hydraulic Manual Transmission:

In electro-hydraulic manual transmission (also known as sequential transmission) the gear set is almost the same as the conventional transmission system, except that the shifting of the selector is not an “H” pattern. Instead, all selector forks are connected to a drum. The drum has several grooves, and each has a ball sliding in it. Each fork hooks up to a ball and can be moved forward and backward when the drum is turning. Based on the pattern of the grooves on the drum, by turning the drum, each fork can move forward and backward in turn, which makes gear selection sequential. Therefore, it is impossible for an electro-hydraulic manual transmission to perform a gear shift from 1st to 3rd or 4th to 2nd. The shifting must be sequential, like 1st → 2nd → 3rd → 4th, or 4th → 3rd → 2nd → 1st.

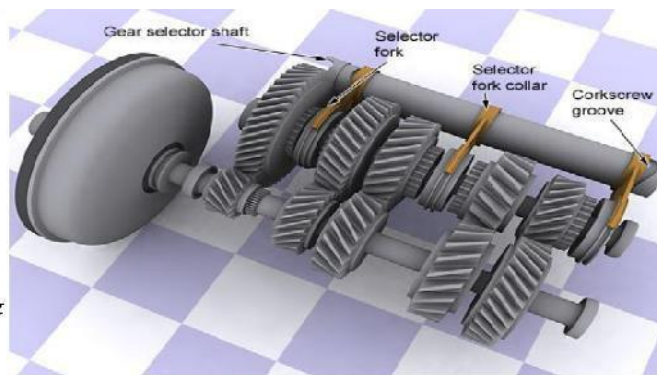
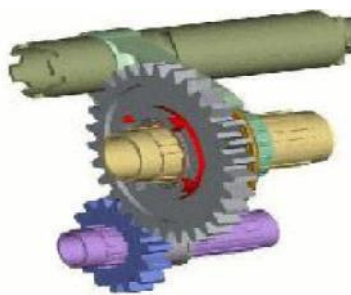
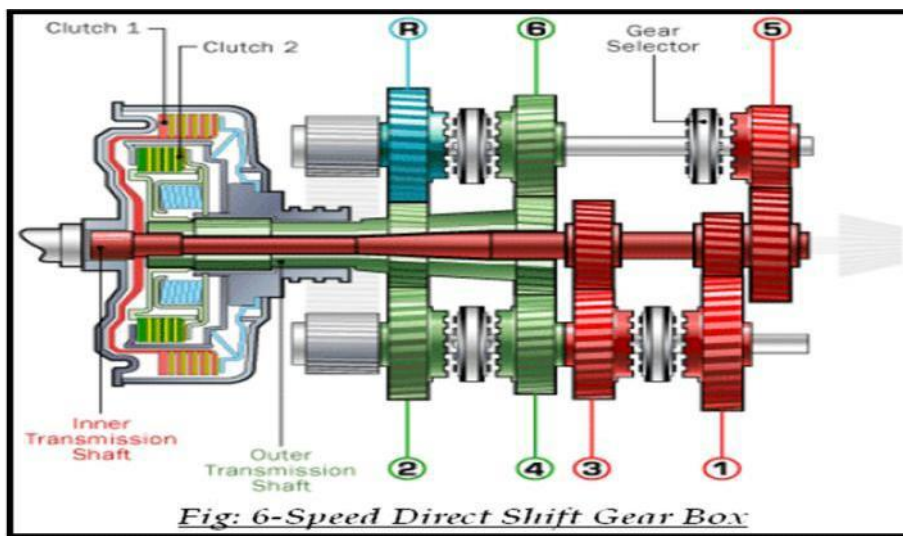

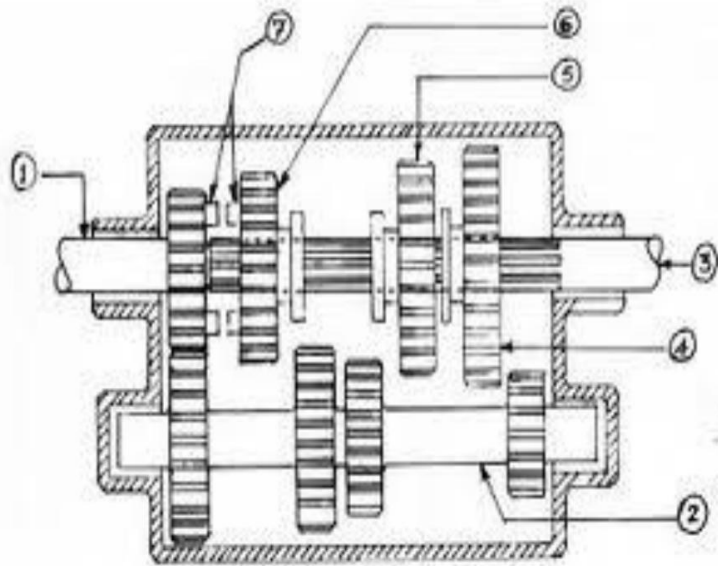
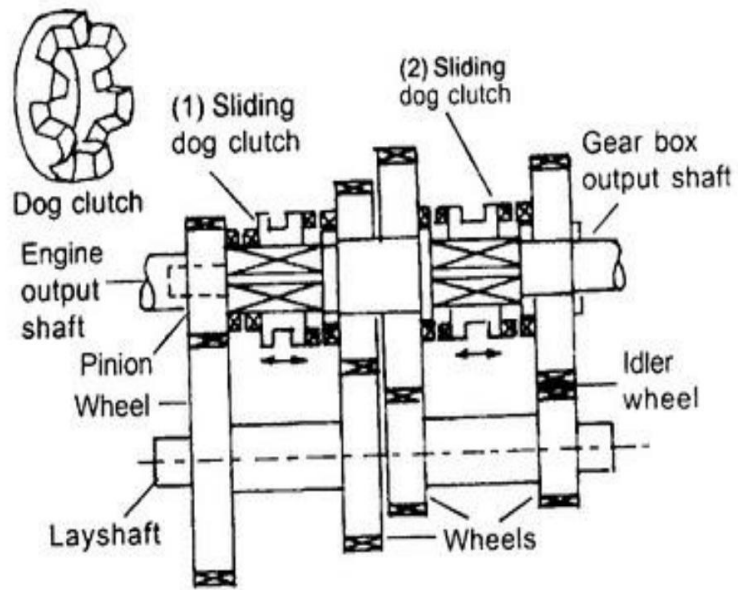

3.10.1. Hotchkiss drive;

The Hotchkiss drive is a system of power transmission. It was the dominant form of power transmission for front-engine, rear-wheel drive layout cars in the 20th century. The name comes from the French automobile firm of Hotchkiss, although it is clear that other makers (such as Peerless) used similar systems before Hotchkiss.

During the early part of the 20th century the two major competing systems of power transmission were the shaft-drive and chain-drive configurations. The Hotchkiss drive is a shaft-drive system (another type of direct-drive transmission system is the torque tube, which was also popular until the 1950s).

All shaft-drive systems consist of a driveshaft (also called a "propeller shaft" or Cardan shaft) extending from the transmission in front to the differential in the rear. The differentiating characteristic of the Hotchkiss drive is the fact that it uses universal joints at *both* ends of the driveshaft, which is not enclosed. The use of two universal joints, properly phased and with parallel alignment of the drive and driven shafts, allows the use of simple cross-type universals. (In a torque-tube arrangement only a single universal is used at the end of the transmission tail shaft, and this universal should be a constant velocity joint.)

In the Hotchkiss drive, slip-splines or a plunge-type (ball and trunnion u-joint) eliminate thrust transmitted back up the driveshaft from the axle, allowing simple rear-axle positioning using parallel leaf springs. (In the torque-tube type this thrust is taken by the torque tube to the transmission and thence to the transmission and motor mounts to the frame. While the torque-tube type requires additional locating elements, such as a Panhard rod, this allows the use of coil springs.)

Some Hotchkiss drive shafts are made in two pieces with another universal joint in the center for greater flexibility, typically in trucks and specialty vehicles built on truck frames. Some installations use rubber mounts to isolate noise and vibration. The 1984–1987 RWD Toyota Corolla (i.e., Corolla SR5 and GT-S) coupe is another example of a car that uses a 2-part Hotchkiss driveshaft with a rubber-mounted center bearing.

This design was the main form of power transmission for most cars from the 1920s through the 1970s. Presently (circa 2012), it remains common in pick-up trucks, and sport utility vehicles.

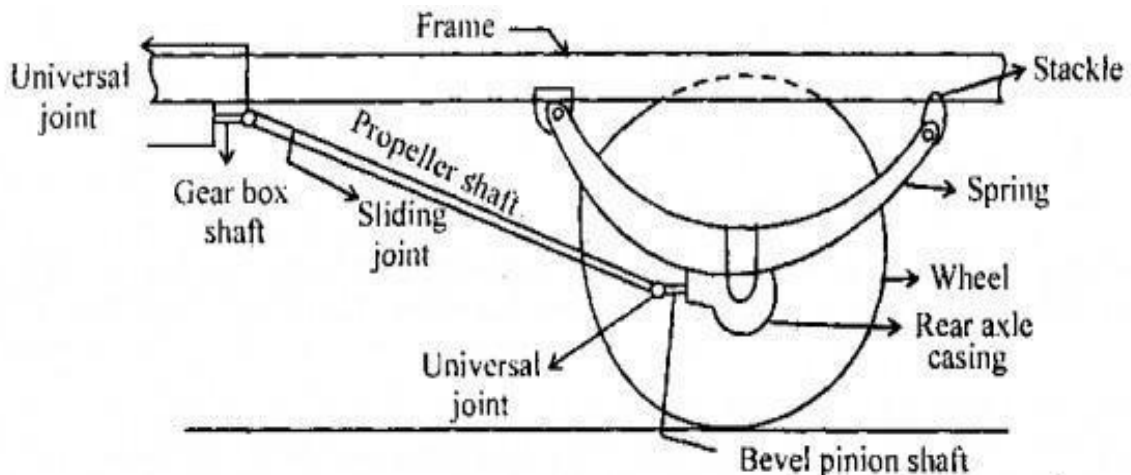

3.10.2. Torque tube Drive

A torque tube system is a driveshaft technology, often used in automobiles with a front engine and rear drive. It is not as widespread as the Hotchkiss drive, but is still occasionally used to this day. Drive shafts are sometimes also used for other vehicles and machinery.

The "torque" that is referred to in the name is not that of the driveshaft, along the axis of the car, but that applied by the wheels. The design problem that the torque tube solves is how to get the traction forces generated by the wheels to the car frame. The "torque tube" transmits this force by directly coupling the axle differential to the transmission and therefore propels the car forward by pushing on the engine/transmission and then through the engine mounts to the car frame

In contrast, the Hotchkiss drive has the traction forces transmitted to the car frame by using other suspension components such as leaf springs or trailing arms. A ball and socket type of joint called a "torque ball" is used at one end of the torque tube to allow relative motion between the axle and transmission due to suspension travel. Since the torque tube does not constrain the axle in the lateral (side-to-side) direction a pan hard rod is often used for this purpose. The combination of the pan hard rod and the torque tube allows the easy implementation of soft coil springs in the rear to give good ride quality.

In addition to transmitting the traction forces, the torque tube is hollow and contains the rotating driveshaft. Inside the hollow torque ball is the universal joint of the driveshaft that allows relative motion between the two ends of the driveshaft. In most applications the drive shaft uses a single universal joint which has the disadvantage that it causes speed fluctuations in the driveshaft when the shaft is not straight. The Hotchkiss drive uses two universal joints which has the effect of canceling the speed fluctuations and gives a constant speed even when the shaft is no longer straight

