

FORMATION OF BUS ADMITTANCE MATRIX OF LARGE POWER NETWORK

In a power system, power is injected into a bus from generators, while the loads are tapped from it. There may be some buses with only generators and there may be other only with loads. Some buses have generators and loads while some other may have static capacitors for reactive power compensation. The surplus power at some of the buses is transported through transmission lines to the bus deficient in power.

Single line diagram of a simple 4-bus system with generators and load at an each bus is shown in the figure. Let S_{Gi} denote the 3-phase complex generator power flowing into the i th bus and S_{Di} denotes the 3-phase complex power demand at the i th bus. Let S_{Gi} and S_{Di} may be represented as

$$S_{Gi} = P_{Gi} + jQ_{Gi}$$

$$S_{Di} = P_{Di} + jQ_{Di}$$

Net complex power injected into the bus is given as

$$S_i = P_i + jQ_i = (P_{Gi} - P_{Di}) + j(Q_{Gi} - Q_{Di})$$

The real and reactive power injected into the i th bus is then.

$$P_i = P_{Gi} - P_{Di}$$

$$Q_i = Q_{Gi} - Q_{Di}$$

where $i = 1, 2, 3, 4, \dots, n$.

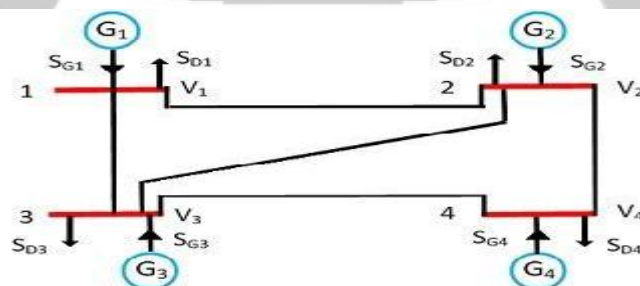

One Line Diagram of a 4-Bus System

A network model of the given power system worked out on the above line is shown below in the figure. S_1, S_2, S_3, S_4 denote the net 3-phase complex power flowing into the buses and I_1, I_2, I_3, I_4 denotes the current flowing into the buses. Each transmission line is represented by a π -circuit.

The equivalent circuit of 4-bus system is shown in the figure below. All the sources of the bus system connected to the common reference at ground potential and the shunt admittance at the busses have been lumped. Besides the ground node, it has four other nodes or buses at which the current from the source is injected into the network. The line admittance between nodes i and k is represented by $y_{ik} = y_{ki}$. Further, the mutual admittance between lines is assumed to be zero.

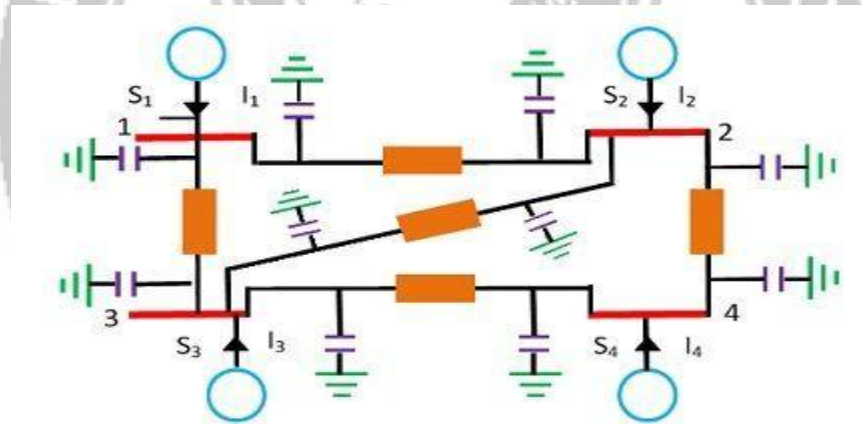

Applications of Kirchhoff's current law to the four nodes give the following equation.

$$I_1 = V_1 y_{10} + (V_1 - V_2) y_{12} + (V_1 - V_3) y_{13}$$

$$I_2 = V_2 y_{20} + (V_2 - V_1) y_{12} + (V_2 - V_3) y_{23} + (V_2 - V_4) y_{24}$$

$$I_3 = V_3 y_{30} + (V_3 - V_1) y_{13} + (V_3 - V_2) y_{23} + (V_3 - V_4) y_{34}$$

$$I_4 = V_4 y_{40} + (V_4 - V_2) y_{24} + (V_4 - V_3) y_{34}$$

The above equation can be rearranged and written in matrix form as below.

$$\begin{bmatrix} I_1 \\ I_2 \\ I_3 \\ I_4 \end{bmatrix} = \begin{bmatrix} y_{10} + y_{12} + y_{13} & -y_{12} & -y_{13} & 0 \\ -y_{12} & y_{20} + y_{12} + y_{23} + y_{24} & -y_{23} & -y_{24} \\ -y_{13} & -y_{23} & y_{30} + y_{13} + y_{23} + y_{34} & -y_{34} \\ 0 & -y_{24} & -y_{34} & y_{40} + y_{24} + y_{34} \end{bmatrix} \begin{bmatrix} V_1 \\ V_2 \\ V_3 \\ V_4 \end{bmatrix}$$

The self-admittance terms of the matrix are given as

$$y_{11} = y_{10} + y_{12} + y_{13}$$

$$y_{22} = y_{20} + y_{12} + y_{23} + y_{24}$$

$$y_{33} = y_{30} + y_{13} + y_{23} + y_{34}$$

$$y_{44} = y_{40} + y_{24} + y_{34}$$

The mutual admittances of the matrix are given as

$$y_{12} = y_{21} = -y_{12} \quad y_{23} = y_{32} = -y_{23}$$

$$y_{13} = y_{31} = -y_{13} \quad y_{24} = y_{42} = -y_{24}$$

$$y_{14} = y_{41} = -y_{14} = 0 \quad y_{34} = y_{43} = -y_{34}$$

Matrix is written in terms of self-bus admittance Y_i and mutual bus admittance Y_{ik} as follows.

$$\begin{bmatrix} I_1 \\ I_2 \\ I_3 \\ I_4 \end{bmatrix} = \begin{bmatrix} y_{11} & y_{12} & y_{13} & y_{14} \\ y_{21} & y_{22} & y_{23} & y_{24} \\ y_{31} & y_{32} & y_{33} & y_{34} \\ y_{41} & y_{42} & -y_{43} & y_{44} \end{bmatrix} \begin{bmatrix} V_1 \\ V_2 \\ V_3 \\ V_4 \end{bmatrix}$$

Y_{ii} is known as self-admittance (or driving point admittance) of the i_{th} node and is equal to the sum of the admittance connected to the i_{th} node. Each off-diagonal term Y_{ik} is known as mutual admittance (or transfer admittance) between i_{th} and k_{th} node and is equal to the negative of the sum of all the admittances connected directly between i_{th} and k_{th} node

The equation can be written in compact form as

$$[I_{bus}] = [Y_{bus}][V]$$

Where I is the current node matrix, V is the node voltage matrix and [Ybus] is the bus admittance matrix. General equation for n-bus network based on Kirchoff's' current law and admittance form is

$$[I_{bus}] = [Y_{bus}] * [V]$$

Where [I] is the n-bus matrix, [V] is the n-bus voltage matrix and, [Ybus] is called bus admittance matrix and is written as

$$I = Y_{bus}V$$

$$Y_{bus} = \begin{bmatrix} Y_{11} & Y_{12} & - & Y_{1n} \\ Y_{21} & Y_{22} & - & Y_{2n} \\ - & - & - & - \\ Y_{n1} & Y_{n2} & - & y_{nn} \end{bmatrix}$$

it is called the bus admittance matrix and V and I are the n-element node voltage matrix and current node matrix respectively.