

3.5 Switched Mode Regulators -BUCK REGULATOR

Switched Mode Regulators provide much greater power efficiency in DC-to-DC conversion than linear regulators, which are simpler circuits that lower voltages by dissipating power as heat, but do not step up output current. Switched mode regulators consists of energy storage elements along with dc-dc chopper circuits. To reduce voltage ripple, filters made of capacitors (or capacitors in combination with inductors) are normally added to such a converter's output (load-side filter) and input (supply-side filter).

Switched Mode Regulators are classified into Buck, Boost, Buck-Boost Regulators.

BUCK REGULATOR

A buck converter (step-down converter) is a DC-to-DC power converter which steps down voltage while stepping up current from its input (supply) to its output (load).

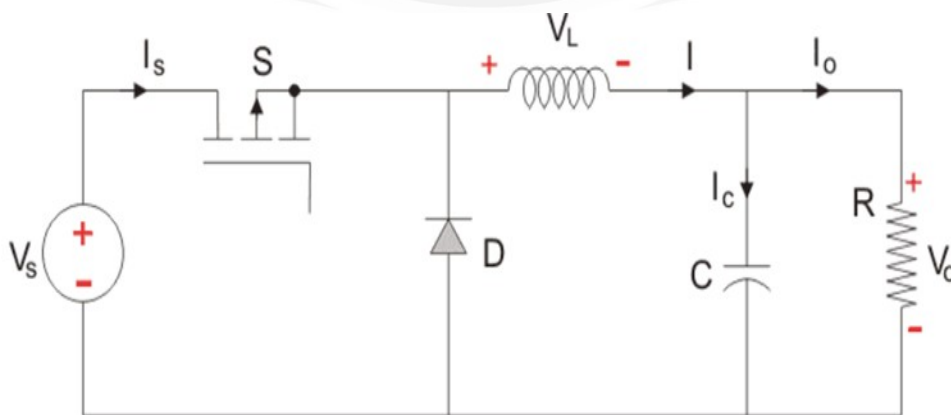

Figure 3.5.1 BUCK REGULATOR

[Source: "Power Electronics" by P.S.Bimbra, Khanna Publishers Page: 492]

MODE I: SWITCH IS ON, DIODE IS OFF

The voltage across the capacitance in steady state is equal to the output voltage. The switch is on for a time T_{ON} and is off for a time T_{OFF} . We define the time period, T , as $T=T_{on}+T_{off}$, and the switching frequency,

$$f = 1/T = \text{chopping frequency}$$

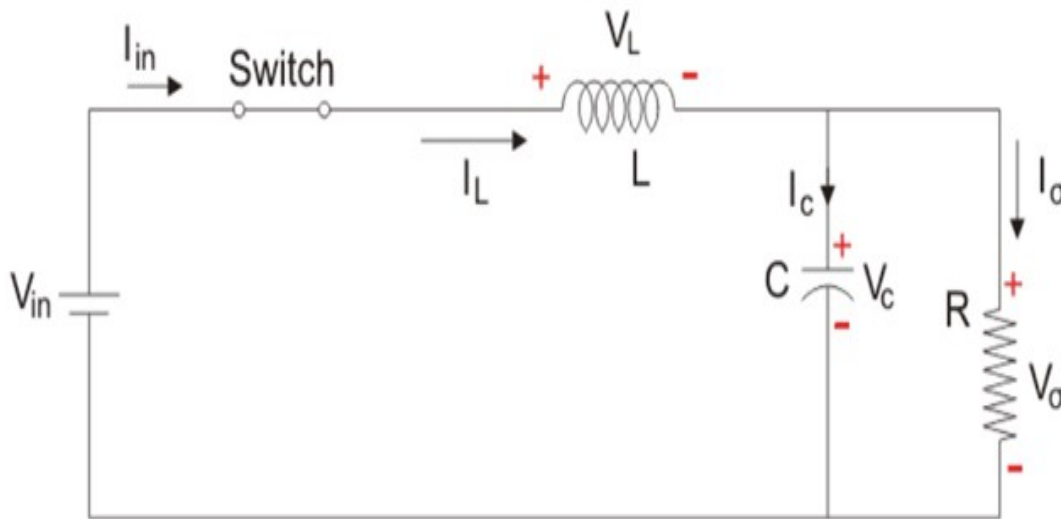

Figure 3.5.2 Buck converter- Mode II circuit diagram

[Source: "Power Electronics" by P.S.Bimbira, Khanna Publishers Page: 492]

MODE II: SWITCH IS OFF, DIODE IS ON

Here, the energy stored in the inductor is released and is ultimately dissipated in the load resistance, and this helps to maintain the flow of current through the load. But for analysis we keep the original conventions to analyse the circuit using KVL.

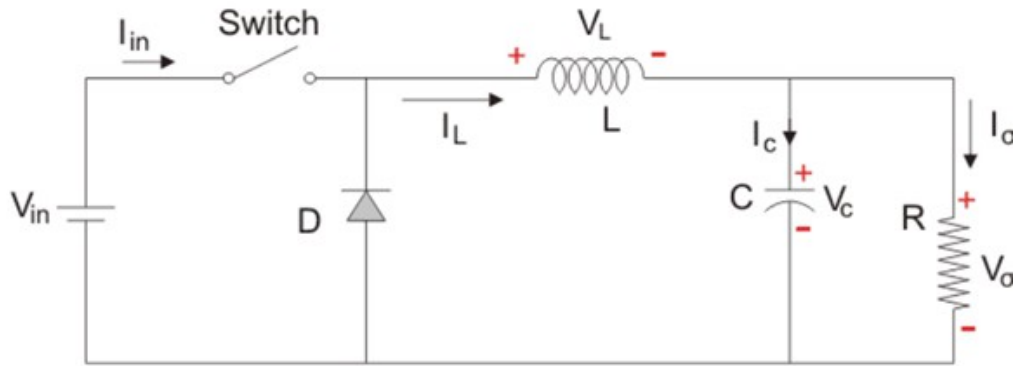

Figure 3.5.3 Buck converter- Mode II circuit diagram

[Source: "Power Electronics" by P.S.Bimbra, Khanna Publishers Page: 493]

Average load Voltage is given by

- ✿ $V_0 = T_{on} / (T_{on} + T_{off}) * V_s = (T_{on}/T) V = D V_s$

- ✿ T_{on} : on -time T_{off} : off- time

- ✿ Thus the load voltage can be controlled by varying the duty cycle D

$$V_0 = f \cdot T_{on} \cdot V_s$$

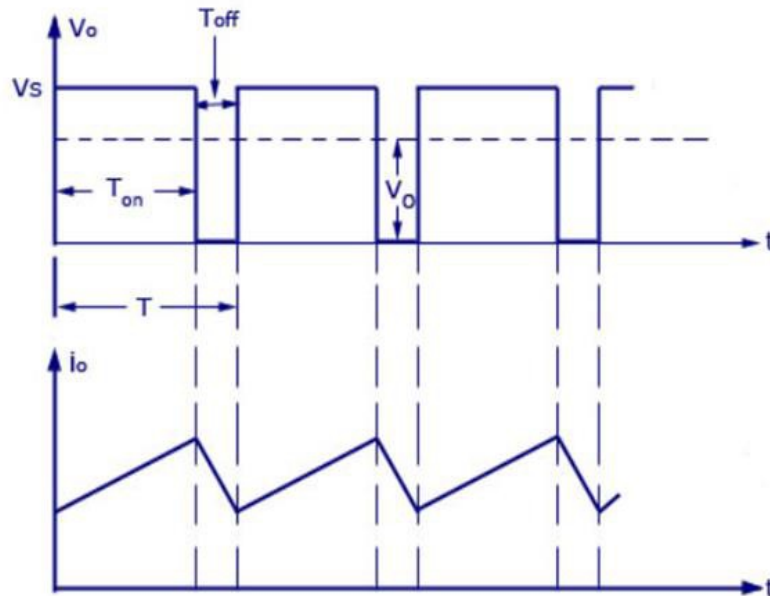

Figure 3.5.4 Buck converter Output Voltage and Current Waveforms

[Source: "Power Electronics" by P.S.Bimbra, Khanna Publishers Page: 493]