

## EXTERNAL MEMORY INTERFACE

### EXTERNAL ROM (PROGRAM MEMORY) INTERFACING

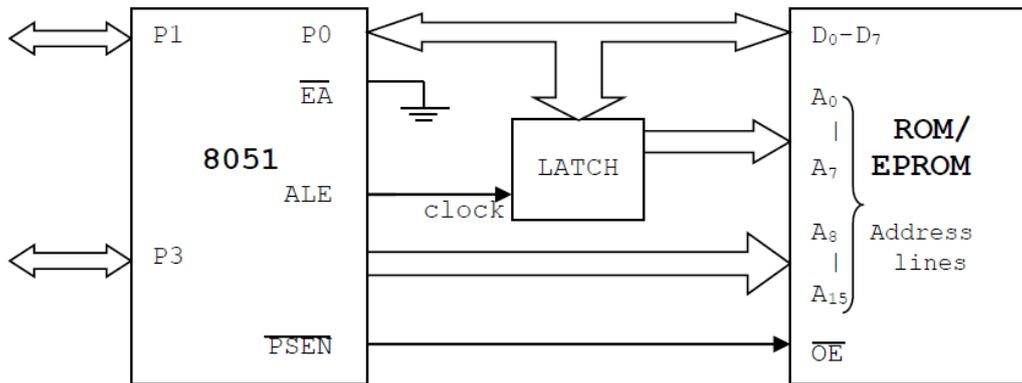

**Figure 5.6.1 Interfacing of ROM/EPROM to 8051**

[Source: “The 8051Microcontroller and Embedded Systems: Using Assembly and C” by Mohamed Ali Mazidi, Janice Gillispie Mazidi, Rolin McKinlay]

Figure 5.6.1 shows how to access or interface ROM to 8051.

- Port 0 is used as multiplexed data & address lines. It gives lower order (A7-A0) 8 bit address in initial T cycle & higher order (A8-A15) used as data bus.
- 8 bit address is latched using external latch & ALE signal from 8051.
- Port 2 provides higher order (A15-A8) 8 bit address.
- PSEN is used to activate the output enable signal of external ROM/EPROM.

### EXTERNAL RAM (DATA MEMORY) INTERFACING

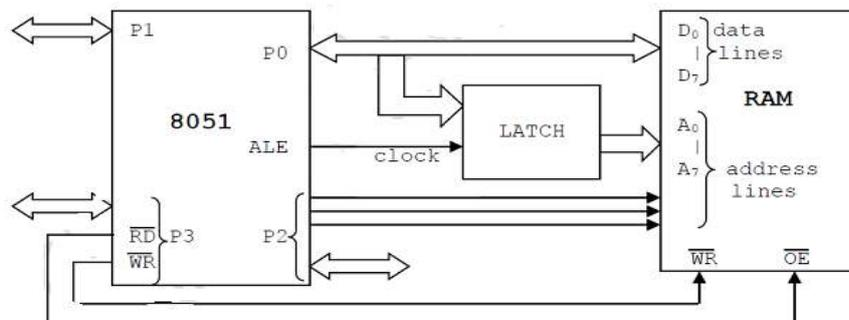

**Figure 5.6.2 Interfacing of RAM to 8051**

[Source: “The 8051Microcontroller and Embedded Systems: Using Assembly and C” by Mohamed Ali Mazidi, Janice Gillispie Mazidi, Rolin McKinlay]

Figure 5.6.2 shows how to connect or interface external RAM (data memory) to 8051.

- Port 0 is used as multiplexed data & address lines.
- Address lines are decoded using external latch & ALE signal from 8051 to provide lower order (A7-A0) address lines.
- Port 2 gives higher order address lines.
- RD & WR signals from 8051 selects the memory read & memory write operations respectively.

**Note:**RD & WR signals: generally P3.6 & P3.7 pins of port 3 are used to generate memory read and memory write signals. Remaining pins of port 3 i.e. P3.0-P3.5 can be used for other functions.

### Solved Examples:

**Example 1:** Design a  $\mu$ Controller system using 8051 to Interface the external RAM of size 16k x 8.

**Solution:** Given, Memory size: 16k

Which means, we require  $2^n=16k$ : n address lines

- Here n=14: A0 to A13 address lines are required.
- A14 and A15 are connected through OR gate to CS pin of external RAM.
- When A14 and A15 both are low (logic '0'), external data memory (RAM) is selected.

### Address Decoding (Memory Map) For 16k X 8 Ram

Addr ess	A15	A14	A13	A12	A11	A10	A9	A8	A7	A6	A5	A4	A3	A2	A1	A0	Hex Addr
Start	0	0	0	0	0	0	0	0	0	0	0	0	0	0	0	0	0000 H
End	0	0	1	1	1	1	1	1	1	1	1	1	1	1	1	1	3FF FH

Figure 5.6.3 shows interfacing of 16k x 8 RAM to 8051.

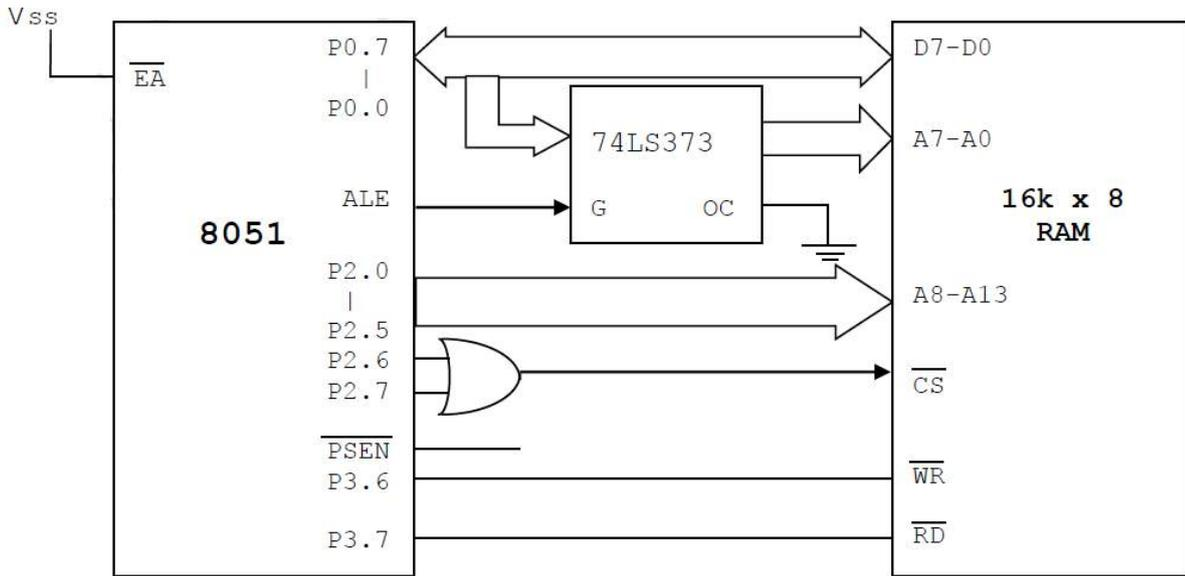

**Figure 5.6.3 16Kx8 Memory (RAM) Interfacing with 8051**

[Source: “The 8051Microcontroller and Embedded Systems: Using Assembly and C” by Mohamed Ali Mazidi, Janice Gillispie Mazidi, Rolin McKinlay]

**Example 2:** Design a  $\mu$ Controller system using 8051 to interface the external ROM of size 4k x 8.

**Solution:** Given, Memory size: 4k

i.e we require  $2^n=4k :: n$  address lines

- Here  $n=12 :: A0$  to  $A11$  address lines are required.
- Remaining lines  $A0, A0, A0, A0$  & PSEN are connected though OR gate to CS & RD of external ROM.
- When  $A0$  to  $A0$  are low (logic ‘0’), only then external ROM is selected.

**Address Decoding (Memory Map)for 4k x 8 RAM**

Addr ess	A1 5	A1 4	A1 3	A1 2	A1 1	A1 0	A 9	A 8	A 7	A 6	A 5	A 4	A 3	A 2	A 1	A 0	Hex Addr
Start	0	0	0	0	0	0	0	0	0	0	0	0	0	0	0	0	0000 H
End	0	0	0	0	1	1	1	1	1	1	1	1	1	1	1	1	0FF FH

Figure 5.6.4 shows interfacing of 4k x 8 ROM to 8051

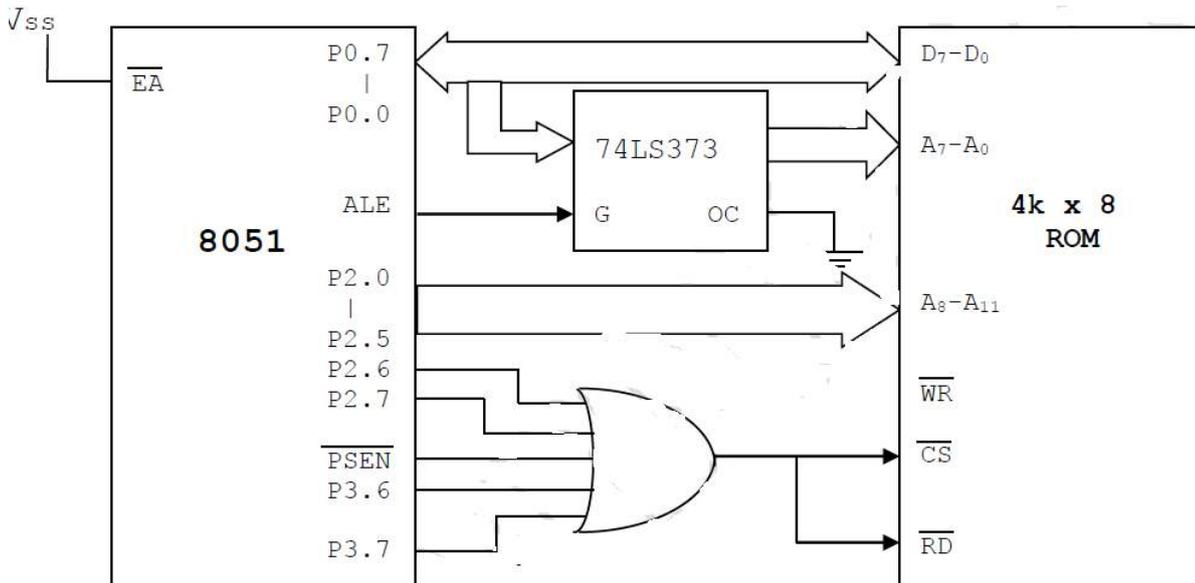

**Figure 5.6.4 4Kx8 Memory (ROM) Interfacing with 8051**

[Source: "The 8051 Microcontroller and Embedded Systems: Using Assembly and C" by Mohamed Ali Mazidi, Janice Gillispie Mazidi, Rolin McKinlay, pg.no.320]

**Example 3:** Design a  $\mu$ Controller system using 8051, 16k bytes of ROM & 32k bytes of RAM. Interface the memory such that starting address for ROM is 0000H & RAM is 8000H.

**Solution:**

Given, Memory size- ROM : 16k

i.e we require  $2^n=16k :: n$  address lines

Here  $n=14 :: A_0$  to  $A_{13}$  address lines are required.

$A_{14}, A_{15}, PSEN$  ORed CS when low – ROM is selected

Memory size- RAM : 32k

i.e we require  $2^n=32k :: n$  address lines

Here  $n=15 :: A_0$  to  $A_{15}$  address lines are required.

$A_{15}$  inverted (NOT Gate) CS when high- RAM is selected.

For RAM selection

- PSEN is used as chip select pin ROM.
- RD is used as read control signal pin..
- WR is used as write control signal pin.

**Address Decoding (Memory Map) for 16k x 8 ROM.**

Addr ess	A15	A14	A13	A12	A11	A10	A9	A8	A7	A6	A5	A4	A3	A2	A1	A0	Hex Addr
Start	0	0	0	0	0	0	0	0	0	0	0	0	0	0	0	0	0000 H
End	0	0	1	1	1	1	1	1	1	1	1	1	1	1	1	1	3FF FH

**Address Decoding (Memory Map) for 32k x 8 RAM.**

Addr ess	A15	A14	A13	A12	A11	A10	A9	A8	A7	A6	A5	A4	A3	A2	A1	A0	Hex Addr
Start	1	0	0	0	0	0	0	0	0	0	0	0	0	0	0	0	8000 H
End	1	1	1	1	1	1	1	1	1	1	1	1	1	1	1	1	FFF FH

Figure 5.6.5 shows the interfacing of 16Kx8 Memory (ROM) and 32Kx8 RAM with 8051

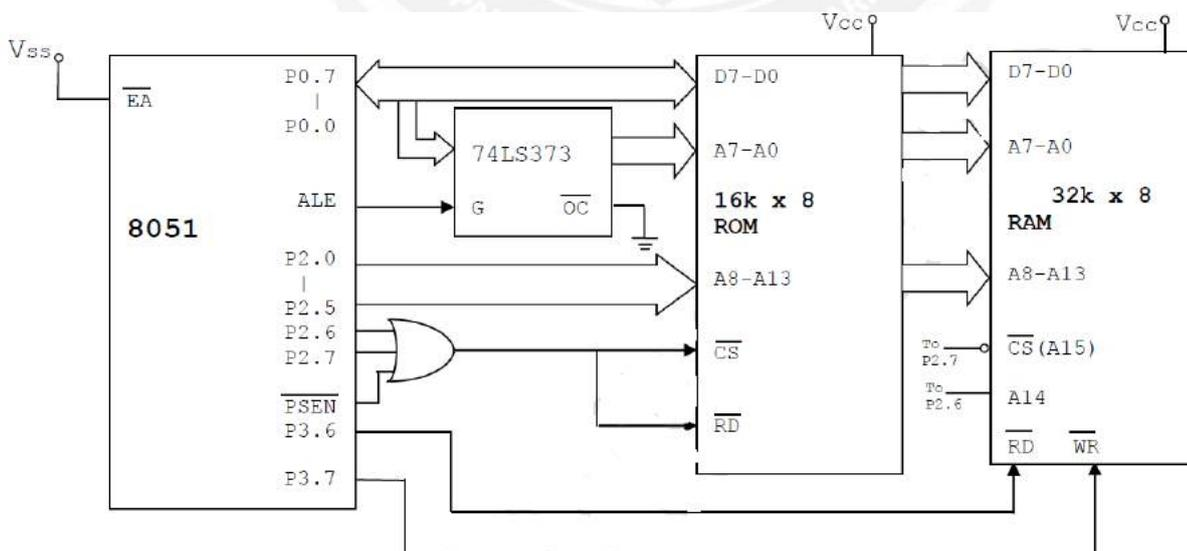

**Figure 5.6.5 16Kx8 Memory (ROM) and 32Kx8 RAM Interfacing with 8051**

[Source: "The 8051 Microcontroller and Embedded Systems: Using Assembly and C" by Mohamed Ali Mazidi, Janice Gillispie Mazidi, Rolin McKinlay, pg.no.320]