

Single Line Diagram of Power System

Single line diagram is the representation of a power system using the simple symbol for each component. The single line diagram of a power system is the network which shows the main connections and arrangement of the system components along with their data (such as output rating, voltage, resistance and reactance, etc.).

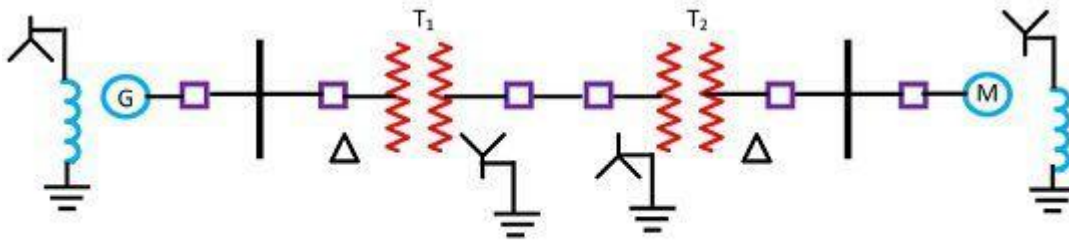

Single Line Representation of a Typical Power System

Circuit Globe

Circuit breakers are represented by rectangular blocks. It is difficult to draw the line diagram of the few components. So for simplification, the impedance diagram is used for representing the power system components.

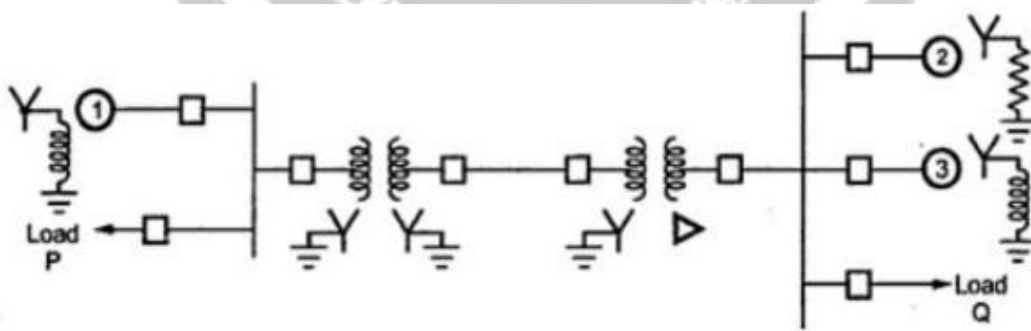

Single Line diagram of an Electrical system



Two generators one grounded through a reactor and one through a resistor connected to a bus and through a step up transformer to a transmission lines. Another generator grounded a reactor is connected a bus and through a transformer to the opposite end of the transmission line.A load is connected to

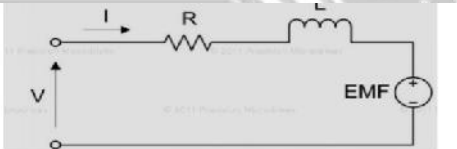
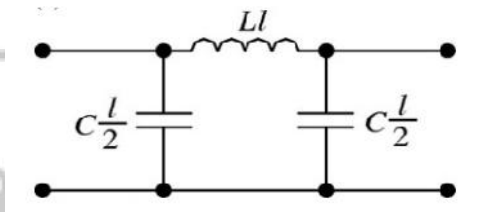
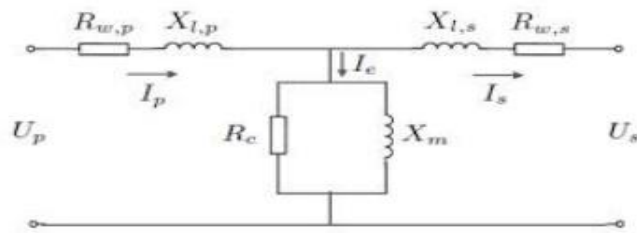

each bus. On the diagram information about the loads the ratings of the generators and transformers and reactance of different components of the circuit is often given. It is important to know the location of points where a system is connected to ground to calculate the amount of current flowing when an unsymmetrical fault involving ground occur.

Equivalent circuit for various power system components:

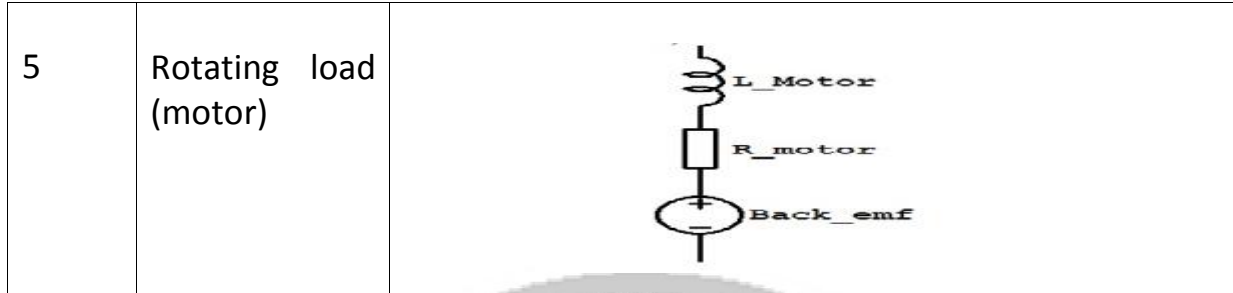
S.No	Component	Equivalent circuit
1	Generators	
2	Transmission lines	
3	Transformer	
4	Static load	

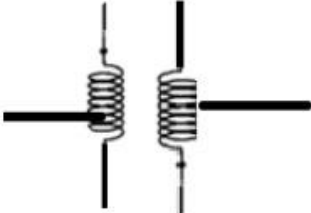

REPRESENTATION OF COMPONENTS AND SYMBOL

Sl.no	Components	Symbol
1	Rotating M/c(or) armature	
2	Bus	
3	Two winding power Transformer	
4	Three winding power Transformer	